

# *Self-Propelled* **CONCRETE / ASPHALT SAW**

## SS-16 & SS-18

### OPERATORS MANUAL

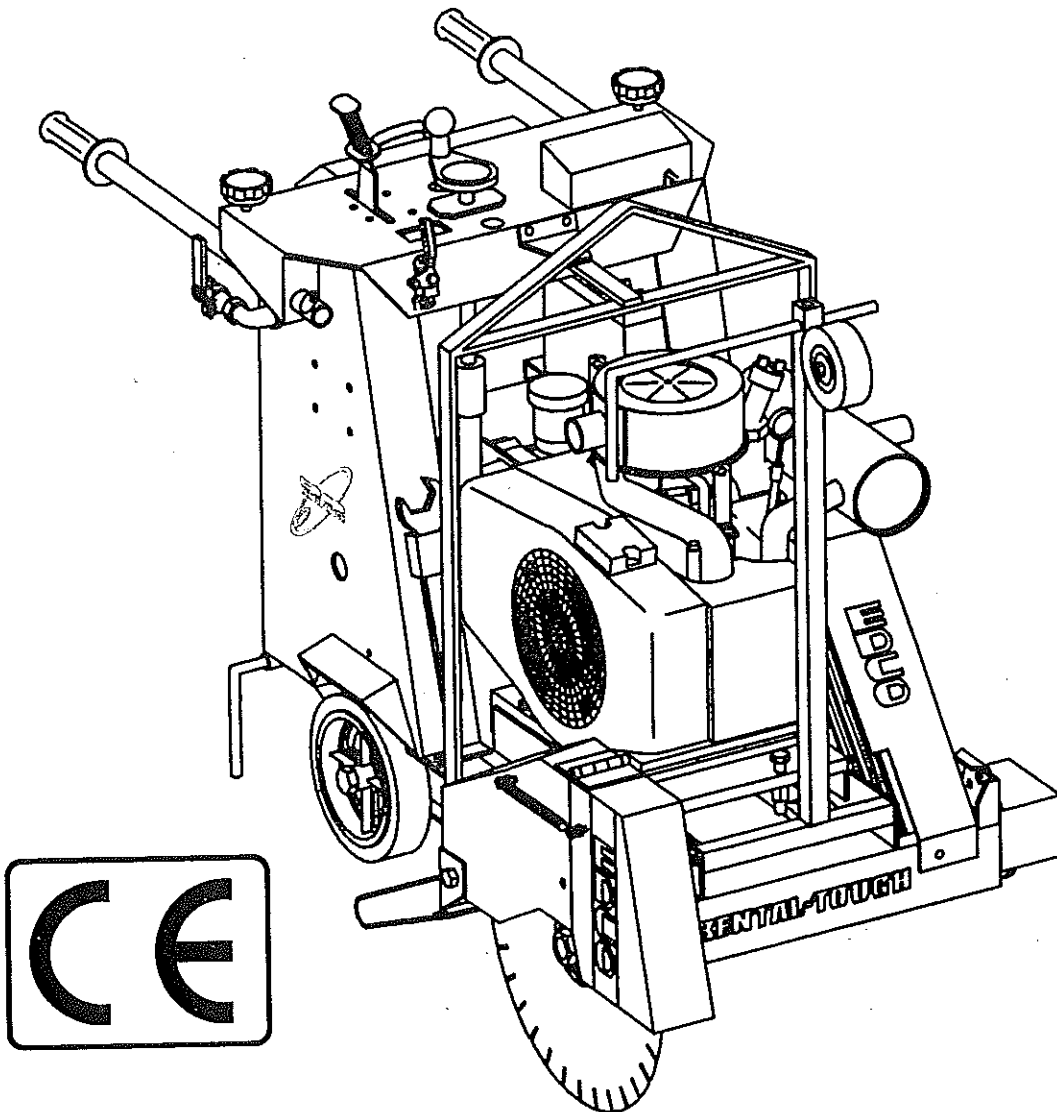

*Quality Built In The U.S.A.!*

Printed in USA

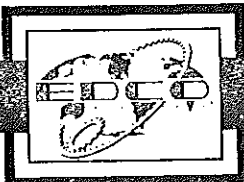

**EQUIPMENT DEVELOPMENT COMPANY, INC.**

100 THOMAS JOHNSON DRIVE, FREDERICK, MD 21702-4600 USA  
Phone (301) 663-1600 Toll Free 1-800-638-3326 Fax (301) 663-1607 Fax Free 1-800-447-3326

©1997

**READ AND UNDERSTAND THESE INSTRUCTIONS THOROUGHLY  
BEFORE ATTEMPTING TO OPERATE THIS EQUIPMENT.**

Death or serious injury could occur if the machine is used improperly.

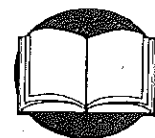
**SAFETY MESSAGES**

The safety instructions are preceded by a graphic alert message of DANGER, WARNING or CAUTION.



A safety instruction that advises that death or serious injury will result if instructions are not followed and caution exercised.



A safety instruction that advises that death or serious injury can result if instructions are not followed and caution exercised.



A safety instruction that advises that injury could result if instructions are not followed.

**GASOLINE POWERED EQUIPMENT**

The engine exhaust from this product contains chemicals known, in certain quantities, to cause cancer, birth defects or other reproductive harm.



Do not operate gasoline powered equipment without adequate ventilation. Carbon monoxide is an invisible, odorless gas that can kill.

**ELECTRIC POWERED EQUIPMENT**

ELECTRICAL HAZARD - Be sure equipment is properly grounded. Failure to comply could kill or result in serious injury.

**PLEASE FILL IN INFORMATION AND SAVE**

Date of Purchase \_\_\_\_\_

Name of Machine \_\_\_\_\_

Model # \_\_\_\_\_

Serial # \_\_\_\_\_

Belt Size(s) \_\_\_\_\_

**WARNING**

The engine exhaust from this product contains chemicals known to the State of California to cause cancer, birth defects or other reproductive harm.

This equipment will create dust from the material being removed. That dust may contain a chemical known to the State of California to cause cancer and/or birth defects or other reproductive harm. As an example, paints and concrete contain chemicals known to the State of California to cause cancer and/or birth defects or other reproductive harm. Check the chemical properties of the material to be removed and take appropriate precautions.

It is the operator's responsibility to keep other people (workers, pedestrians, bystanders, etc.) away during operation. Block off the work area in all directions with roping, safety netting, etc. for a safe distance. Failure to do so may result in others being injured by flying debris or exposing them to harmful dust and noise.

This saw was designed for use with steel core diamond blades only. The operator assumes full responsibility for using any other type of blade. EDCO does NOT recommend the use of abrasive blades.

**GENERAL INSTRUCTIONS**

- Read and understand the instructions, including the engine manual. Different models may have different parts and controls.
- Equipment should only be operated by trained personnel in good physical condition and mental health (not fatigued). The operator and maintenance personnel must be physically able to handle the bulk weight and power of this equipment.
- This is a one person tool. Maintain a safe operating distance to other personnel.
- This equipment is intended for commercial use.
- For the operators safety and the safety of others, always keep all guards in place during operation.
- Keep body parts and loose clothing away from moving parts. Failure to do so could result in dismemberment or death.
- Never let equipment run unattended.
- Do not lend or rent this equipment without including the operation instructions for the machine and the engine.
- Wear proper safety attire when operating this machinery. The operator must wear approved safety equipment appropriate for the job, such as a hard hat, safety shoes, hearing protection, non-fogging vented safety goggles or face mask, and back support. Wear an approved dust/particle respirator when removing hazardous material.
- Do not modify the machine. Use only genuine EDCO parts and accessories. Repairs and service should be performed by approved EDCO dealers or repair technicians.
- Stop engine/motor when adjusting, servicing or fueling.
- Gasoline is extremely flammable and poisonous. It should only be dispensed in well ventilated areas, and with a cool engine.





## SS-16/18 SAFETY INSTRUCTIONS

Read and understand these instructions completely before starting or using machine.



### MACHINE PRECAUTIONS

1. Wear appropriate clothing, footwear, and safety attire when operating this machinery. Do not wear loose clothing that can get tangled in moving parts. Steel toe safety shoes, padded gloves and safety glasses should be worn.

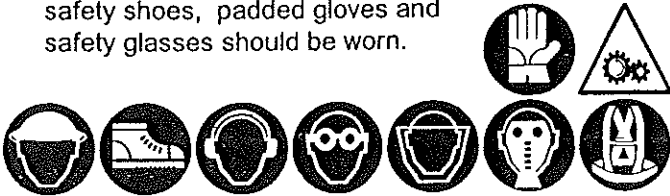

2. Eye and ear protection must be worn at all times when the machine is in use. During normal operation, sound levels exceed 92 dB(A).
3. Wear an approved dust/particle respirator when removing hazardous material or when sawing dry.
4. Maintain a safe operating distance to other personnel.
5. Maintain a safe operating distance from flammable materials. Sparks from the cutting-action of this saw can ignite flammable materials or vapors.
6. Obtain the engine manual. Read it and understand it before continuing. Follow the engine manual for break-in instructions.
7. This concrete / asphalt saw is designed to cut flat, horizontal concrete or asphalt slabs using diamond saw blades. It is controlled by a single operator from a position at the rear of the saw.
8. Read and follow all safety labels.
9. Avoid deck inserts, pipes, columns, openings, electrical outlets, or any objects protruding from slab surface.
10. Stay alert; use common sense, and avoid unsafe conditions.

### OWNER RESPONSIBILITIES:

1. Provide all instruction manuals for the operator to fully read and understand.
2. Provide proper training and instruction to the operator.
3. Maintain safety decals on the machine.
4. Maintain the machine in safe operating condition with all guards securely in place, all mechanical fasteners tight, all controls in working order, and the saw configured for the job application.
5. Maintain a copy of the saw operators manual and engine manual with the machine for reference at all times.
6. Never allow anyone to operate the saw in an impaired physical or mental state.

### OPERATOR RESPONSIBILITIES:

1. Be familiar with all aspects of the machine's operation and controls before starting the engine/motor.
2. Use the correct blade for the job including rated RPM, diameter and proper mounting size configuration.
3. Never operate the saw while under the influence of drugs or alcohol, while taking medications that impair the senses or reactions, or when excessively tired or under stress.
4. Follow the instructions in the operators manual and exercise caution.
5. Never leave the machine running unattended.
6. Comply with local safety and health regulations such as ANSI B7.1 and OSHA regulations.

### Specifications

WEIGHT (approximate — may vary depending on options)

SS-16 .....	460 lbs (209 kg)
SS-18 .....	475 lbs (216 kg)

BLADE DIAMETER (maximum)

SS-16 .....	16 in. (40.64 cm)
SS-18 .....	18 in. (45.72 cm)

ARBOR SHAFT

SS-16 & SS-18.....	1 in. diameter (2.54 cm)
--------------------	--------------------------

ARBOR SPEED (maximum)

SS-16 .....	3600 RPM
SS-18 .....	2800 RPM

### Maintenance Schedule

*Follow Engine Manual Maintenance Schedule*

After First 4 Hours:

- Tension Belts

As Required Thereafter:

- Tension Belts

Before Operation:

- Visually Inspect entire machine
- Check engine oil
- Inspect drive belts
- Inspect blade
- Inspect arbor shaft
- Inspect drive chains

Every 4 Hours:

- Grease Bearings

Daily:

- Clean & oil the air filter (If engine intake shows signs that dust has passed through the air filter, change engine oil.)
- Clean dust & dirt off machine

Weekly:

- Lubricate Drive Chains

Every 50 Hours of Operation:

- Check transmission level
- Change engine oil & filter (sooner if necessary)



## OPERATING INSTRUCTIONS

Read and understand these instructions completely  
before starting or using machine.



### NOTICE

READ "Rx FOR CONCRETE SAWS" SAFETY INSTRUCTIONS BEFORE OPERATING

### NOTICE

1. When loading or unloading the saw from or onto a trailer, on ramp or incline, use extreme caution and low speed. Blade must be raised high enough to clear all obstacles.
2. This unit is shipped with oil but without gasoline. Check engine manual and follow manufacturers instructions on break-in, servicing and use of engine.
3. To "free wheel" - move Clutch Cam Lever (10) to the "DISENGAGED" position. This will release the drive mechanism and the wheels will roll freely.
4. Before starting - check to be sure that blade is raised - not in contact with slab surface and blade guards are in place. Be sure you have selected the proper blade for the job and installed it properly on the arbor shaft.
5. Front and rear guides are adjustable - align saw on cutting line, adjust both front and rear guides. Be sure cutting line is well defined for operator to follow easily.
6. Allow engine to warm up at half throttle before starting to cut.
7. Cut at FULL throttle. DO NOT attempt to change governor setting - it is factory set for correct speed.
8. This saw is designed to cut in a straight line. DO NOT FORCE the saw or twist it back in line.

#### ENGINE STARTING:

- BEFORE starting engine - read instructions supplied by engine manufacturer.
- CHECK OIL LEVEL.
- Be sure blade is clear of slab surface - move Clutch Cam Lever (10) to "Disengaged" position.
- Familiarize yourself with all engine and saw controls. (See Figure 1)

#### MODELS WITHOUT ELECTRIC START ENGINES:

- Locate engine controls: Throttle, Choke, Stop Button
- Locate saw controls: Blade Lift Controls, Water Safety Switch, Drive Selector Lever . . .
- Place Water Safety Switch (6) in the "ENGINE START-DRY CUT" position or engine will not start.
- Change position of the engine-mounted STOP switch to ON (if applicable; check engine manual).
- Follow engine manufacturers instructions on proper starting.
- Open throttle  $\frac{1}{4}$  to  $\frac{1}{2}$  . . . allow engine to reach operating temperature . . .
- NOTE: ALL CUTTING IS DONE AT FULL THROTTLE.

#### MODELS WITH ELECTRIC START:

- Locate engine controls: Throttle, Choke, Ignition ON/OFF Switch
- Locate saw controls: Blade Lift Controls, Water Safety Switch, Drive Selector Lever . . .
- Place Water Safety Switch (6) in the "ENGINE START-DRY CUT" position or engine will not start.
- Follow engine manufacturers instructions on proper starting.
- Momentarily change position of the Engine Ignition Switch (5) to START. After engine starts, leave Engine Ignition Switch in the ON position.
- Open throttle  $\frac{1}{4}$  to  $\frac{1}{2}$  . . . allow engine to reach operating temperature . . .
- NOTE: ALL CUTTING IS DONE AT FULL THROTTLE.

FIGURE #1

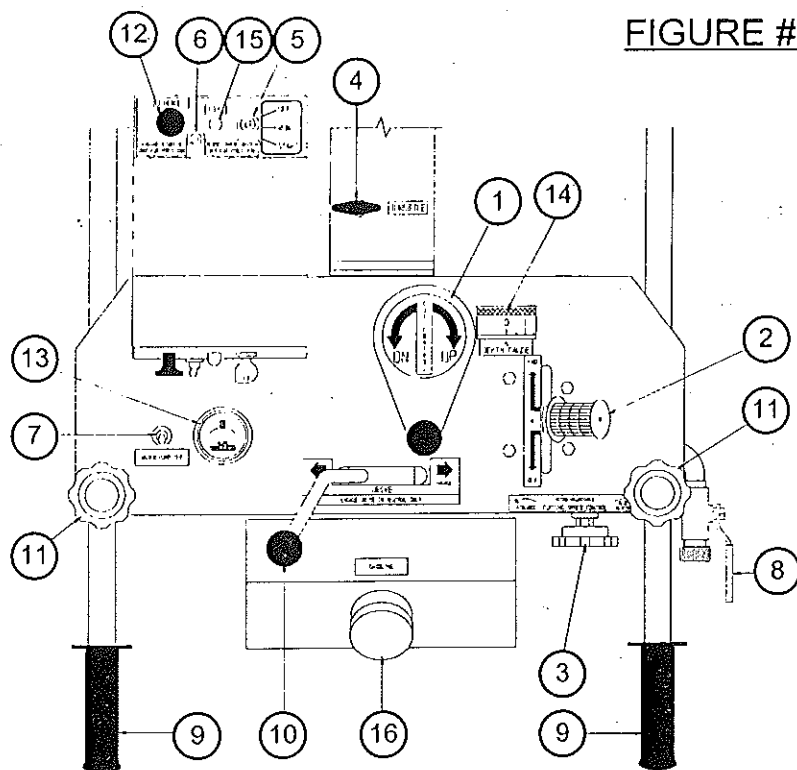

- 1 .....Depth Control Hand Crank
- 2 .....Drive Selector Lever
- 3 .....Speed Control Knob
- 4 .....Throttle
- 5 .....Stop or Ignition ON/OFF Switch
- 6 .....Water Flow - Blade Saver Switch
- 7 .....Electric Water Pump Switch (Optional)
- 8 .....Water Hose Connection - Valve
- 9 .....Handles (Adjustable)
- 10 .....Clutch Cam Lever
- 11 .....Adjustable Handle Position Lock
- 12 .....Choke Cable Knob
- 13 .....Hour Meter -or- Amp. Meter (Optional)
- 14 .....Depth Indicator Gauge (Optional)
- 15 .....Oil Alert Light (Optional)
- 16 .....Gasoline Fill Cap (Model SS-18)

#### WATER FLOW - BLADE SAVER SWITCH OPERATION

1. On all models, the "Water Safety Switch" must be in "START-DRY CUT" position or the engine will not start.
2. The purpose of the Water Safety Switch is to STOP engine if water pressure drops.
3. NOTE: Water Safety Switch detects pressure and cannot detect a clogged line between supply and coolant outlet in blade guard . . . check to be sure water flows freely and is not obstructed.
4. When cutting DRY, leave switch in START-DRY CUT position.
5. When cutting WET, attach supply hose to Water Hose Connection Valve.
6. NOTE: For units with the optional water pump, water flows through the pump assembly at all times.
7. If pressure from outside source, such as city water supply is adequate (2 ½ to 5 gallons per minute) optional water pump need not be engaged.
8. With water flowing through the system freely, and engine running, change position of the Water Safety Switch to the WET CUT position. You have now activated the water control system.
9. Should the engine stop at this point, there is probably not enough water flowing through the blade cooling outlet. Check supply source:
  - a. Is city water valve open full?
  - b. Is valve on saw console open?
  - c. If you are using gravity feed, check the flow.
  - d. After fixing the water supply problem, return the Water Safety Switch to START-DRY CUT position.
  - e. Restart engine, following directions in the ENGINE STARTING section.
  - f. For saws with the optional water pump: engage the water pump; turn the Water Pump Switch to "ON".
  - g. With engine running, change position of Water Safety Switch to WET CUT.
  - h. Engine should continue to run.

#### OPTIONAL ELECTRIC WATER PUMP OPERATION

1. On all models equipped with electric pumps (12 V.D.C.), be sure there is water in the system AND water is being supplied to the pump. Open all water valves before turning on the pump.
2. Turn the Electric Water Pump Switch (7) ON.
3. Never interrupt the flow of water to the pump while the pump is ON.
4. CAUTION: Stopping the flow of water to or from the pump while it is ON will cause the pump fuse to blow.
5. To stop water flow, FIRST turn the Electric Water Pump Switch (7) OFF, then close all water valves.

## COOLANT REQUIREMENTS

1. You must use water when cutting with diamond blades or abrasive blades marked as "WET CUTTING BLADE". A supply of 2 ½ to 5 gallons per minute (GPM) is necessary. Attach water hose to coolant valve or pump. Adjust valves to control the flow of water.
2. For diamond blades or abrasive blades marked "DRY CUTTING BLADE", water may be used for controlling dust, but is not required for cooling.



EDCO DOES NOT RECOMMEND THE USE OF ABRASIVE BLADES.

## BLADE SELECTION

1. Choose the proper blade for your job. Significant factors that determine blade selection include:
2. What is the hardness and composition of slab.
3. Are re-bars present?
4. What is the depth of cut?
5. What is the length of cut?
6. Give your dealer complete information. Let him advise you on blade selection.
7. Always use blades with a "Drive Pin Hole" to prevent blade from slipping.

## LIFTING AND LOWERING OF BLADES:

1. Reference Figure 1.
2. Pull knob up on the Depth Control Hand Crank (1) to lift locking pin out of stop hole in saw console.
3. Turn Depth Control Hand Crank in the direction UP/DOWN as indicated by arrows on crank assembly.
4. Each complete turn of the crank will raise or lower blade approximately 3/16".
5. Continue turning in the "UP" direction until blade is clear of slab surface before starting engine.



BEFORE ATTEMPTING TO CUT . . . READ AND UNDERSTAND "SELECTING DEPTH OF CUT" INSTRUCTIONS BELOW.

## SELECTING DEPTH OF CUT

1. Depth of cut is selected by turning Depth Control Hand Crank. (1)
2. Position saw over cutting line.
3. Blade should be raised and engine at full throttle.
4. If cutting WET: Be sure water is flowing freely to the blade.
5. Pull knob up on the Depth Control Hand Crank (1) to lift locking pin out of stop hole in saw console.
6. Slowly turn hand crank in DOWN direction.
7. Continue turning until blade has penetrated slab to desired depth.
8. Each complete turn of the crank will lower blade approximately 3/16".
9. Never cut deeper than is necessary.

MAXIMUM DEPTH OF CUT:	
for 14" diameter blade.....	4 ¾"
for 16" diameter blade.....	5 ¾"
for 18" diameter blade.....	6 ¾"

The depth of cut can be controlled two different ways:

1. Mark blade prior to starting cut.
  - a. Use heavy permanent marking pen.
  - b. Measure back from the blade edge the depth you wish to cut.
  - c. Mark blade with heavy line. This line will be visible as blade is turning.
  - d. When mark reaches slab surface, cutting depth has been reached.
2. Lower blade until approximate depth has been reached.
  - a. Raise blade, counting the number of turns on the Depth Control Hand Crank and stop saw.
  - b. Move the saw away from the cut and measure depth with ruler.
  - c. Adjust depth accordingly.

Once desired depth is reached, drop lock pin into hole in console. Blade will be locked at this selected depth.

**WARNING**

CUTTING CAN BE DONE IN THE FORWARD DIRECTION ONLY.

**CUTTING SPEED**

1. The "Drive Selector Lever" (2) controls the forward and reverse movement of the saw.
2. Gradually move the Drive Selector Lever (2) from 'Neutral' to 'Forward'. Once the desired forward cutting speed is reached, turn the "Speed Control Knob" (3) counter-clockwise until the Drive Selector Lever (2) is held in place.
3. The saw will move forward in a steady-controlled manner. The Speed Control Knob is meant to hold the machine at a speed set by the operator. This feature works much like 'cruise-control' in a car.
3. NOTE: the Speed Control Knob moves a small bracket that hits against the rear of the Drive Selector Lever — holding it forward at the desired setting. To disengage, move the Drive Selector Lever to the left slightly and move lever back to neutral. To return to this pre-set speed, move the lever forward until it latches.
4. Make small speed adjustments by turning the Speed Control Knob counter-clockwise (faster) or clockwise (slower).
5. Forward cutting speed is determined by type of blade, material to be cut and depth of cut. Cut at FULL THROTTLE. Adjust forward speed to meet cutting conditions.

**WARNING**

RAISE THE SAW BLADE OUT OF THE CUT BEFORE ATTEMPTING TO TRANSPORT THE SAW.

**ROAD SPEED**

1. Road speed is attained by moving Drive Selector Lever (2) from 'Neutral' to the full 'Forward' position.
2. Saw will move forward at speeds up to 200 ft. per minute. Speed depends on engine RPM.
3. To back-up the saw: stop all forward travel, raise blade clear of slab surface, move the Drive Select Lever (2) to 'Reverse' position. For operator safety, maximum reverse speed is set at a slow walking pace.

**DRIVE MECHANISM**

1. Forward and reverse motion of the SS-16 & SS-18 is achieved through the use of a hydrostatic transmission, chain and friction drive mechanism engaging both rear wheels.
2. Spring tension keeps the Drive Roller firmly against the 8" rubber tired wheels, exerting more than enough pressure and assuring you of a smooth, even, positive drive.
3. To engage the drive mechanism, simply move the Clutch Cam Lever (10) to the "ENGAGE" position. To disengage and stop the drive mechanism, move the Clutch Cam Lever (10) to the "DISENGAGE" position.

**TO STOP CUTTING**

1. Move Clutch Cam Lever (10) to the 'DISENGAGE' position; this will stop all forward speed.
2. Return Throttle (4) to idle.
3. Rotate the Speed Control Knob (3) CLOCKWISE until the Drive Selector Lever (2) is in the neutral position. (Alternately, move the Drive Selector Lever (2) to the left slightly and move lever back to the neutral position.)
4. Turn Depth Control hand crank CLOCKWISE until blade is clear of slab.
5. Turn off optional water pump switch (7) and turn off water supply valve (8).
6. To stop engine – Return ON-OFF (5) switch to OFF position or push STOP button (5) and hold until engine stops.

**SPECIAL INSTRUCTIONS**

1. Be sure to select the proper blade for the job. See BLADE SELECTION section in this manual.
2. Never cut deeper than is necessary. See SELECTING DEPTH OF CUT section in this manual.
3. Always use blades with a "Drive Pin Hole" to prevent blade from slipping.
4. Be sure blade is properly installed on the arbor.
5. Check arbor for wear. A worn arbor is unsafe and will ruin a diamond blade. Tighten Arbor Blade Retaining Cap securely.
6. Should engine stall while cutting, raise blade out of cut before re-starting.
7. Use extreme care if lowering blade into previously made cut. Be certain the blade is aligned with cut. DO NOT twist or force blade.
8. DO NOT let engine labor. Should this occur, slow forward speed or check blade specifications to determine if a faster cutting blade is available. A worn blade will also cause engine to labor.

## LIMITED EQUIPMENT WARRANTY

Equipment Development Company, Inc. herein referred to as EDCO warrants that each new unit manufactured by EDCO to be free from defects in material and workmanship in normal use and service for a period of (1) one year (except in the case of cutter drum assembly on all model concrete asphalt planes, in which case the warranty period shall be 90 days) from date of shipment to the original retail or equipment rental center owner.

EDCO will, at its option, repair or replace, at the EDCO factory or at a point designated by EDCO any part, which shall appear to the satisfaction of EDCO inspection to have been defective in material or workmanship.

This warranty does not apply to failure occurring as the result of abuse, misuse, negligent repairs, corrosion, erosion, normal wear and tear, alterations or modifications made to the product without express written consent of EDCO; or failure to follow the recommended operating practices and maintenance procedures as provided in the products operating and maintenance manuals.

This warranty does not obligate EDCO to bear any transportation charges in connection with the replacement or repair of defective parts. This warranty does not obligate EDCO to bear the expenses for travel time or of personnel in connection with any service calls.

Accessories or equipment furnished or installed on the product by EDCO but manufactured by others, including but not limited to engines, motors, electrical equipment, transmissions, etc., shall carry the accessory manufacturers' own warranty.

**THIS WARRANTY IS IN LIEU OF ALL OTHER WARRANTIES, EXPRESSED OR IMPLIED, OR STATUTORY, INCLUDING ANY WARRANTIES OF MERCHANTABILITY OR OF FITNESS FOR A PARTICULAR PURPOSE.**

### LIABILITY LIMITATIONS

The remedies of the user set forth under provisions of warranty outlined above are the exclusive and total liability of EDCO with the respect to their sale or the equipment and service furnished hereunder, in connection with the performance or breach thereof, or from the sale, delivery, installation, repair or technical direction covered by or furnished under the sale, whether based on contract, warranty, negligence, indemnity, strict liability, or otherwise shall not exceed the purchase price of the unit of equipment upon which such liability is based.

EDCO will not in any event be liable to the user, any successors in interest or any beneficiary or assignee relating to this sale for any consequential, incidental, indirect, special or punitive damages arising out of this sale or any breach thereof, or any defects on, or failure of, or malfunction of the equipment under this sale whether based upon loss of use, lost profits or revenue, interest, lost goodwill, work stoppage, impairment of other goods, loss by reason of shutdown or non-operation, increased expenses of operation of the equipment, cost of purchase or replacement power of claims of users or customers of the users for service interruption whether or not such loss or damage is based on contract, warranty, negligence, indemnity, strict liability, or otherwise.

EDCO reserves the right to modify, alter and improve any part or parts without incurring any obligation to replace any part or parts previously sold without such modified, altered or improved part or parts.

No person is authorized to give any other warranty or to assume any additional obligation on EDCO's behalf unless made in writing and signed by an officer of EDCO.

Equipment Development Company, Inc.

**USE ONLY GENUINE EDCO PARTS AND ACCESSORIES**  
For your own safety, the safety of others and the life of your machine

#### HOW TO ORDER REPAIR PARTS

To insure product safety and reliability, always use genuine EDCO replacement parts when making repairs to the equipment.

When ordering parts, please specify the MODEL and SERIAL NUMBER of the machine as given on the NAME PLATE. In addition, give part number, description and quantity as listed on the parts list.

Please note: Due to improvements and changes in the equipment, the illustrations shown may be different than the actual machine.

Printed in USA



**EQUIPMENT DEVELOPMENT COMPANY, INC.**

100 THOMAS JOHNSON DRIVE, FREDERICK, MD 21702-4600 USA  
Phone (301) 663-1600 Toll Free 1-800-638-3326 Fax (301) 663-1607 Fax Free 1-800-447-3326

©1997