

REVISED STARTING
SERIAL # 100710165

PARTS LIST MANUAL GASOLINE POWER TROWEL



SKU #	MODEL #	SIZE	RPM	ENGINE MODEL
85400	T244B-4H	24"	140	HONDA GX120 GASOLINE ENGINE WITH DUAL ELEMENT AIR CLEANER
85600	T244BRS-4H	24"	70	
85500	T304B-5.5H	30"	140	HONDA GX160 GASOLINE ENGINE WITH DUAL ELEMENT AIR CLEANER
85700	T304BRS-5.5H	30"	70	
85100	T364B-5.5H	36"	140	
85800	T364BRS-5.5H	36"	70	HONDA GX270 GASOLINE ENGINE WITH DUAL ELEMENT AIR CLEANER
85300	T364B-9H	36"	140	
85900	T364BRS-9H	36"	70	
85200	T464B-9H	46"	140	
86100	T464BRS-9H	46"	70	



A Division of Equipment Development Company, Inc.

100 Thomas Johnson Drive, Frederick, MD 21702-4600 USA

Phone (301) 663-1600 • 1-800-638-3326

Fax (301) 663-1607 • 1-800-447-3326

Website: www.edcoinc.com

Email: sales@edcoinc.com

Printed in USA

JWA ©2010

READ AND UNDERSTAND THE OPERATORS INSTRUCTION MANUAL THOROUGHLY BEFORE ATTEMPTING TO OPERATE THIS EQUIPMENT. Death or serious injury could occur if this machine is used improperly.



SAFETY MESSAGES



The safety instructions are preceded by a graphic alert message of DANGER, WARNING, or CAUTION.



Indicates an imminent hazard which, if not avoided, will result in death or serious injury.



Indicates an imminent hazard which, if not avoided, can result in death or serious injury.



Indicates hazards which, if not avoided, could result in serious injury and or damage to the equipment.

GASOLINE Powered Equipment



- Do not operate gasoline powered equipment without adequate ventilation. Carbon monoxide is an invisible, odorless gas that can kill.

ELECTRICAL Powered Equipment



- ELECTRICAL HAZARD** - Be sure equipment is properly grounded. Failure to comply could kill or result in serious injury.



The engine exhaust from this product contains chemicals known to the State of California to cause cancer, birth defects or other reproductive harm.

GENERAL INSTRUCTIONS



- You must read and understand the operators instruction manual and all other manuals associated with this machine. For your safety and the safety of others around you, it is extremely important to fully understand how to operate this machine in the way it was intended. Different model machines or older/newer versions of the same model may have different parts and controls that you need to understand. If instructions are not readable or available DO NOT USE this machine and contact the factory for a replacement Manual.
- You must be able to physically handle the bulk weight and power of this machine. If not properly controlled this machine can cause death or serious injury.
- Do not operate this machine in an impaired mental state. You must be able to exercise good judgement and reactions to maintain a safe working environment.
- This is a "one person" machine which means only one operator can be operating the machine at any one time. For the safety of others, maintain a safe operating distance to other personnel. Your work area should be defined and appropriately marked so bystanders and coworkers do not stand or walk near this machine and end up seriously injured by flying debris or exposing them to harmful noise or dust.
- This equipment is for Commercial use. Although this is a "one person" machine your work team should understand how to shut this machine off and quickly get medical help if an accident strikes the operator.
- Keep all guards in place during operation. The guards are to provide protection from inadvertent contact with dangerous moving parts, pinch points, or hot surfaces.
- Wear appropriate Personal Protective Equipment (PPE) including safety glasses, safety boots, work gloves, respiratory protection, hearing protection, and head protection. Do not wear loose clothing that can get tangled in moving parts. Failure to do so could result

in dismemberment or death. **Wear an approved respirator when removing hazardous materials or when grinding/cutting dry materials. Some dust particles such as concrete dust can contain silicate particles which can cause silicosis (a very serious lung disease). Contact NIOSH or OSHA for further details. When wet grinding/cutting, avoid contact with the concrete/asphalt slurry which can cause serious skin irritations.**

- You must maintain this machine per the maintenance schedule in the operator manual. Remember before adjusting, servicing, or fueling this machine, disconnect the source of power to the machine by disconnecting the spark plug (Gas models), or by unplugging the electrical power cord (electric models) or air hose (Pneumatic models) AT THE MACHINE so you can assure yourself it remains unplugged while you are working on it. Do not modify this machine. Use only genuine EDCO parts and accessories. Repairs and service should be performed by approved EDCO dealers or authorized technicians.
- You should look carefully around the area before you begin work so you can identify potential hazards such as deck inserts, pipes, columns, openings, electrical cords or outlets, or any other objects protruding from the slab surface.
- This machine has no brain so you must use your own. There is no substitute for safety. The safety decals on the machine are to serve as a reminder for information you must already know before you begin using this machine. Take a moment to reread the safety decals each time you use the machine. If your machine is missing any decals, contact the factory for a replacement (EDCO 1-800-638-3326).

PARTS LIST MANUAL

GASOLINE POWER TROWEL

TABLE OF CONTENTS

<u>Section</u>	<u>Page Number</u>
Safety Messages and General Instructions	2
How To Order Replacement Parts	3
Illustration 1: Handle Bar, Pitch Lever & Control Knob Grouping	4, 5
Illustration 2: Handle Adjustable Belly Bar Grouping	6
Illustration 3: Safety Stop Switch Grouping	7
Illustration 4: Frame , Transmission & Spider Grouping	8, 9
Illustration 5: Spider Assembly	10
Illustration 6: Bolt-On Blades & Adapter for 24" Trowel	11
Illustration 7: Bolt-On Blades & Adapter for 30" Trowel	12
Illustration 8: Bolt-On Blades & Adapter for 36" Trowel	13
Illustration 9: Bolt-On Blades & Adapter for 46" Trowel	14
Illustration 10: Optional Quick Change Blades & Adapters	15
Illustration 11: Optional 36" Float Pan	16
Illustration 12: Lifting Bail & Lift Handle Grouping	17
Illustration 13: Engine Grouping for Honda GX120 & GX160	18, 19
Illustration 14: Engine Grouping for Honda GX270	20, 21
Illustration 15: Wiring Diagram	22
Illustration 16: Optional "Tote-A-Trowel"	23
Limited Equipment Warranty of Sale - Terms & Conditions	24 (Back Page)

HOW TO ORDER REPLACEMENT PARTS

- ❑ To insure product safety and reliability, always use genuine EDCO replacement parts when making repairs to the equipment.
- ❑ When calling for parts, specify the MODEL and SERIAL number of the machine, which can be found on the NAME PLATE. Keep that information in the space provided. In addition to this information, give part number, description, and quantity as listed on the parts list to your parts representative.
- ❑ Please note: Due to improvements and changes in the equipment, the illustrations shown may be different than the actual machine.

FILL IN INFORMATION BELOW

Date of Purchase _____

Model # _____

Serial # _____

SKU # _____



A Division of Equipment Development Company, Inc.

100 Thomas Johnson Drive, Frederick, MD 21702-4600 USA

Phone (301) 663-1600 • 1-800-638-3326

Fax (301) 663-1607 • 1-800-447-3326

Website: www.edcoinc.com

Email: sales@edcoinc.com

Printed in USA

JWA ©2010

Page 3

ILLUSTRATION 1: HANDLE BAR, PITCH LEVER & CONTROL KNOB GROUPING

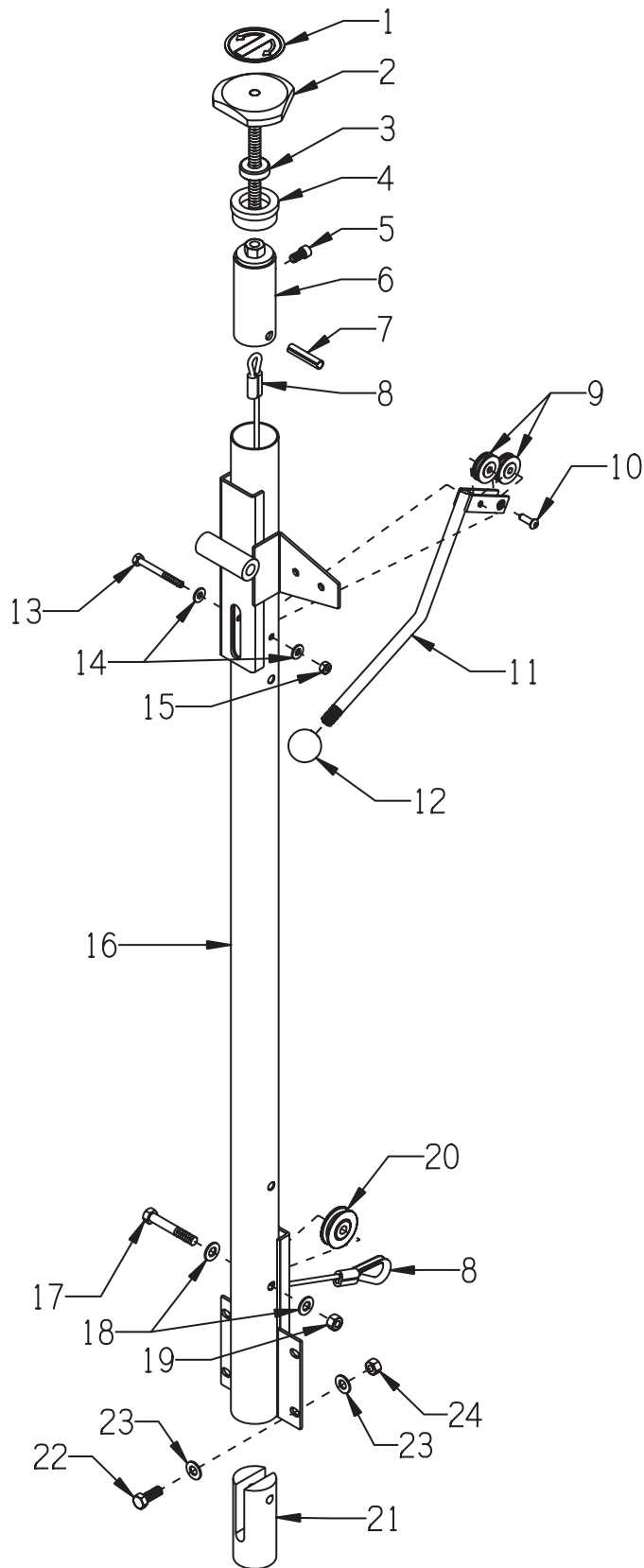

**PARTS LISTING - ILLUSTRATION 1 :
HANDLE BAR, PITCH LEVER & CONTROL KNOB GROUPING**

ITEM #	PART #	DESCRIPTION	QTY.
1	3661	DECAL, BLADE ANGLE - FLAT/TILT	1
2	49014	KNOB, CONTROL W/ 1/2-13 X 6-3/4"ROD	1
3	3642	BEARING, THRUST BALL 1/2	1
4	36078	HANDLE TOP INSERT	1
5	11639	SCREW, SKT. HD. CAP 5/16-18 X 5/8	1
6	36080	LINKAGE	1
7	10063	PIN, ROLL 3/8 X 2	1
8	36082	CABLE, CONTROL 3/16 X 51"L INCLUDES:	1
	4610	CABLE, THIMBLE 3/16"	1
	3618	SLEEVE, 3/16" CABLE OVAL NICOPRESS	2
9	14082	PULLEY BEARING 1-1/4DIA. X 1/4BORE	2
10	10884	SCREW, SKT. BUTTON HD. 1/4-20 X 3/4	1
11	36081	LEVER, PITCH	1
12	14023	KNOB, BALL 1-3/8 W/ 1/2-13THD, BLK.	1
13	11658	SCREW, CAP 1/4-20 X 2-3/4 (CUT 2-1/2"L)	1
14	10602	WASHER, FLAT 1/4 SAE	2
15	10150	NUT, HEX NYLON LOCK 1/4-20	1
16	36070	HANDLE BAR	1
17	10393	SCREW, CAP 3/8-24 X 2-1/2	1
18	10025	WASHER, FLAT 3/8 SAE	2
19	10058	NUT, LOCK 3/8-24 W/ NYLON PATCH	1
20	3621	PULLEY BEARING 1-3/4DIA. X 3/8BORE	1
21	36077	ROLLER GUIDE	1
22	10021	SCREW, CAP 3/8-24 X 1	4
23	10025	WASHER, FLAT 3/8 SAE	4
24	10004	NUT, LOCK 3/8-24	4



A Division of Equipment Development Company, Inc.

100 Thomas Johnson Drive, Frederick, MD 21702-4600 USA

Phone (301) 663-1600 • 1-800-638-3326

Fax (301) 663-1607 • 1-800-447-3326

Website: www.edcoinc.com

Email: sales@edcoinc.com

Printed in USA

JWA ©2010

Page 5

ILLUSTRATION 2 : ADJUSTABLE HANDLE BELLY BAR GROUPING

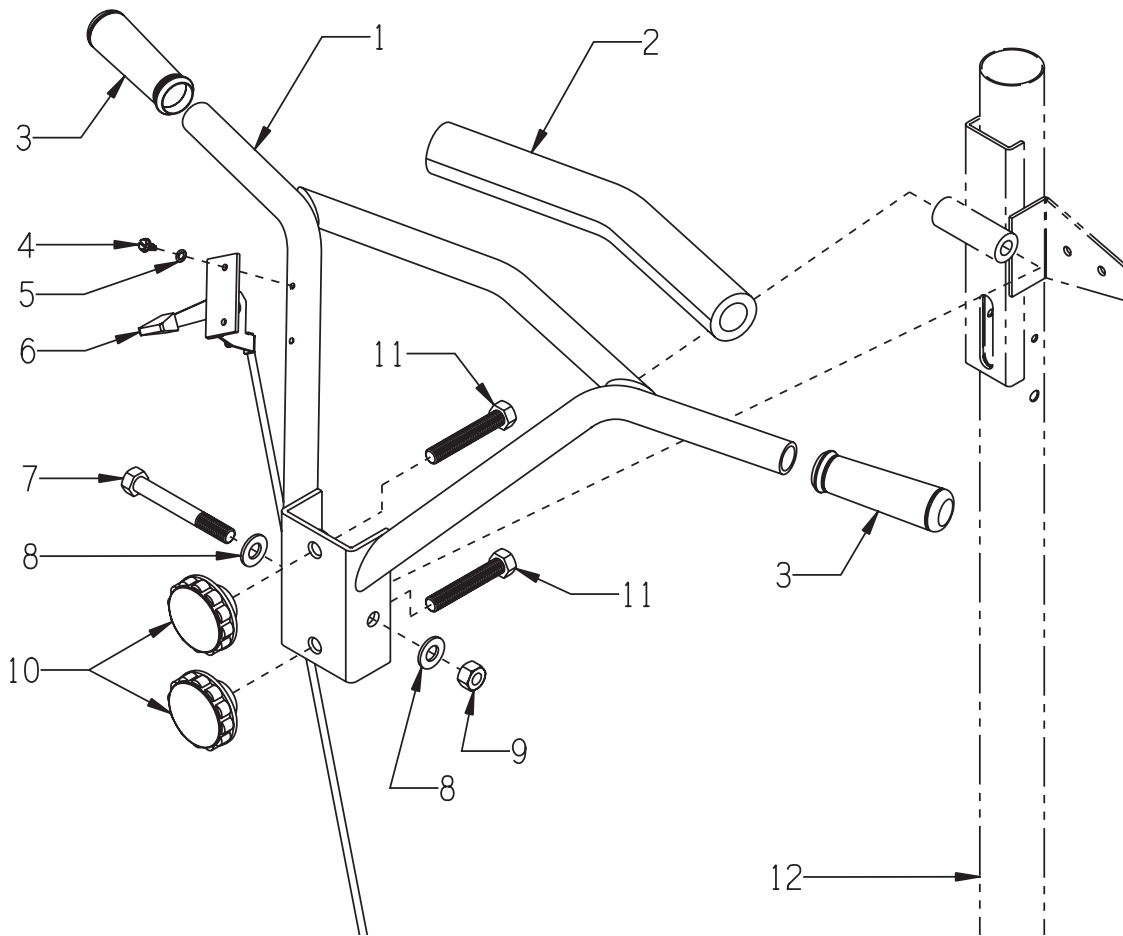

ITEM #	PART #	DESCRIPTION	QTY.
1	36071	HANDLE BELLY BAR, ADJUSTABLE	1
2	36083	PADDING, BELLY BAR	1
3	10608	GRIP, HAND 1" MODEL AT	2
4	10877	SCREW, CAP STSHW 10-24 X 1/2	2
5	10038	WASHER, LOCK 1/4	2
6	36012A	CABLE, THROTTLE CONTROL 54", TROWEL	1
7	81001	SCREW, CAP 1/2-13 X 4	1
8	10312	WASHER, FLAT 1/2 SAE	2
9	10155	NUT, HEX NYLON LOCK 1/2-13	1
10	36063	KNOB, FLUTED 1/2-13 X 2-1/2"DIA.	2
11	10340	BOLT, TAP 1/2-13 X 3 (FULL THREAD)	2
12	36070	HANDLE BAR (REF. TO ILLUS. 1, ITEM 16)	1

**ILLUSTRATION 3 :
SAFETY STOP SWITCH GROUPING**

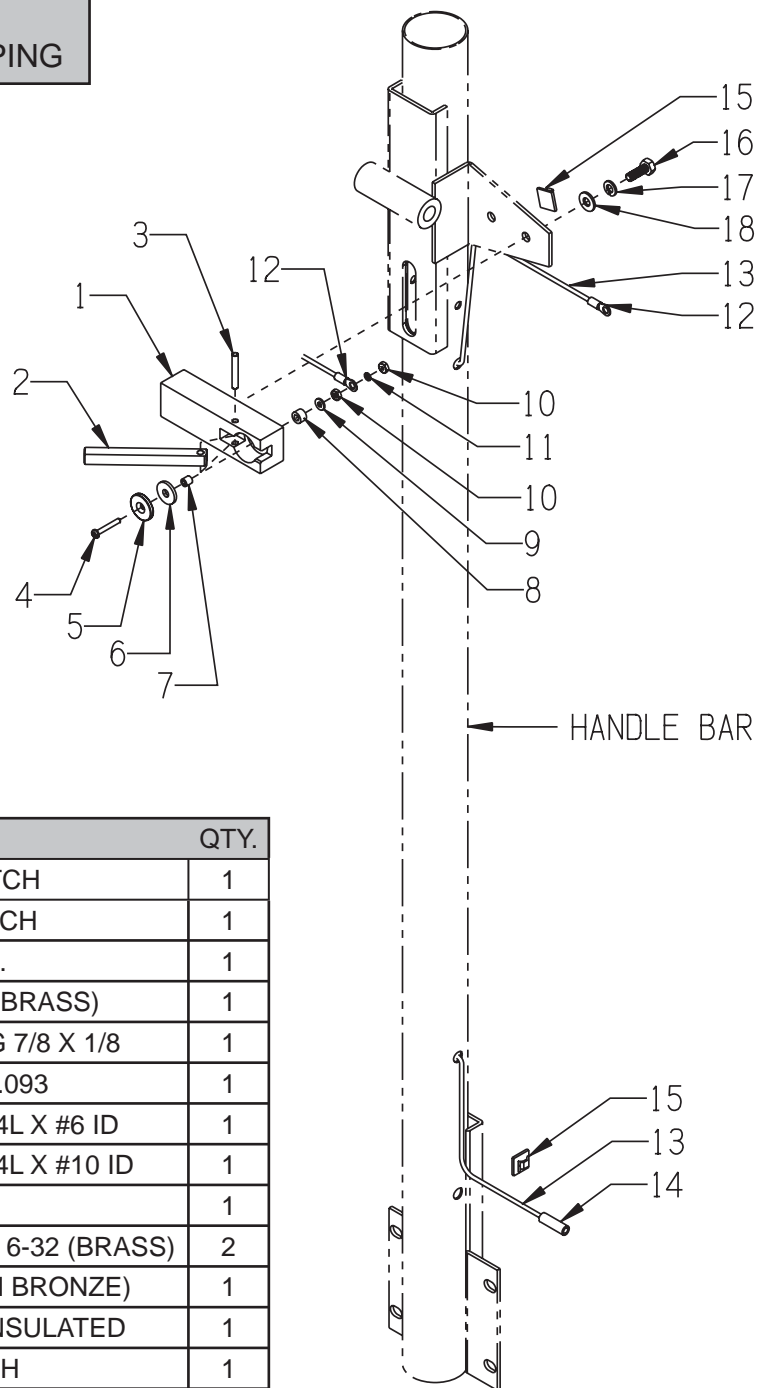

ITEM #	PART #	DESCRIPTION	QTY.
1	36073	BLOCK, SAFETY STOP SWITCH	1
2	36074	LEVER, SAFETY STOP SWITCH	1
3	36035	PIN, DOWEL 3/16 X 1-1/4 S.S.	1
4	10389	SCREW, MACHINE 6-32 X 1 (BRASS)	1
5	36064	MAGNET, NEODYMIUM RING 7/8 X 1/8	1
6	15187	WASHER, FIBER .75 X .25 X .093	1
7	36038	SPACER, NYLON 1/4OD X 1/4L X #6 ID	1
8	36037	SPACER, NYLON 3/8OD X 1/4L X #10 ID	1
9	36040	WASHER, FLAT #6 (BRASS)	1
10	36039	NUT, MACHINE SCREW HEX 6-32 (BRASS)	2
11	36041	WASHER, LOCK #6 (SILICON BRONZE)	1
12	11642	TERM., RING #6 16-14 GA. INSULATED	1
13	36090	WIRE, SAFETY STOP SWITCH	1
14	11568	CONNECTOR, LINE STD. 16-14GA.(BLUE)	1
15	36042	CLIP, NATURAL CORD, 1/8" X 1/4"	2
16	10018	SCREW, CAP 1/4-20 X 3/4	2
17	10038	WASHER, LOCK 1/4	2
18	10602	WASHER, FLAT 1/4 SAE	2



A Division of Equipment Development Company, Inc.

100 Thomas Johnson Drive, Frederick, MD 21702-4600 USA

Phone (301) 663-1600 • 1-800-638-3326

Fax (301) 663-1607 • 1-800-447-3326

Website: www.edcoinc.com

Email: sales@edcoinc.com

Printed in USA

JWA ©2010

Page 7

ILLUSTRATION 4 : FRAME, TRANSMISSION & SPIDER GROUPING

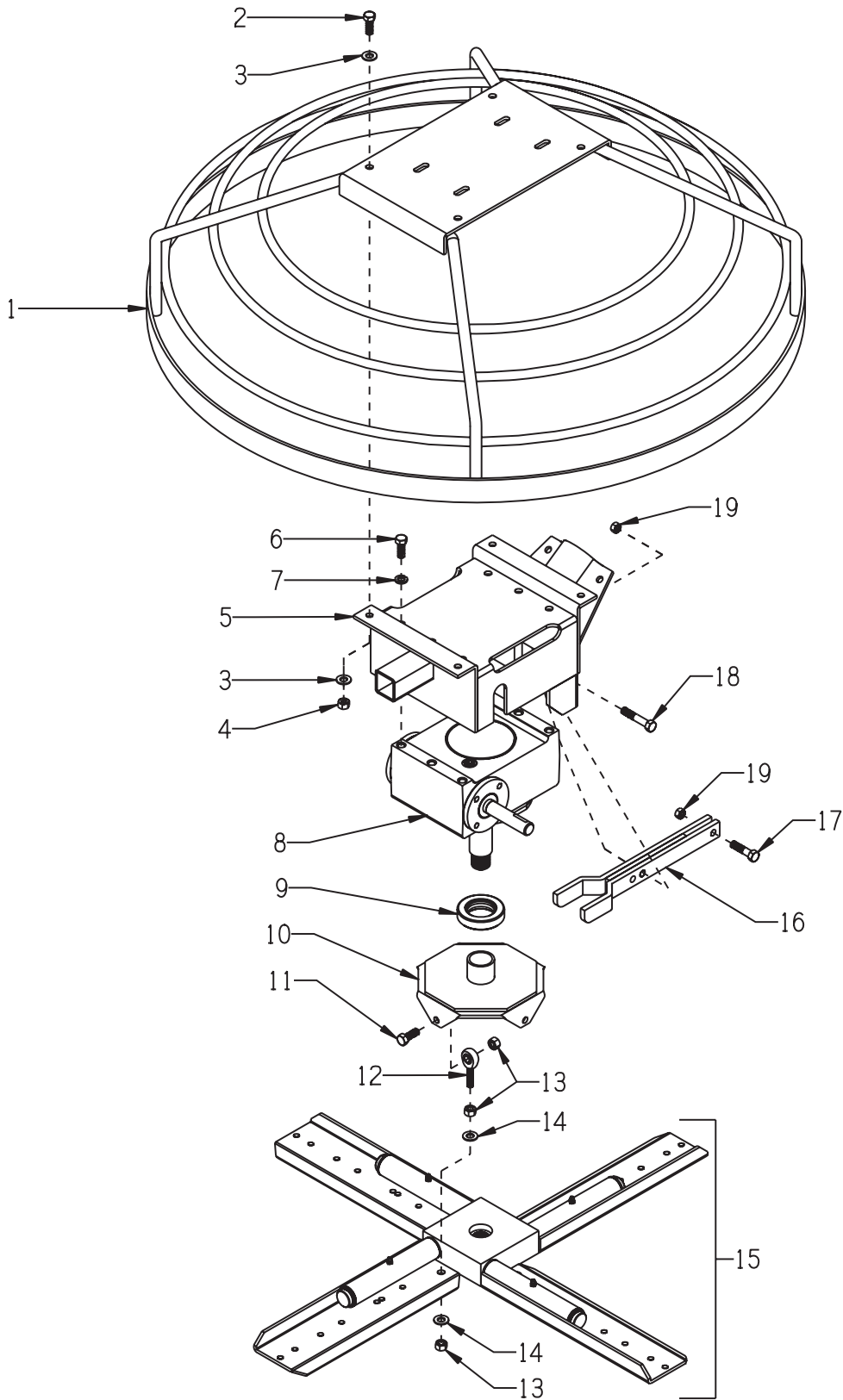

PARTS LISTING - ILLUSTRATION 4 : FRAME, TRANSMISSION & SPIDER GROUPING			
ITEM #	PART #	DESCRIPTION	QTY.
1	36065 36066 36067 36068	FRAME & GUARD RING 24" TROWEL 30" TROWEL 36" TROWEL 46" TROWEL	1
2	10309 10029	SCREW, CAP 3/8-24 X 1-1/4 (HONDA GX120 & GX160 ONLY) 3/8-24 X 1-3/4 (HONDA GX270 ONLY)	4 4
3	10025	WASHER, FLAT 3/8 SAE	8
4	10004	NUT, LOCK 3/8-24	4
5	36069	MOUNT, TRANSMISSION	1
6	10055	SCREW, CAP 3/8-16 X 1	6
7	10025	WASHER, FLAT 3/8 SAE	6
8	3664 3664-RS	TRANSMISSION 20:1 RATIO - STANDARD SPEED (140 RPM MODELS) 40:1 RATIO - REDUCED SPEED (70 RPM MODELS)	1
9	3609	BEARING, THRUST BALL 1-1/2"ID X 2-19/32"OD X 5/8"THK	1
10	3626 4603	PLATE, PITCH ADJUSTMENT 24, 30, & 36" TROWELS 46" TROWELS	1
11	10021 10322	SCREW, CAP SCREW, CAP 3/8-24 X 1 (24, 30, & 36" TROWELS) SCREW, CAP 1/2-20 X 2 (46" TROWELS, ON INSIDE)	4
12	3605 4805	ROD END, MALE 3/8-24 (24, 30, & 36" TROWELS, AS SHOWN) 1/2-20 (46" TROWELS, MOUNTED ON OUTSIDE)	4
13	10004 10205	NUT, LOCK 3/8-24 (24, 30, & 36" TROWELS) 1/2-20 (46" TROWELS)	12 16
14	10025 10312	WASHER, FLAT 3/8 SAE (24, 30, & 36" TROWELS) 1/2 SAE (46" TROWELS)	8
15	36084 36085 36086 36087 36093	SPIDER ASSEMBLY (REFER TO ILLUS. 7) 24" TROWEL (8-1/2" ARMS) 30" TROWEL (12" ARMS) 36" TROWEL (13" ARMS) 46" TROWEL (15-1/4" ARMS) 46" TROWEL (17-1/4" ARMS)	1
16	3625	FORK	1
17	10816	SCREW, CAP 3/8-24 X 1-1/2	1
18	10030	SCREW, CAP 3/8-24 X 2	1
19	10004	NUT, LOCK 3/8-24	2



A Division of Equipment Development Company, Inc.

100 Thomas Johnson Drive, Frederick, MD 21702-4600 USA

Phone (301) 663-1600 • 1-800-638-3326

Fax (301) 663-1607 • 1-800-447-3326

Website: www.edcoinc.com

Email: sales@edcoinc.com

Printed in USA

JWA ©2010

Page 9

ILLUSTRATION 5: SPIDER ASSEMBLY

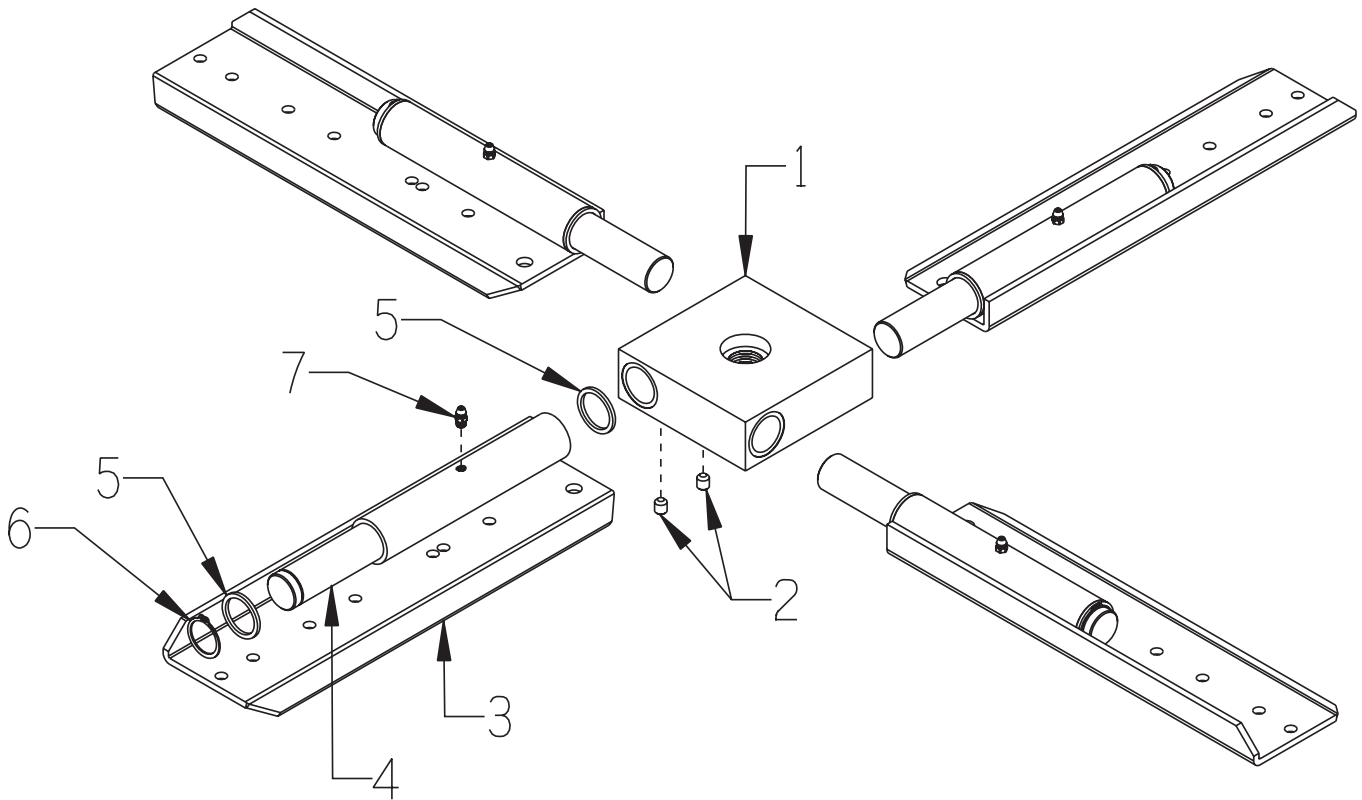

ITEM #	PART #	DESCRIPTION	QTY.
1	3637	HUB, 4 BLADE TROWEL	1
2	10052	SCREW, SET 5/16-18 X 3/8	8
3	2402 3666 36007 4618 4606	ARM, BLADE 8-1/2" ARM, 24" TROWEL ,BOLT-ON BLADES 12" ARM, 30" TROWEL, BOLT-ON OR QUICK-CHANGE 13" ARM, 36" TROWEL, BOLT-ON OR QUICK-CHANGE 15-1/4" ARM, 46" TROWEL, BOLT-ON BLADES 17-1/4" ARM, 46" TROWEL, QUICK-CHANGE BLADES	4
4	3635 4604	SHAFT, BLADE ARM 9-11/16"L SHAFT (24", 30", & 36" TROWEL) 13-15/16"L SHAFT (46" TROWEL)	4
5	3629	SPACER, ALUM. 1.25 X 1.017 X .090	4
6	10906	RETAINING RING, EXT. 1"	4
7	10808	FITTING, GREASE 1/4-28 STRAIGHT	4

**ILLUSTRATION 6:
BOLT-ON BLADES & ADAPTER
FOR 24" TROWEL**

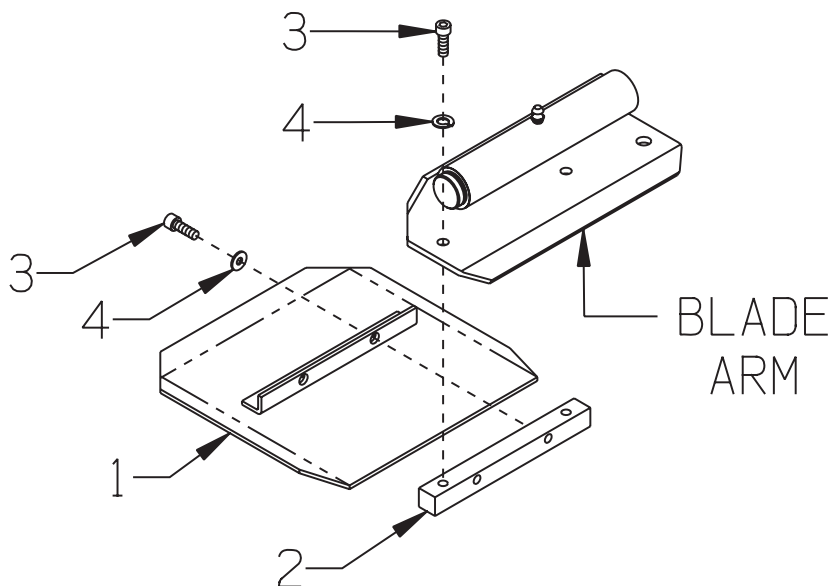

ITEM #	PART #	DESCRIPTION	QTY.
1	40470 40480 40490	BLADE C-4 COMBINATION TROWEL BLADE 8 X 8 (SHOWN) F-4 FINISH TROWEL BLADE 6 X 8 M-4 FLOAT TROWEL BLADE 9 X 8	4
2	2406	BAR, BLADE MOUNTING 5/8"SQ. X 6"	4
3	11639	SCREW, SKT. HD. CAP 5/16-18 X 5/8	16
4	10801	WASHER, LOCK 5/16	16



A Division of Equipment Development Company, Inc.

100 Thomas Johnson Drive, Frederick, MD 21702-4600 USA

Phone (301) 663-1600 • 1-800-638-3326

Fax (301) 663-1607 • 1-800-447-3326

Website: www.edcoinc.com

Email: sales@edcoinc.com

Printed in USA

JWA ©2010

Page 11

**ILLUSTRATION 7:
BOLT-ON BLADES & ADAPTER
FOR 30" TROWEL**

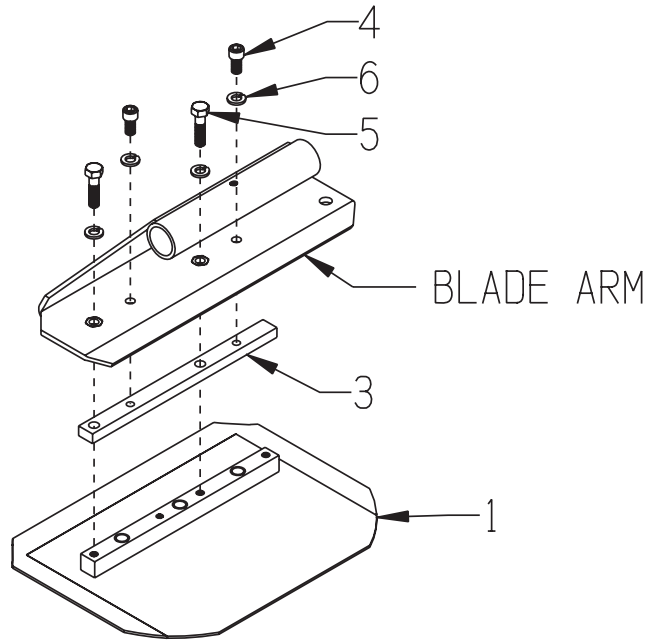

NOTE:
A FLOAT BLADE IS NOT
USED WITH THIS SET-UP.

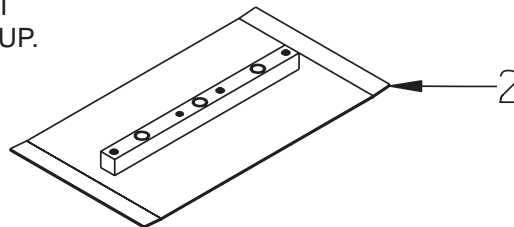

ITEM #	PART #	DESCRIPTION	QTY.
1	40270-C	C-2C COMBINATION TROWEL BLADE 8 X 10-1/2	4
2	40280-C	F-2C FINISH TROWEL BLADE 6 X 10-1/2	4
3	3639	ADAPTER BAR 3/8" X 5/8" X 8-1/4"	4
4	11639	SCREW, SKT. HD. CAP 5/16-18 X 5/8	8
5	10606	SCREW, HEX HD. CAP 5/16-18 X 1-1/4	8
6	10801	WASHER, LOCK 5/16	20

**ILLUSTRATION 8:
BOLT-ON BLADES & ADAPTER
FOR 36" TROWEL**

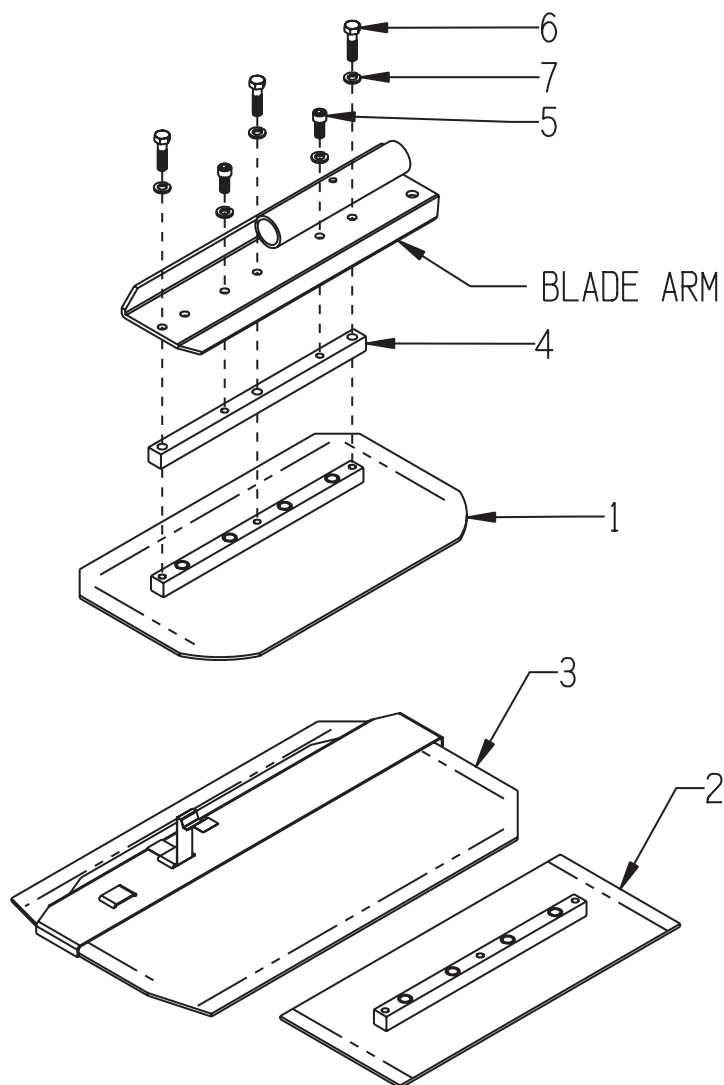

ITEM #	PART #	DESCRIPTION	QTY.
1	40040-C	C-1C COMBINATION TROWEL BLADE 8 X 14	4
2	40050-C	F-1C FINISH TROWEL BLADE 6 X 14	4
3	40060-CE	M-1CE FLOAT TROWEL BLADE 10 X 14 (SLIPS OVER FINISH BLADE)	4
4	36016	ADAPTER BAR 5/8"SQ. X 10-1/4"	4
5	11639	SCREW, SKT. HD. CAP 5/16-18 X 5/8	8
6	10606	SCREW, HEX HD. CAP 5/16-18 X 1-1/4	12
7	10801	WASHER, LOCK 5/16	20

**ILLUSTRATION 9:
BOLT-ON BLADES & ADAPTER
FOR 46" TROWEL**

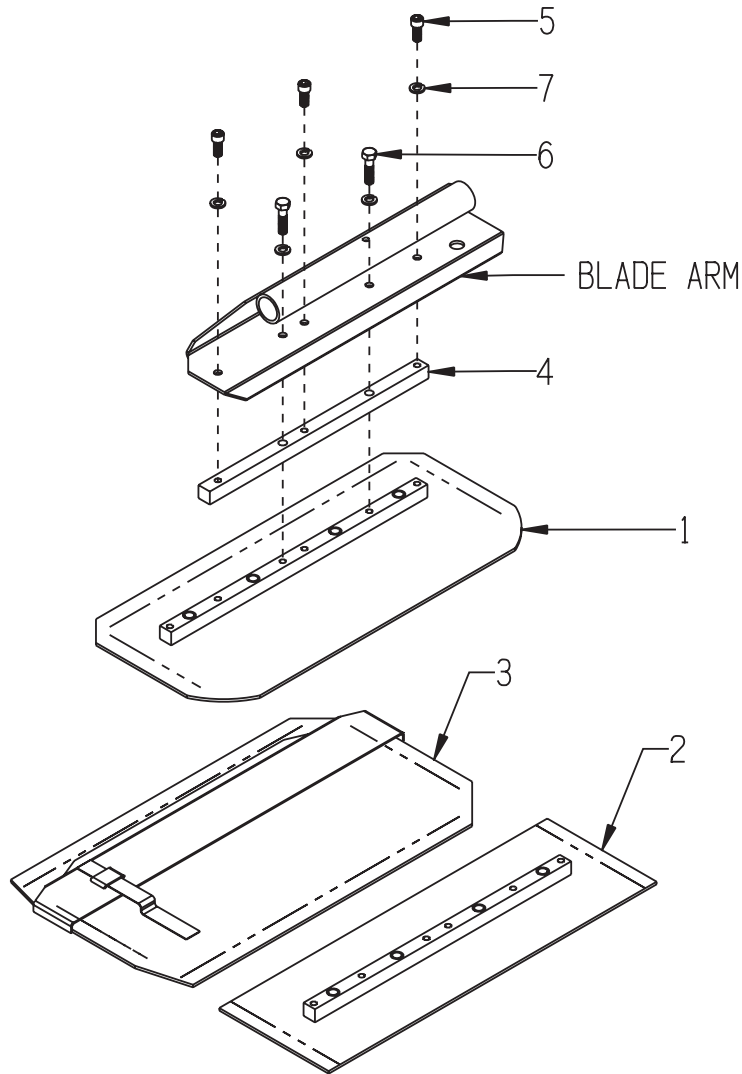

ITEM #	PART #	DESCRIPTION	QTY.
1	40070-C	C-3C COMBINATION TROWEL BLADE 8 X 18	4
2	40080-C	F-3C FINISH TROWEL BLADE 6 X 18	4
3	40090-C	M-3C FLOAT TROWEL BLADE 10 X 18 (SLIPS OVER FINISH BLADE)	4
4	4619	ADAPTER BAR 5/8'SQ. X 12"	4
5	11639	SCREW, SKT. HD. CAP 5/16-18 X 5/8	12
6	10606	SCREW, HEX HD. CAP 5/16-18 X 1-1/4	8
7	10801	WASHER, LOCK 5/16	20

**ILLUSTRATION 10:
OPTIONAL QUICK CHANGE BLADES & ADAPTERS
FOR 30", 36", & 46" TROWELS**

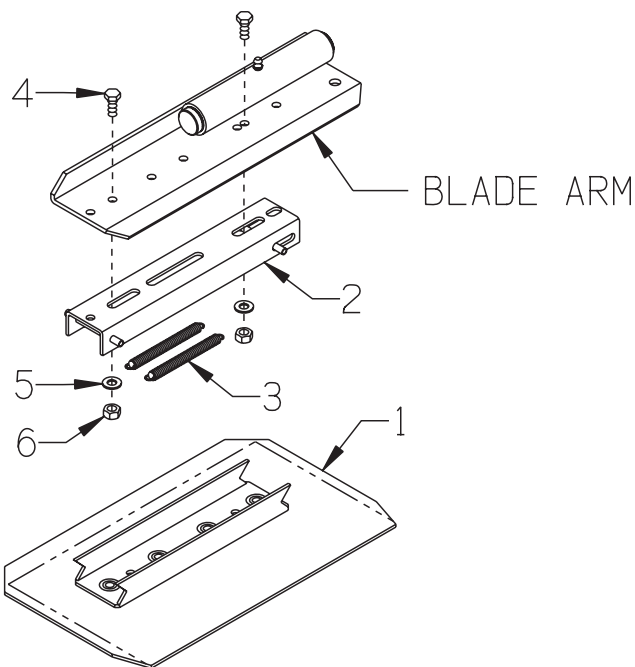

ITEM #	PART #	DESCRIPTION	QTY.
1	40270 40040 40070	COMBINATION BLADE (SHOWN) C-2, 8" x 11" C-1, 8" x 14" C-3, 8" x 18"	4
1	40290 40060 40090	FLOAT BLADE M-2, 9" x 11" M-1, 9" x 14" M-3, 9" x 18"	4
1	40280 40050 40080	FINISH BLADE F-2, 6" x 11" F-1, 6" x 14" F-3, 6" x 18"	4
2	40197 40237	ADAPTER COMPLETE (INCLUDES SPRINGS, ITEM 3) "A", 30" & 36" TROWEL, 10-1/16"L (SHOWN) "B", 46" TROWEL, 14-3/16"L	4
3	3636 4605	SPRING, EXTENSION 6"L ("A" ADAPTER) 11-1/2"L ("B" ADAPTER)	8
4	10053	SCREW, CAP 5/16-18 X 3/4	8/12
5	10213	WASHER, FLAT 5/16 SAE	8/12
6	10807	NUT, LOCK 5/16-18	8/12



A Division of Equipment Development Company, Inc.

100 Thomas Johnson Drive, Frederick, MD 21702-4600 USA

Phone (301) 663-1600 • 1-800-638-3326

Fax (301) 663-1607 • 1-800-447-3326

Website: www.edcoinc.com

Email: sales@edcoinc.com

Printed in USA

JWA ©2010

Page 15

ILLUSTRATION 11:
OPTIONAL 36" FLOAT PAN

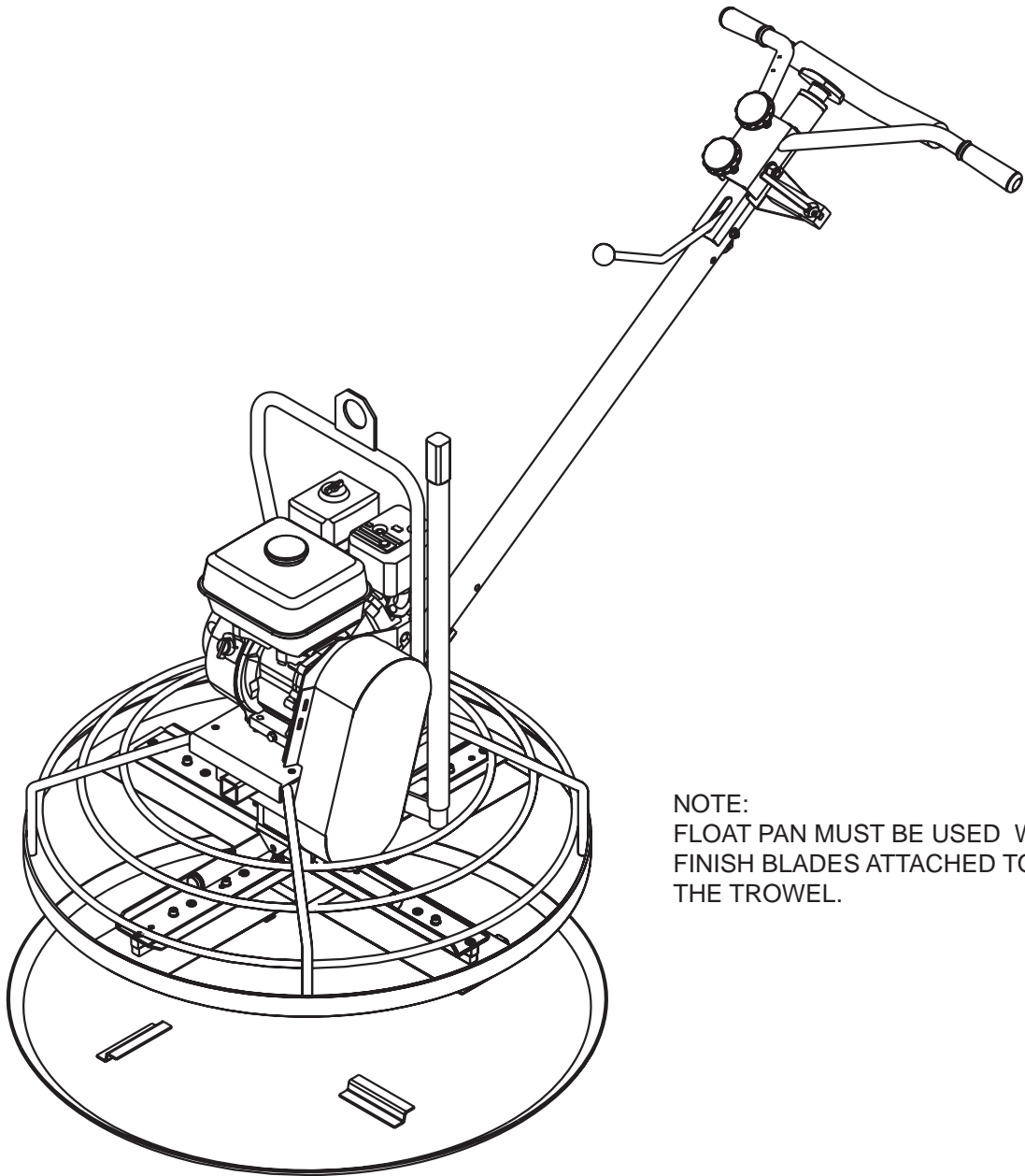

NOTE:
FLOAT PAN MUST BE USED WITH
FINISH BLADES ATTACHED TO
THE TROWEL.

PART # 40710
WFP-36 PRO FLOAT PAN
MILD DISH

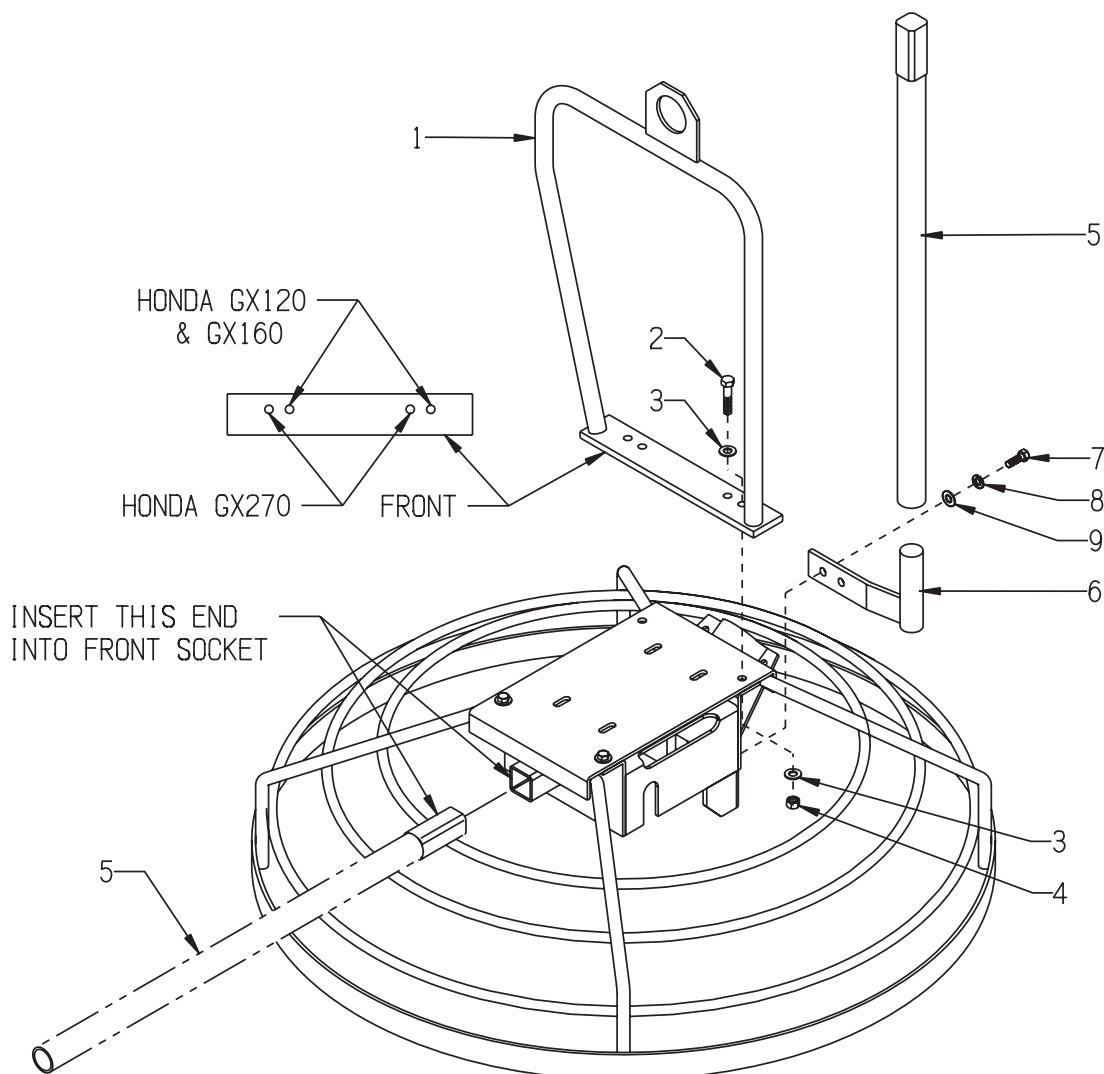
ILLUSTRATION 12: LIFTING BAIL & LIFT HANDLE GROUPING

ITEM #	PART #	DESCRIPTION	QTY.
1	36098	LIFTING BAIL, GASOLINE TROWEL	1
2	10309	SCREW, CAP 3/8-24 X 1-1/4 (HONDA GX120 & GX160 ONLY)	4
	10029	3/8-24 X 1-3/4 (HONDA GX270 ONLY)	4
3	10025	WASHER, FLAT 3/8 SAE	4
4	10004	NUT, LOCK 3/8-24	4
5	36091	HANDLE, LIFT	1
6	36092	HOLDER, LIFT HANDLE	1
7	10021	SCREW, CAP 3/8-24 X 1	2
8	10811	WASHER, LOCK 3/8	2
9	10025	WASHER, FLAT 3/8 SAE	2

**ILLUSTRATION 13: ENGINE GROUPING
FOR HONDA GX120 & GX160**

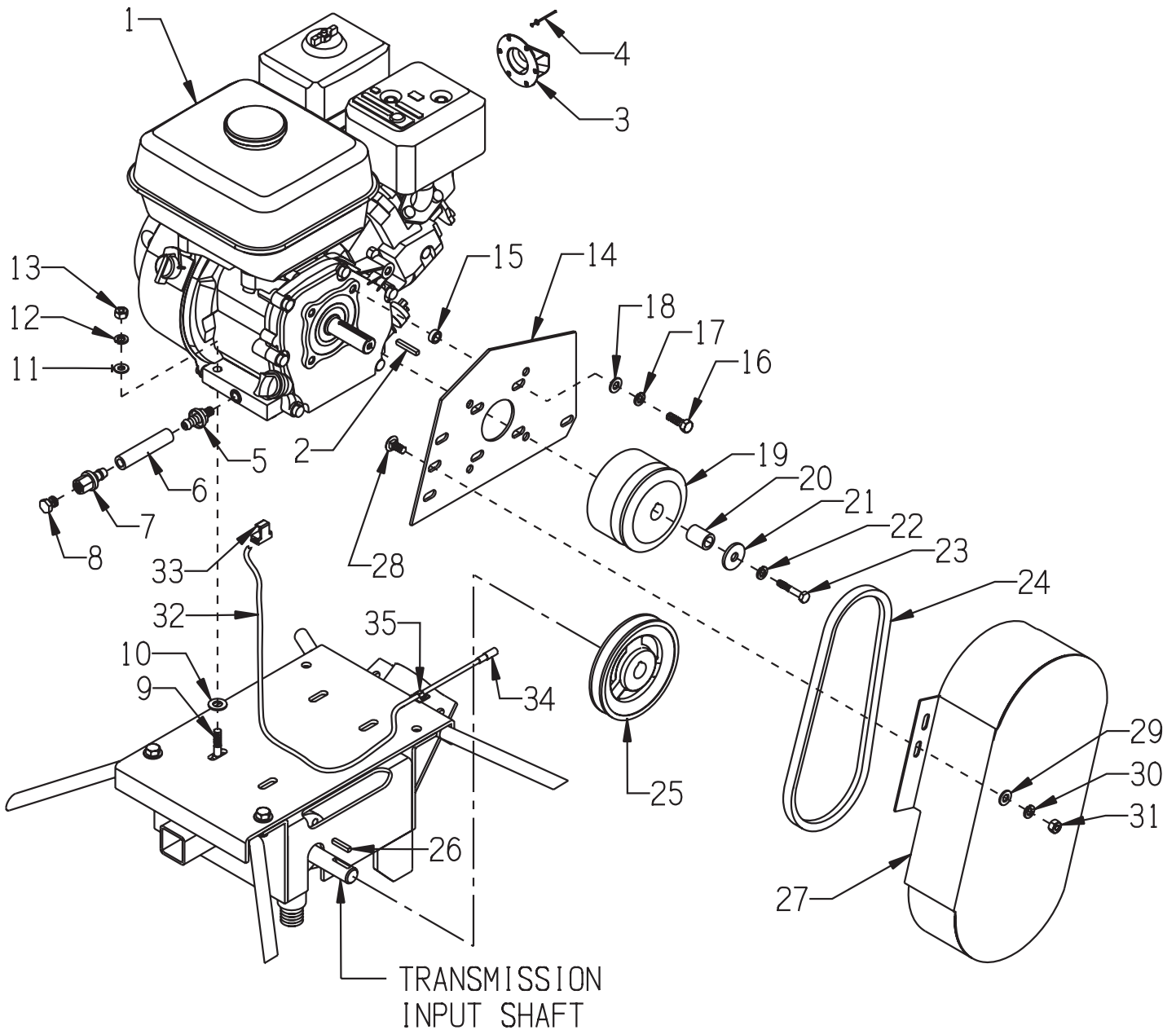

**PARTS LISTING - ILLUSTRATION 13 :
ENGINE GROUPING FOR HONDA GX120 & GX160**

ITEM #	PART #	DESCRIPTION	QTY.
1	15052 15051	HONDA GASOLINE ENGINE W/ DUAL ELEMENT AIR CLEANER MODEL GX120-QX2, 118 CC MODEL GX160UT1-QX2, 163 CC	1
2	65254	KEY 3/16 SQ X 7/8	1
3	10625	MUFFLER CAP, HONDA #18331-ZE3-811	1
4	10128	RIVET, BLIND 1/8 X .250L X .262HD	2
5	11541	BARB, PUSH-ON 3/8 HOSE X10MM X 1.25	1
6	56116	HOSE, PUSH-ON 3/8"ID X 3"L	1
7	11544	BARB, PUSH-ON 3/8 HOSE X 1/4FPT	1
8	10776	PIPE PLUG 1/4 NPT (BRASS)	1
9	10918	BOLT, CARRIAGE 5/16-18 X 1-3/4 F.T.	4
10	10025	WASHER, FLAT 3/8 SAE	4
11	10213	WASHER, FLAT 5/16 SAE	4
12	10801	WASHER, LOCK 5/16	4
13	10054	NUT 5/16-18	4
14	36099	BELT COVER MTG BRACKET, GAS TROWEL	1
15	10113	SPACER, STEEL 9/16OD X 3/8ID X 7/32	4
16	10332	SCREW, CAP 5/16-24 X 1	4
17	10801	WASHER, LOCK 5/16	4
18	10213	WASHER, FLAT 5/16 SAE	4
19	36121	CLUTCH, CENTRIFUGAL 4.00 X 3/4"BORE	1
20	36122	SPACER, CLUTCH OUTER 3/4"OD x 1/2"ID x 1"THK	1
21	72006	WASHER, 1-1/4OD X 13/32ID X 1/8THK	1
22	10801	WASHER, LOCK 5/16	1
23	36123	SCREW, CAP 5/16-24 X 1-3/4	1
24	10252	BELT A-26	1
25	36120	SHEAVE 4.8"OD X 1GR.A X 3/4"BORE	1
26	36108	TRANS. INPUT KEY 3/16SQ X 1 (INCLUDED W/ TRANSMISSION)	1
27	36072	COVER, BELT	1
28	10818	BOLT, CARRIAGE 5/16-18 X 3/4 F.T.	3
29	10801	WASHER, LOCK 5/16	3
30	10213	WASHER, FLAT 5/16 SAE	3
31	10054	NUT 5/16-18	3
32	36047	WIRE, SAFETY SWITCH	1
33	10970	CONN., WIRE QUICK-SPLICE 18-14 GA.	1
34	11567	CONNECTOR, BULLET STD. 16-14GA.BLUE	1
35	36042	CLIP, NATURAL CORD, 1/8" X 1/4"	2



A Division of Equipment Development Company, Inc.

100 Thomas Johnson Drive, Frederick, MD 21702-4600 USA

Phone (301) 663-1600 • 1-800-638-3326

Fax (301) 663-1607 • 1-800-447-3326

Website: www.edcoinc.com

Email: sales@edcoinc.com

Printed in USA

JWA ©2010

Page 19

ILLUSTRATION 14:
ENGINE GROUPING FOR HONDA GX270

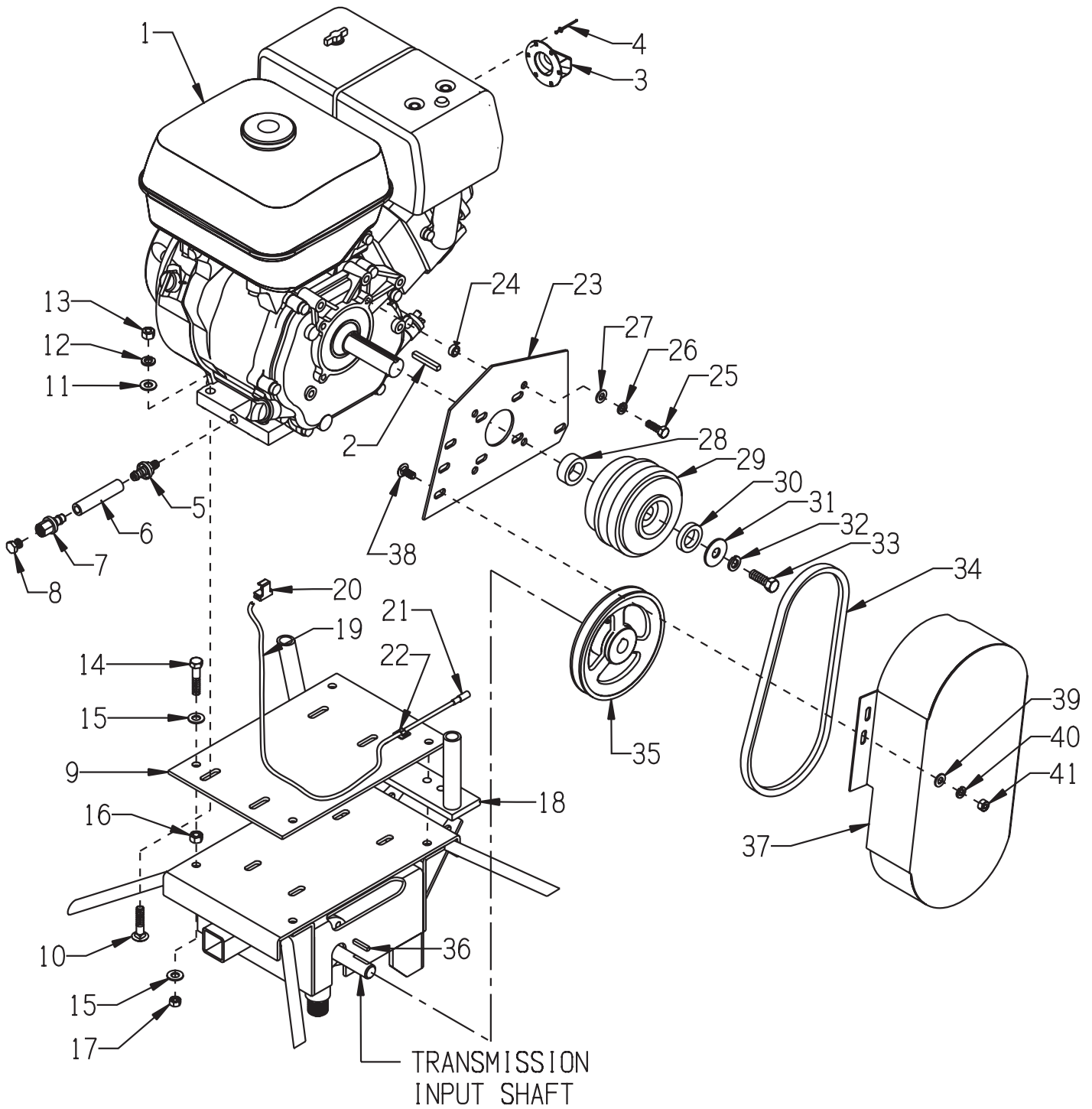

PARTS LISTING - ILLUSTRATION 14 : ENGINE GROUPING FOR HONDA GX270			
ITEM #	PART #	DESCRIPTION	QTY.
1	15053	ENGINE, HONDA GX270UT-QA2 D.E.A.C.	1
2	-----	KEY 1/4SQ. (INCLUDED W/ ENGINE)	1
3	10625	MUFFLER CAP, HONDA #18331-ZE3-811	1
4	10128	RIVET, BLIND 1/8 X .250L X .262HD	2
5	11542	BARB, PUSH-ON 3/8HOSE X 12MM X 1.50	1
6	56116	HOSE, PUSH-ON 3/8"ID X 3"L	1
7	11544	BARB, PUSH-ON 3/8 HOSE X 1/4FPT	1
8	10776	PIPE PLUG 1/4 NPT (BRASS)	1
9	36088	MOUNT, HONDA GX270 ENGINE	1
10	10087	BOLT, CARRIAGE 3/8-16 X 1-3/4 F.T.	4
11	10025	WASHER, FLAT 3/8 SAE	4
12	10811	WASHER, LOCK 3/8	4
13	10404	NUT 3/8-16	4
14	10029	SCREW, CAP 3/8-24 X 1-3/4	4
15	10025	WASHER, FLAT 3/8 SAE	8
16	10014	NUT 3/8-24	2
17	10004	NUT, LOCK 3/8-24	4
18	36098	BAIL, LIFTING, GASOLINE TROWEL (REFER TO ILLUS. 12)	1
19	36047	WIRE, SAFETY SWITCH	1
20	10970	CONN., WIRE QUICK-SPLICE 18-14 GA.	1
21	11567	CONNECTOR, BULLET STD. 16-14GA.BLUE	1
22	36042	CLIP, NATURAL CORD, 1/8" X 1/4"	2
23	36099	BELT COVER MTG BRACKET, GAS TROWEL	1
24	10011	SPACER, STEEL 5/8OD X 3/8ID X 3/8T	4
25	10048	SCREW, CAP 5/16-24 X 3/4	4
26	10801	WASHER, LOCK 5/16	4
27	10213	WASHER, FLAT 5/16 SAE	4
28	36048	SPACER, CLUTCH INNER 1-1/2"OD x 1"ID x 9/16"THK	1
29	36002	CLUTCH, CENTRIFUGAL 4.75 X 1"BORE	1
30	36049	SPACER, CLUTCH OUTER 1-1/2"OD x 1"ID x 5/16"THK	1
31	10433	WASHER, BELLEVILLE 1/2ID X 3/32THK	1
32	10450	WASHER, LOCK 7/16	1
33	10003	SCREW, CAP 7/16-20 X 1-1/4	1
34	10239	BELT AP-32	1
35	36013	SHEAVE 6"OD X 1GR.A X 3/4"BORE	1
36	36108	TRANS. INPUT KEY 3/16SQ X 1 (INCLUDED W/ TRANSMISSION)	1
37	36072	COVER, BELT	1
38	10818	BOLT, CARRIAGE 5/16-18 X 3/4 F.T.	3
39	10801	WASHER, LOCK 5/16	3
40	10213	WASHER, FLAT 5/16 SAE	3
41	10054	NUT 5/16-18	3



A Division of Equipment Development Company, Inc.

100 Thomas Johnson Drive, Frederick, MD 21702-4600 USA

Phone (301) 663-1600 • 1-800-638-3326

Fax (301) 663-1607 • 1-800-447-3326

Website: www.edcoinc.com

Email: sales@edcoinc.com

Printed in USA

JWA ©2010

Page 21

ILLUSTRATION 15: WIRING DIAGRAM

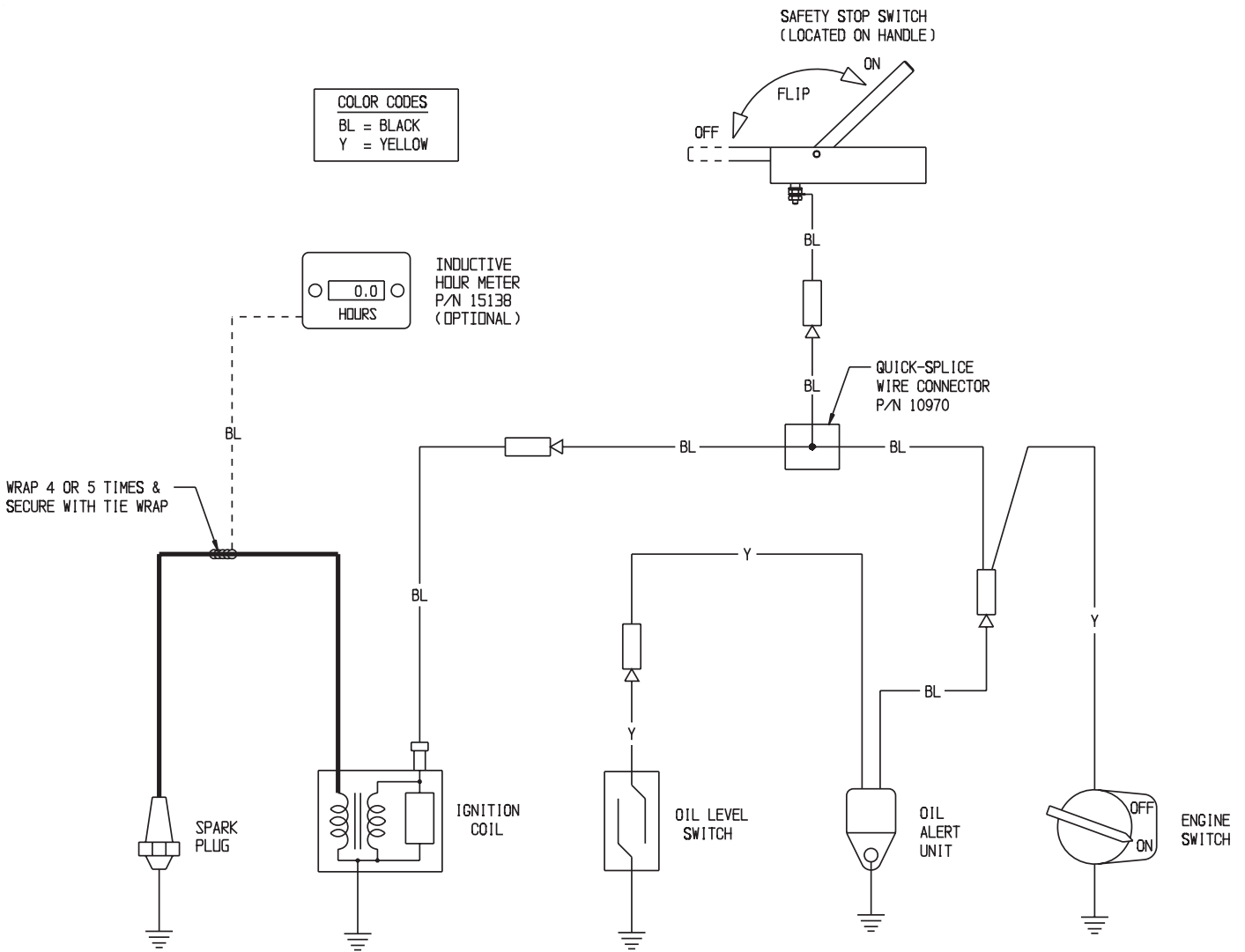
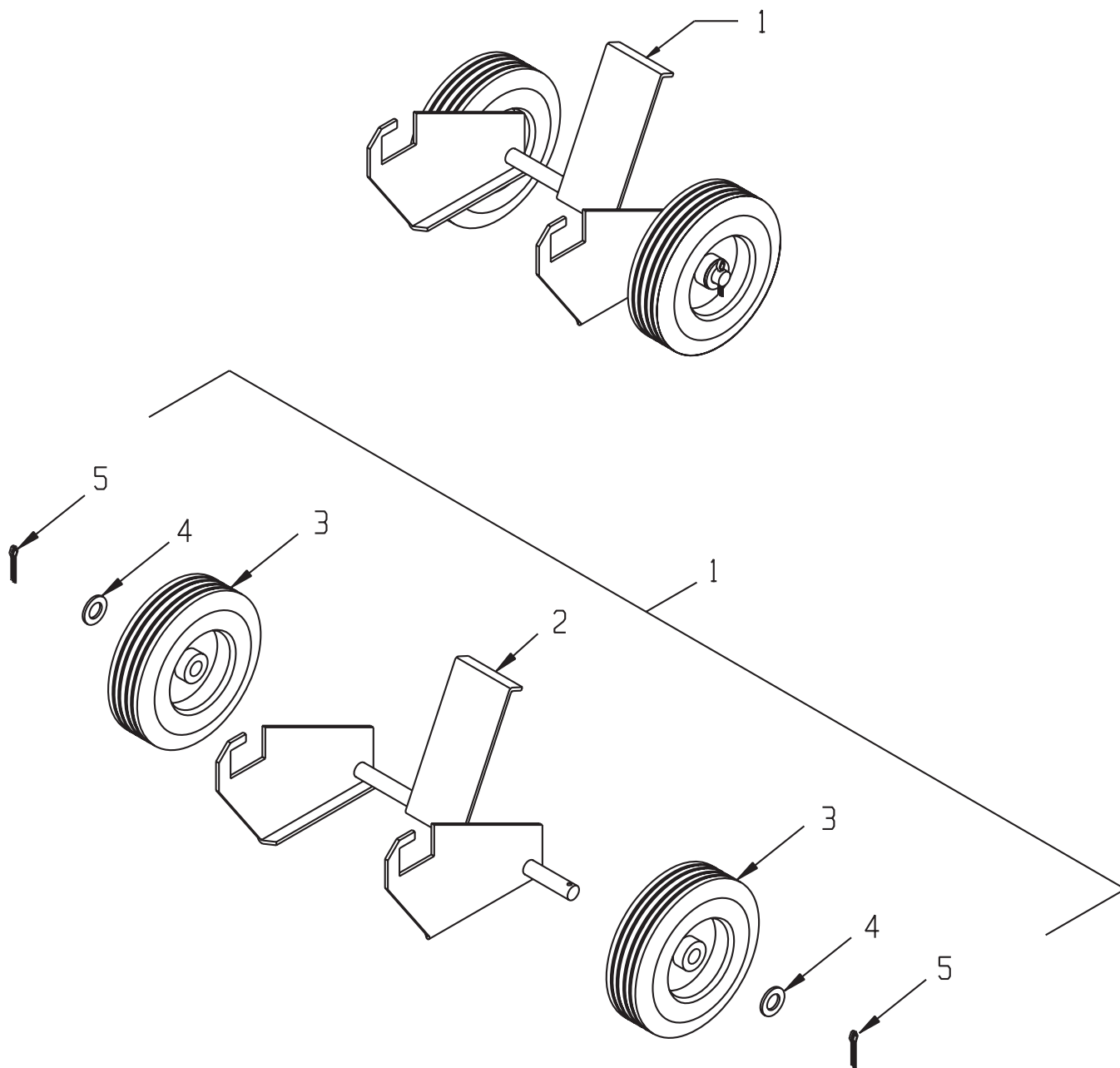

ILLUSTRATION 16: OPTIONAL "TOTE-A-TROWEL"



ITEM #	PART #	DESCRIPTION	QTY.
1	81400	TAT-II "TOTE-A-TROWEL" TRANSPORTER (INCLUDES ITEMS 2 THRU 5)	1
2	81401	FRAME	1
3	79013	WHEEL, 8 X 2-1/2 X 3/4" BRG. POLY HUB	2
4	10009	WASHER, FLAT 3/4 SAE	2
5	10306	PIN, COTTER 3/16 X 1-1/2	2



100 Thomas Johnson Drive, Frederick, MD 21702-4600 USA
 Phone (301) 663-1600 • 1-800-638-3326
 Fax (301) 663-1607 • 1-800-447-3326
 Website: www.edcoinc.com
 Email: sales@edcoinc.com

LIMITED EQUIPMENT WARRANTY OF SALE – TERMS & CONDITIONS

Equipment Development Company, Inc. herein referred to as EDCO (Seller) warrants that each new unit manufactured by EDCO to be free from defects in material and workmanship in normal use and service for a period of (1) one year (except for the cutter drum assembly on all model concrete/asphalt planes, in which case the warranty period shall be 90 days) from date of shipment to the original retail or equipment rental center owner.

Accessories or equipment furnished and installed on the product by EDCO but manufactured by others, including, but not limited to engines, motors, electrical components, transmissions etc., shall carry the accessory manufacturers own warranty.

EDCO will, at its option, repair or replace, at the EDCO factory or at a point designated by EDCO, any part which shall appear to the satisfaction of EDCO inspection to have been defective in material or workmanship.

EDCO reserves the right to modify, alter and improve any part or parts without incurring any obligation to replace any part or parts previously sold without such modified, altered or improved part or parts.

This warranty is in lieu of and excludes all other warranties, expressed, implied, statutory, or otherwise created under applicable law including, but not limited to the warranty of merchantability and the warranty of fitness for a particular purpose in no event shall seller or the manufacturer of the product be liable for special, incidental, or consequential damages, including loss of profits, whether or not caused by or resulting from the negligence of seller and/or the manufacturer of the product unless specifically provided herein. In addition, this warranty shall not apply to any products or portions thereof which have been subjected to abuse, misuse, improper installation, maintenance, or operation, electrical failure or abnormal conditions and to products which have been tampered with, altered, modified, repaired, reworked by anyone not approved by seller or used in any manner inconsistent with the provisions of the above or any instructions or specifications provided with or for the product

FORCE MAJEURE

Seller's obligation hereunder are subject to, and Seller shall not be held responsible for, any delay or failure to make delivery of all or any part of the Product due to labor difficulties, fires, casualties, accidents, acts of the elements, acts of God, transportation difficulties, delays by a common carrier, inability to obtain Product, materials or components or qualified labor sufficient to timely perform part of or all of the obligations contained in these terms and conditions, governmental regulations or actions, strikes, damage to or destruction in whole or part of manufacturing plant, riots, terrorist attacks or incidents, civil commotions, warlike conditions, flood, tidal waves, typhoon, hurricane, earthquake, lightning, explosion or any other causes, contingencies or circumstances within or without the United States not subject to the Seller's control which prevent or hinder the manufacture or delivery of the Products or make the fulfillment of these terms and conditions impracticable. In the event of the occurrence of any of the foregoing, at the option of Seller, Seller shall be excused from the performance under these Terms and Conditions, or the performance of the Seller shall be correspondingly extended.

This document sets forth the terms and conditions pursuant to which the purchaser ("Purchaser") will purchase and Equipment Development Co. Inc. ("Seller") will sell the products, accessories, attachments (collectively the Products) ordered by the Purchaser. These terms and conditions shall govern and apply to the sale of Seller's Products to Purchaser, regardless of any terms and conditions appearing on any purchase order or other forms submitted by Purchaser to Seller, or the inconsistency of any terms therein and herein.

1. PRICE

All prices set forth on any purchase order or other document are F.O.B. Sellers facility or distribution point, as may be determined by Seller (F.O.B. Point). All prices are exclusive of any and all taxes, including, but not limited to, excise, sales, use, property or transportation taxes related to the sale or use of the Products, now or hereafter imposed, together with all penalties and expenses. Purchaser shall be responsible for collecting and/or paying any and all such taxes, whether or not they are stated in any invoice for the Products. Unless otherwise specified herein, all prices are exclusive of inland transportation, freight, insurance and other costs and expenses relating to the shipment of the Products from the F.O.B. point to Purchaser's facility. Any prepayment by Seller of freight insurance and other costs shall be for the account of Purchaser and shall be repaid to Seller.

2. PAYMENT TERMS

Payment terms are as follows. 2% 10 days (to approved and qualified accounts). Net 30 days. This is a cash discount for invoices paid within 10 days after the invoice date, regardless of date of receipt of shipment. This is not a trade discount and will not be granted to accounts that do not adhere to stated terms.

*All past due accounts are subject to a late payment fee of 1.5% per month or a maximum allowed by law if different, along with the expenses incidental to collection including reasonable attorney's fees and costs.

*Seller reserves the right to hold shipments against past due accounts.

*Seller reserves the right to alter payment terms.

3. FREIGHT TERMS

All shipments will be made F.O.B. shipping point as designated in these Terms and Conditions, and title shall pass at the F.O.B. point. Delivery to the initial common carrier shall constitute delivery to the Purchaser. Any claims for loss or damage during shipment are to be filed with carrier by the Purchaser. Seller will not assume responsibility for the performance of the carrier.

Back orders will be shipped in the most practical fashion with charges consistent with our freight policy established with the original order. UPS, FED EX, MAIL or shipments by third couriers are subject to the same terms and conditions as outlined in paragraph #3 "Freight Terms".

4. DELIVERY, DAMAGES, SHORTAGES

Seller shall use reasonable efforts to attempt to cause the Products to be delivered as provided for in these Terms & Conditions. Delivery to the initial common carrier shall constitute the delivery to the Purchaser. Seller's responsibility, in so far as transportation risks are concerned ceases upon the delivery of the Products in good condition to such carrier at the F.O.B. point and all the Products shall be shipped at the Purchaser's risk. Seller shall not be responsible or liable for any loss of income and/or profits, or incidental, special, consequential damages resulting from Seller's delayed performance in shipment and delivery.

5. RETURN OF DEFECTIVE PRODUCTS

Defective or failed material shall be held at the Purchaser's premises until authorization has been granted by Seller to return or dispose of Products. Products that are to be returned for final inspection must be returned Freight Prepaid in the most economical way. Credit will be issued for material found to be defective upon Seller's inspection based on prices at time of purchase.

6. PRODUCTS ORDERED IN ERROR

Products may be returned, provided that claim is made and Seller is notified within 7 days of receipt of Products, and the Products are in original buyer's possession not more than 30 days prior to return, subject to Seller's approval. If Products are accepted for return, they must be Freight Prepaid and buyer will be charged a minimum of 15% restocking charge, plus a charge back for outbound freight charges if the original order was shipped prepaid. Returns are not accepted for any Products that are specifically manufactured to meet the buyer's requirement of either specifications or quantity.

AGREEMENTS

These Terms and Conditions constitute the entire agreement between Seller and Purchaser as it relates to terms and conditions of sale, and supersedes any and all prior oral or written agreements, correspondence, quotations or understandings heretofore in force between the parties relating to the subject matter hereof. There are no agreements between Seller and Purchaser with respect to the Product herein except those specifically set forth in and made part of these terms and conditions. Any additional terms, conditions and/or prices are rejected by Seller.

These terms and conditions may be modified, cancelled or rescinded only by a written agreement of both parties executed by their duly authorized agents.

**USE ONLY GENUINE EDCO PARTS & ACCESSORIES
For your own safety, the safety of others and the life of your machine.**

Equipment Development Company, Inc.

