

STARTING SERIAL #071010186

ELECTRIC POWERED 14" MASONRY SAW PARTS LIST MANUAL



MODEL SDE14
SKU# 28100



A Division of Equipment Development Company, Inc.

100 Thomas Johnson Drive, Frederick, MD 21702-4600 USA
Phone (301) 663-1600 • 1-800-638-3326
Fax (301) 663-1607 • 1-800-447-3326
Website: www.edcoinc.com
Email: sales@edcoinc.com

Printed in USA

©2007

READ AND UNDERSTAND THE OPERATORS INSTRUCTION MANUAL THOROUGHLY BEFORE ATTEMPTING TO OPERATE THIS EQUIPMENT. Death or serious injury could occur if this machine is used improperly.



SAFETY MESSAGES



The safety instructions are preceded by a graphic alert message of DANGER, WARNING, or CAUTION.



Indicates an imminent hazard which, if not avoided, will result in death or serious injury.



Indicates an imminent hazard which, if not avoided, can result in death or serious injury.



Indicates hazards which, if not avoided, could result in serious injury and or damage to the equipment.

GASOLINE Powered Equipment



- Do not operate gasoline powered equipment without adequate ventilation. Carbon monoxide is an invisible, odorless gas that can kill.

ELECTRICAL Powered Equipment



- ELECTRICAL HAZARD** - Be sure equipment is properly grounded. Failure to comply could kill or result in serious injury.



The engine exhaust from this product contains chemicals known to the State of California to cause cancer, birth defects or other reproductive harm.

GENERAL INSTRUCTIONS



- You must read and understand the operators instruction manual and all other manuals associated with this machine. For your safety and the safety of others around you, it is extremely important to fully understand how to operate this machine in the way it was intended. Different model machines or older/newer versions of the same model may have different parts and controls that you need to understand. If instructions are not readable or available DO NOT USE this machine and contact the factory for a replacement Manual.
- You must be able to physically handle the bulk weight and power of this machine. If not properly controlled this machine can cause death or serious injury.
- Do not operate this machine in an impaired mental state. You must be able to exercise good judgement and reactions to maintain a safe working environment.
- This is a "one person" machine which means only one operator can be operating the machine at any one time. For the safety of others, maintain a safe operating distance to other personnel. Your work area should be defined and appropriately marked so bystanders and coworkers do not stand or walk near this machine and end up seriously injured by flying debris or exposing them to harmful noise or dust.
- This equipment is for Commercial use. Although this is a "one person" machine your work team should understand how to shut this machine off and quickly get medical help if an accident strikes the operator.
- Keep all guards in place during operation. The guards are to provide protection from inadvertent contact with dangerous moving parts, pinch points, or hot surfaces.
- Wear appropriate Personal Protective Equipment (PPE) including safety glasses, safety boots, work gloves, respiratory protection, hearing protection, and head protection. Do not wear loose clothing that can get tangled in moving parts. Failure to do so could result

in dismemberment or death. **Wear an approved respirator when removing hazardous materials or when grinding/cutting dry materials. Some dust particles such as concrete dust can contain silicate particles which can cause silicosis (a very serious lung disease). Contact NIOSH or OSHA for further details. When wet grinding/cutting, avoid contact with the concrete/asphalt slurry which can cause serious skin irritations.**

- You must maintain this machine per the maintenance schedule in the operator manual. Remember before adjusting, servicing, or fueling this machine, disconnect the source of power to the machine by disconnecting the spark plug (Gas models), or by unplugging the electrical power cord (electric models) or air hose (Pneumatic models) AT THE MACHINE so you can assure yourself it remains unplugged while you are working on it. Do not modify this machine. Use only genuine EDCO parts and accessories. Repairs and service should be performed by approved EDCO dealers or authorized technicians.
- You should look carefully around the area before you begin work so you can identify potential hazards such as deck inserts, pipes, columns, openings, electrical cords or outlets, or any other objects protruding from the slab surface.
- This machine has no brain so you must use your own. There is no substitute for safety. The safety decals on the machine are to serve as a reminder for information you must already know before you begin using this machine. Take a moment to reread the safety decals each time you use the machine. If your machine is missing any decals, contact the factory for a replacement (EDCO 1-800-638-3326).

PARTS LIST MANUAL

MODEL SDE14

<u>Section</u>	<u>Page Number</u>
Safety Messages and General Instructions	2
How To Order Replacement Parts.	3
Illustration 1 : Main Grouping	4,5
Illustration 2 : Motor Grouping	6,7
Limited Equipment Warranty	Back Page

<p style="text-align: center;">HOW TO ORDER REPLACEMENT PARTS</p> <ul style="list-style-type: none"> <input type="checkbox"/> To insure product safety and reliability, always use genuine EDCO replacement parts when making repairs to the equipment. <input type="checkbox"/> When calling for parts, specify the MODEL and SERIAL number of the machine, which can be found on the NAME PLATE. Keep that information in the space provided. In addition to this information, give part number, description, and quantity as listed on the parts list to your parts representative. <input type="checkbox"/> Please note: Due to improvements and changes in the equipment, the illustrations shown may be different than the actual machine. 	<p style="text-align: center;">FILL IN INFORMATION BELOW</p> <p>Date of Purchase _____</p> <p>Model # _____</p> <p>Serial # _____</p> <p>SKU # _____</p>
--	---

ILLUSTRATION 1 : MAIN GROUPING

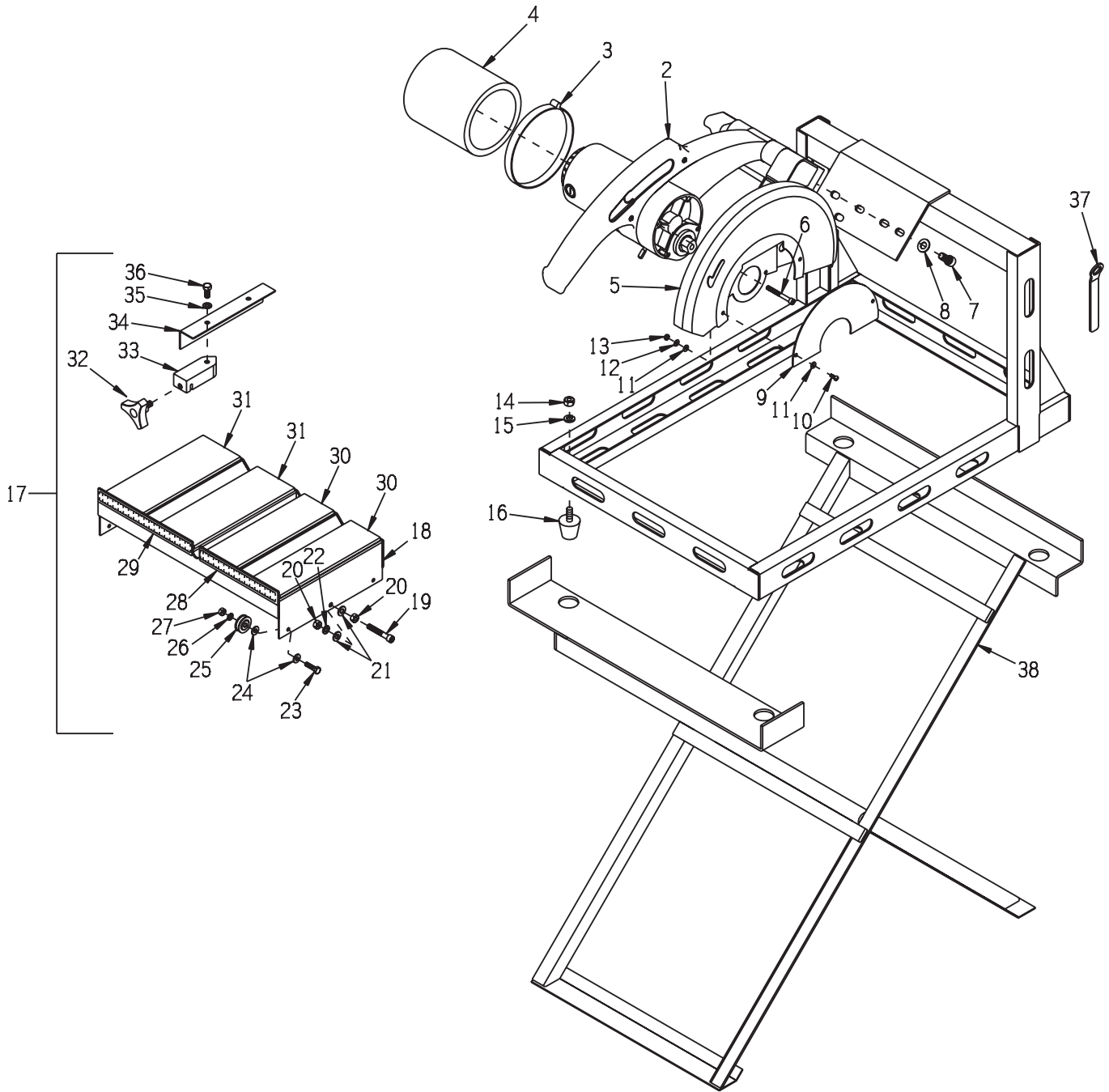

ILLUSTRATION 1 : MAIN GROUPING			
ITEM #	PART #	DESCRIPTION	QTY.
1	36812	MAIN FRAME	1
2	36811	MOTOR & HEAD ASSEMBLY (REFER TO ILLUS. 2 FOR BREAKDOWN)	1
3	36814	CLAMP, HOSE, SAE#80, ADJ. TO 5-1/2	1
4	36810	FILTER, MOTOR	1
5	36815	GUARD, 14" BLADE	1
6	-----	SEE ILLUSTRATION 2, ITEM 47	4
7	-----	SEE ILLUSTRATION 2, ITEM 80	2
8	10062	WASHER, FLAT 7/16 SAE	2
9	36813	PLATE, BLADE GUARD SIDE	2
10	11663	SCREW, MACHINE 8-32x1/2	2
11	10875	WASHER, FLAT #8 SAE	4
12	10461	WASHER, LOCK, INT. TOOTH #8	2
13	10462	NUT 8-32	2
14	10054	NUT 5/16-18	4
15	10801	WASHER, LOCK 5/16	4
16	10931	MOUNT, TAPERED RUBBER 5/16-18	4
17	36802A	TABLE ASSEMBLY, ROLL (INCLUDES ITEMS 18-34)	1
18	36802	TABLE, ROLL	1
19	11685	SCREW, SKT. HD. CAP 5/16-18x2-1/4	2
20	10054	NUT 5/16-18	4
21	10213	WASHER, FLAT 5/16 SAE	4
22	10801	WASHER, LOCK 5/16	2
23	10031	SCREW, CAP 1/4-20x1	4
24	10602	WASHER, FLAT 1/4 SAE	AS REQ'D.
25	14082	PULLEY BEARING 1-1/4x1/4 BORE (TRACK WHEEL)	4
26	10038	WASHER, LOCK 1/4	4
27	10013	NUT 1/4-20	4
28	40424	RULE, ADHESIVE-BACKED, 1-7, L-R	1
29	40423	RULE, ADHESIVE-BACKED, 1-13, R-L	1
30	36821	RUBBER PAD 9-3/4 X 3-5/8 X 3/16	2
31	36822	RUBBER PAD 9-3/4 X 2-7/8 X 3/16	2
32	40425	KNOB, 3-PRONG W/ 3/8-16x5/8 STUD	1
33	42015	BLOCK, CUT GUIDE	1
34	36803	BRACKET, CUT GUIDE	1
35	10801	WASHER, LOCK 5/16	1
36	10053	SCREW, CAP 5/16-18x3/4	1
37	36816	WRENCH 17mm	1
38	36820	STAND, FOLDING (OPTIONAL)	1

ILLUSTRATION 2 : MOTOR GROUPING

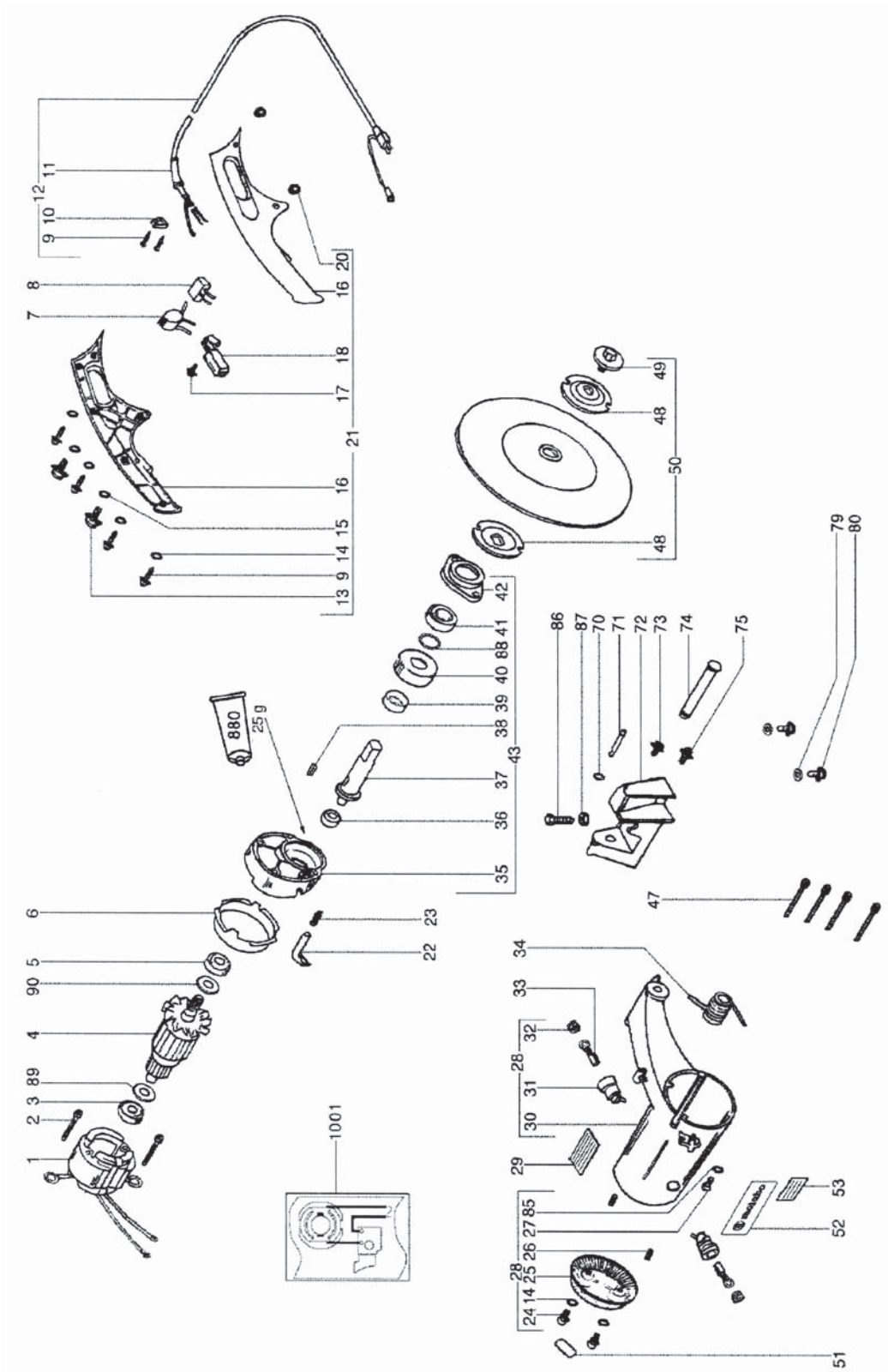

ILLUSTRATION 2 : MOTOR GROUPING			
ITEM #	PART #	DESCRIPTION	QTY.
1	M311010050	FIELD COIL 110V	1
2	M141116820	FILL. HEAD SCREW FORM A	2
3	M143111090	BALL BEARING 10x30x9	1
4	M310008510	ARMATURE CPL. 110V	1
5	M143113330	BALL BEARING 17x35x10	1
6	M339150940	AIR DEFLECTOR	1
7	M399999990	PART NOT NEEDED	1
8	M399999990	PART NOT NEEDED	1
9	M141116800	SELF-TAP FILL. H. SCREW	6
10	M343376450	CABLE CLIP	1
11	M344096130	CABLE SLEEVE	1
12	M344494740	CABLE WITH PLUG	1
13	M141116770	FILLISTER HEAD SCREW	2
14	M141151860	WASHER	6
15	M141150020	WASHER	2
16	M316038750	HANDLE	1
17	M341703270	SCREW	1
18	M343407100	SWITCH	1
20	M141130090	HEXAGONAL NUT	2
21	M316032320	HANDLE CPL.	1
22	M341514820	SPINDLE STOP	1
23	M342002920	SPRING	1
24	M141119860	FILLISTER HEAD SCREW	2
25	M315415530	MOTOR HOUSING COVER	1
26	M141116480	GRUB SCREW	2
27	M141110600	FILLISTER HEAD SCREW	1
28	M316032290	MOTOR HOUSING	1
29	M338115850	INDICATION LABEL	1
30	M315415540	MOTOR HOUSING	1
31	M343000820	BRUSH HOLDER	2
32	M343030160	COVER CAP FOR BUSHES	2
33	M316033970	CARBON BRUSH	1
34	M342002930	SPRING	1
35	M315104050	GEAR HOUSING	1
36	M143113880	BALL BEARING 10x26x8	1
37	M341160850	SPINDLE	1
38	M341147370	KEY	1
39	M341005210	RING	1
40	M340032630	GEAR WHEEL	1
41	M143112280	BALL BEARING 20x42x12	1
42	M315415450	GEAR BOX COVER	1
43	M316032330	GEAR BOX CPL.	1
47	M141113950	CAP SCREW	4
48	M339006610	SUPPORTING DISC	2
49	M341703210	FASTENING SCREW	1
50	M316032300	FLANGE ASSEMBLY	1
51	M338040460	RATING LABEL	1
52	M338115510	METABO LABEL	1
53	M338115890	INDICATION LABEL	1
70	M344095940	O-RING	1
71	M341514830	LOCKING BOLT	1
72	M315415460	HOLDER FOR MOTOR HOUSING	1
73	M341703290	FILLISTER HEAD SCREW	1
74	M341514810	BOLT	1
75	M341703300	FILLISTER HEAD SCREW	1
79	M141150670	SPRING RING	2
80	M141114130	CHEESE HEAD SCREW	2
84	M316032340	BASE PLATE CPL.	1
85	M141150420	SERRATED LOCK WASHER	1
86	M141113430	HEXAGON HEAD SCREW	1
87	M141130130	HEXAGONAL NUT	1
88	M344096380	O-RING	1
89	M339006630	SUPPORTING DISC	1
90	M339006640	SUPPORTING DISC	1
880	M344130950	GREASE	1
1001	XXXXXXXXXX	DIAGRAM	1

LIMITED EQUIPMENT WARRANTY OF SALE – TERMS & CONDITIONS

Equipment Development Company, Inc. herein referred to as EDCO (Seller) warrants that each new unit manufactured by EDCO to be free from defects in material and workmanship in normal use and service for a period of (1) one year (except for the electric motor, in which case the warranty period shall be 90 days) from date of shipment to the original retail or equipment rental center owner.

Accessories or equipment furnished and installed on the product by EDCO but manufactured by others, including, but not limited to engines, motors, electrical components, transmissions etc., shall carry the accessory manufacturers own warranty.

EDCO will, at its option, repair or replace, at the EDCO factory or at a point designated by EDCO, any part which shall appear to the satisfaction of EDCO inspection to have been defective in material or workmanship.

EDCO reserves the right to modify, alter and improve any part or parts without incurring any obligation to replace any part or parts previously sold without such modified, altered or improved part or parts.

This warranty is in lieu of and excludes all other warranties, expressed, implied, statutory, or otherwise created under applicable law including, but not limited to the warranty of merchantability and the warranty of fitness for a particular purpose in no event shall seller or the manufacturer of the product be liable for special, incidental, or consequential damages, including loss of profits, whether or not caused by or resulting from the negligence of seller and/or the manufacturer of the product unless specifically provided herein. In addition, this warranty shall not apply to any products or portions there of which have been subjected to abuse, misuse, improper installation, maintenance, or operation, electrical failure or abnormal conditions and to products which have been tampered with, altered, modified, repaired, reworked by anyone not approved by seller or used in any manner inconsistent with the provisions of the above or any instructions or specifications provided with or for the product

FORCE MAJEURE

Seller's obligation hereunder are subject to, and Seller shall not be held responsible for, any delay or failure to make delivery of all or any part of the Product due to labor difficulties, fires, casualties, accidents, acts of the elements, acts of God, transportation difficulties, delays by a common carrier, inability to obtain Product, materials or components or qualified labor sufficient to timely perform part of or all of the obligations contained in these terms and conditions, governmental regulations or actions, strikes, damage to or destruction in whole or part of manufacturing plant, riots, terrorist attacks or incidents, civil commotions, warlike conditions, flood, tidal waves, typhoon, hurricane, earthquake, lightning, explosion or any other causes, contingencies or circumstances within or without the United States not subject to the Seller's control which prevent or hinder the manufacture or delivery of the Products or make the fulfillment of these terms and conditions impracticable. In the event of the occurrence of any of the foregoing, at the option of Seller, Seller shall be excused from the performance under these Terms and Conditions, or the performance of the Seller shall be correspondingly extended.

This document sets forth the terms and conditions pursuant to which the purchaser ("Purchaser") will purchase and Equipment Development Co.Inc. ("Seller") will sell the products, accessories, attachments (collectively the Products ") ordered by the Purchaser. These terms and conditions shall govern and apply to the sale of Seller's Products to Purchaser, regardless of any terms and conditions appearing on any purchase order or other forms submitted by Purchaser to Seller, or the inconsistency of any terms therein and herein.

1. PRICE

All prices set forth on any purchase order or other document are F.O.B. Sellers facility or distribution point, as may be determined by Seller (F.O.B.Point). All prices are exclusive of any and all taxes, including, but not limited to, excise, sales, use, property or transportation taxes related to the sale or use of the Products, now or hereafter imposed, together with all penalties and expenses. Purchaser shall be responsible for collecting and/or paying any and all such taxes, whether or not they are stated in any invoice for the Products. Unless otherwise specified herein, all prices are exclusive of inland transportation, freight, insurance and other costs and expenses relating to the shipment of the Products from the F.O.B. point to Purchaser's facility. Any prepayment by Seller of freight insurance and other costs shall be for the account of Purchaser and shall be repaid to Seller.

2. PAYMENT TERMS

Payment terms are as follows. 2% 10 days (to approved and qualified accounts). Net 30 days. This is a cash discount for invoices paid within 10 days after the invoice date, regardless of date of receipt of shipment. This is not a trade discount and will not be granted to accounts that do not adhere to stated terms.

*All past due accounts are subject to a late payment fee of 1.5% per month or a maximum allowed by law if different, along with the expenses incidental to collection including reasonable attorney's fees and costs.

*Seller reserves the right to hold shipments against past due accounts.

*Seller reserves the right to alter payment terms.

3. FREIGHT TERMS

All shipments will be made F.O.B. shipping point as designated in these Terms and Conditions, and title shall pass at the F.O.B. point. Delivery to the initial common carrier shall constitute delivery to the Purchaser. Any claims for loss or damage during shipment are to be filed with carrier by the Purchaser. Seller will not assume responsibility for the performance of the carrier.

Back orders will be shipped in the most practical fashion with charges consistent with our freight policy established with the original order. UPS, FED EX, MAIL or shipments by other couriers are subject to the same terms and conditions as outlined in paragraph #3"Freight Terms".

4. DELIVERY, DAMAGES, SHORTAGES

Seller shall use reasonable efforts to attempt to cause the Products to be delivered as provided for in these Terms & Conditions. Delivery to the initial common carrier shall constitute the delivery to the Purchaser. Sellers responsibility, in so far as transportation risks are concerned ceases upon the delivery of the Products in good condition to such carrier at the F.O.B. point and all the Products shall be shipped at the Purchaser's risk. Seller shall not be responsible or liable for any loss of income and/or profits, or incidental, special, consequential damages resulting from Seller's delayed performance in shipment and delivery.

5. RETURN OF DEFECTIVE PRODUCTS

Defective or failed material shall be held at the Purchaser's premises until authorization has been granted by Seller to return or dispose of Products. Products that are to be returned for final inspection must be returned Freight Prepaid in the most economical way. Credit will be issued for material found to be defective upon Seller's inspection based on prices at time of purchase.

6. PRODUCTS ORDERED IN ERROR

Products may be returned, provided that claim is made and Seller is notified within 7 days of receipt of Products, and the Products are in original buyer's possession not more than 30 days prior to return, subject to Seller's approval. If Products are accepted for return, they must be Freight Prepaid and buyer will be charged a minimum of 15% rehandling charge, plus a charge back for outbound freight charges if the original order was shipped prepaid. Returns are not accepted for any Products that are specifically manufactured to meet the buyer's requirement of either specifications or quantity.

AGREEMENTS

These Terms and Conditions constitute the entire agreement between Seller and Purchaser as it relates to terms and conditions of sale, and supersedes any and all prior oral or written agreements, correspondence, quotations or understandings heretofore in force between the parties relating to the subject matter hereof. There are no agreements between Seller and Purchaser with respect to the Product herein except those specifically set forth in and made part of these terms and conditions. Any additional terms, conditions and/or prices are rejected by Seller.

These terms and conditions may be modified, cancelled or rescinded only by a written agreement of both parties executed by their duly authorized agents.

USE ONLY GENUINE EDCO PARTS & ACCESSORIES
For your own safety, the safety of others and the life of your machine.