

ELECTRIC POWER TROWEL

PARTS LIST MANUAL



24", 30", 36", and 46" Models



100 Thomas Johnson Drive, Frederick, MD 21702-4600 USA
Phone (301) 663-1600 • 1-800-638-3326
Fax (301) 663-1607 • 1-800-447-3326
Website: www.edcoinc.com • Email: sales@edcoinc.com

Printed in USA
©2005

READ AND UNDERSTAND THE OPERATORS INSTRUCTION MANUAL THOROUGHLY BEFORE ATTEMPTING TO OPERATE THIS EQUIPMENT. Death or serious injury could occur if this machine is used improperly.



SAFETY MESSAGES



The safety instructions are preceded by a graphic alert message of DANGER, WARNING, or CAUTION.



Indicates an imminent hazard which, if not avoided, will result in death or serious injury.



Indicates an imminent hazard which, if not avoided, can result in death or serious injury.



Indicates hazards which, if not avoided, could result in serious injury and or damage to the equipment.

GASOLINE Powered Equipment



- Do not operate gasoline powered equipment without adequate ventilation. Carbon monoxide is an invisible, odorless gas that can kill.

ELECTRICAL Powered Equipment



- ELECTRICAL HAZARD** - Be sure equipment is properly grounded. Failure to comply could kill or result in serious injury.



The engine exhaust from this product contains chemicals known to the State of California to cause cancer, birth defects or other reproductive harm.

GENERAL INSTRUCTIONS



- You must read and understand the operators instruction manual and all other manuals associated with this machine. For your safety and the safety of others around you, it is extremely important to fully understand how to operate this machine in the way it was intended. Different model machines or older/newer versions of the same model may have different parts and controls that you need to understand. If instructions are not readable or available DO NOT USE this machine and contact the factory for a replacement Manual.
- You must be able to physically handle the bulk weight and power of this machine. If not properly controlled this machine can cause death or serious injury.
- Do not operate this machine in an impaired mental state. You must be able to exercise good judgement and reactions to maintain a safe working environment.
- This is a "one person" machine which means only one operator can be operating the machine at any one time. For the safety of others, maintain a safe operating distance to other personnel. Your work area should be defined and appropriately marked so bystanders and coworkers do not stand or walk near this machine and end up seriously injured by flying debris or exposing them to harmful noise or dust.
- This equipment is for Commercial use. Although this is a "one person" machine your work team should understand how to shut this machine off and quickly get medical help if an accident strikes the operator.
- Keep all guards in place during operation. The guards are to provide protection from inadvertent contact with dangerous moving parts, pinch points, or hot surfaces.
- Wear appropriate Personal Protective Equipment (PPE) including safety glasses, safety boots, work gloves, respiratory protection, hearing protection, and head protection. Do not wear loose clothing that can get tangled in moving parts. Failure to do so could result in dismemberment or death. **Wear an approved respirator when removing hazardous materials or when grinding/cutting dry materials. Some dust particles such as concrete dust can contain silicate particles which can cause silicosis (a very serious lung disease). Contact NIOSH or OSHA for further details. When wet grinding/cutting, avoid contact with the concrete/asphalt slurry which can cause serious skin irritations.**
- You must maintain this machine per the maintenance schedule in the operator manual. Remember before adjusting, servicing, or fueling this machine, disconnect the source of power to the machine by disconnecting the spark plug (Gas models), or by unplugging the electrical power cord (electric models) or air hose (Pneumatic models) AT THE MACHINE so you can assure yourself it remains unplugged while you are working on it. Do not modify this machine. Use only genuine EDCO parts and accessories. Repairs and service should be performed by approved EDCO dealers or authorized technicians.
- You should look carefully around the area before you begin work so you can identify potential hazards such as deck inserts, pipes, columns, openings, electrical cords or outlets, or any other objects protruding from the slab surface.
- This machine has no brain so you must use your own. There is no substitute for safety. The safety decals on the machine are to serve as a reminder for information you must already know before you begin using this machine. Take a moment to reread the safety decals each time you use the machine. If your machine is missing any decals, contact the factory for a replacement (EDCO 1-800-638-3326).

PARTS LIST MANUAL

ELECTRIC POWER TROWEL

Section	Page Number
Safety Messages / General Instructions	2
How To Order Replacement Parts	3
Illustration 1: Handle Bar Assembly Grouping (Standard)	4,5
Illustration 2: Optional Lev-I-it System Grouping	6,7
Illustration 3: Frame Deck W/ Guard Ring & Spider Subassembly Grouping	8,9
Illustration 4: Spider Subassembly & Blade Grouping	10
Illustration 5: Optional 36" Float Pan	11
Power Trowel Blade Chart	11
Illustration 6: 1.5 & 2HP Electric Motor Grouping	12,13
Illustration 7: 3HP Electric Motor Grouping	14,15
Illustration 8: 20:1 Ratio Transmission Assembly Grouping	16
Illustration 9: 40:1 Ratio Transmission Assembly Grouping	17
Illustration 10: Optional TAT II "Tote-a-Trowel"	18
Illustration 11: Optional 110 Volt Lamp Kit Assembly	19
Limited Equipment Warranty	20 (back cover)

ELECTRIC POWER TROWELS				
*PART NO.	MODEL	SIZE	RPM	ELECTRIC MOTOR OPTION
84600	T244-1.5B	24"	100	BALDOR 1.5HP-1 PHASE-60HZ, 115/230V, 14/7 FLA
C86400	T244RS-1.5B	24"	50	
80400	T304-1.5B	30"	100	
C85100	T304RS-1.5B	30"	50	
80800	T364-1.5B	36"	100	
C85200	T364RS-1.5B	36"	50	LEESON 2HP-1 PHASE-60HZ, 115/230V, 18.8/9.4 FLA
81300	T364-2L	36"	100	
C86200	T364RS-2L	36"	50	
81200	T464-3B	46"	100	BALDOR 3HP-1 PHASE-60HZ, 230V, 14.5 FLA
C85300	T464RS-3B	46"	50	

*ADDAN "L" SUFFIX TO ANY PART NO. LISTED FOR POWER TROWELS WITH THE LEV-L-IT SYSTEM. (SEE PAGES 6 & 7)

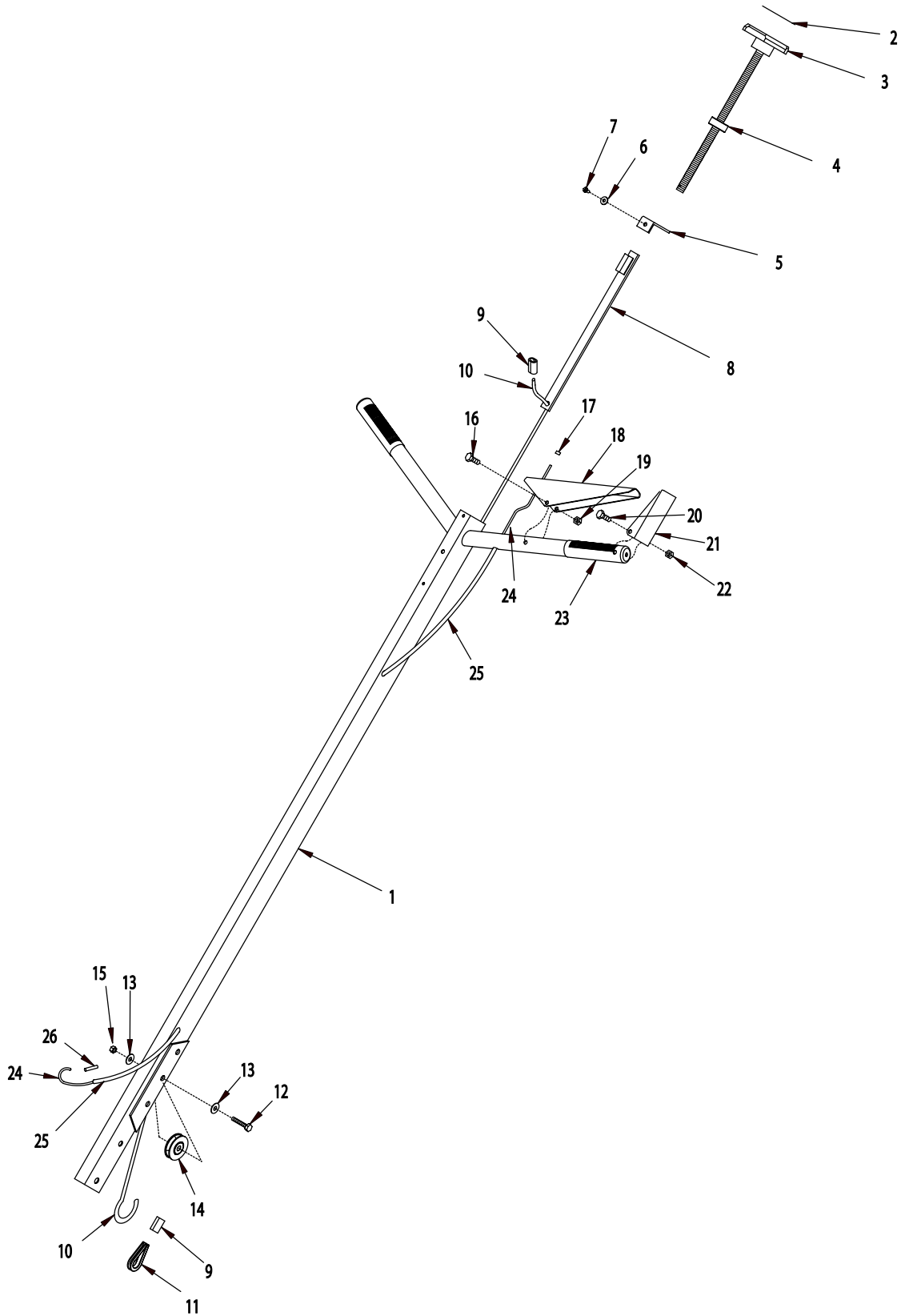
<h3 style="text-align: center;">HOW TO ORDER REPLACEMENT PARTS</h3> <p><input type="checkbox"/> To insure product safety and reliability, always use genuine EDCO replacement parts when making repairs to the equipment.</p> <p><input type="checkbox"/> When calling for parts, specify the MODEL and SERIAL NUMBER of the machine which can be found on the NAME PLATE. Keep that information in the space provided. In addition to this information, give part number, description and quantity as listed on the parts list to your parts representative.</p> <p><input type="checkbox"/> Please note: Due to improvements and changes in the equipment, the illustrations shown may be different than the actual machine.</p>	<h3 style="text-align: center;">FILL IN INFORMATION BELOW</h3> <p>Date of Purchase _____</p> <p>Name of Machine _____</p> <p>Model # _____</p> <p>Serial # _____</p> <p>Belt Size(s) _____</p> <p style="text-align: center;">Toll Free: 1-800-638-3326 FAX: 1-800-447-3326 email: sales@edcoinc.com www.edcoinc.com</p>
------------------------------------------------------------------------------------------------------------------------------------------------------------------------------------------------------------------------------------------------------------------------------------------------------------------------------------------------------------------------------------------------------------------------------------------------------------------------------------------------------------------------------------------------------------------------------------------------------------------------------------------------------------------------------------------------------------------------------------	-----------------------------------------------------------------------------------------------------------------------------------------------------------------------------------------------------------------------------------------------------------------------------------------------------------------------------------------------------------------------------------------------------------------------------------------------------



100 Thomas Johnson Drive, Frederick, MD 21702-4600 USA
 Phone (301) 663-1600 • 1-800-638-3326
 Fax (301) 663-1607 • 1-800-447-3326
 Website: www.edcoinc.com • Email: sales@edcoinc.com

ILLUSTRATION 1 : HANDLE BAR ASSEMBLY (STANDARD)

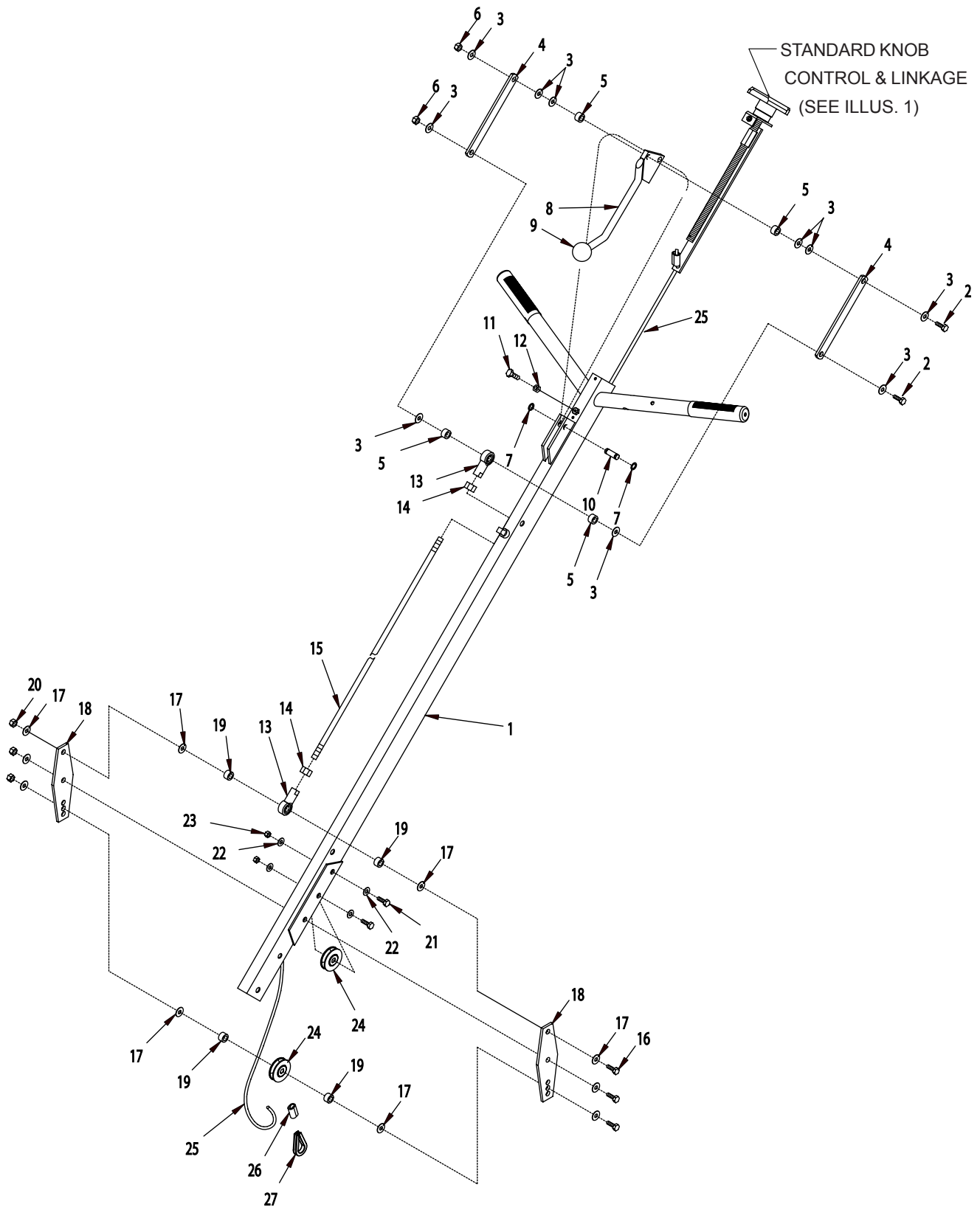
PART # 3668E



PARTS LISTING - ILLUSTRATION 1 : HANDLE BAR ASSEMBLY (STANDARD)			
ITEM#	PART#	DESCRIPTION	QTY.
1	3628	HANDLE BAR	1
2	3661	DECAL, BLADE ANGLE-FLAT/TILT	1
3	3614	KNOB CONTROL w/ 1/2-13x12" ROD	1
4	3642	BEARING, THRUST BALL 1/2"ID x 1"OD x 3/8"THK	1
5	3616	HANDLE CAP	1
6	10831	WASHER, LOCK, INT. TOOTH #10	1
7	10877	SCREW, CAP STSHW 10-24x1/2	1
8	3617	LINKAGE, ADJUSTING	1
9	3618	SLEEVE, NICROPRESS DOUBLE 3/16"	2
10	3619	CABLE, CONTROL 3/16x40-1/2"	1
11	4610	CABLE, THIMBLE 3/16"	1
12	10029	SCREW, CAP 3/8-24x1-3/4	1
13	10025	WASHER, FLAT 3/8	2
14	3621	PULLEY BEARING 1-3/4" DIA.x3/8" BORE	1
15	10004	NUT, LOCK 3/8-24	1
16	10315	SCREW, CAP 1/4-20 x1-1/2	1
17	4611	SLEEVE, NICROPRESS SINGLE 3/32"	1
18	3647	LEVER, CLUTCH, TROWEL	1
19	10015	NUT, LOCK 1/4-20	1
20	10314	SCREW, CAP 1/4-20x1-3/4	1
21	3699	LEVER LOCK, CLUTCH	1
22	10015	NUT, LOCK 1/4-20	1
23	79022	GRIP, HAND 1" MODEL RG	2
24	3648	CABLE, CLUTCH 3/32x70"L	1
25	3649	CABLE HOUSING, CLUTCH 57"POLY	1
26	4612	CABLE RETAINER TUBE, CLUTCH	1



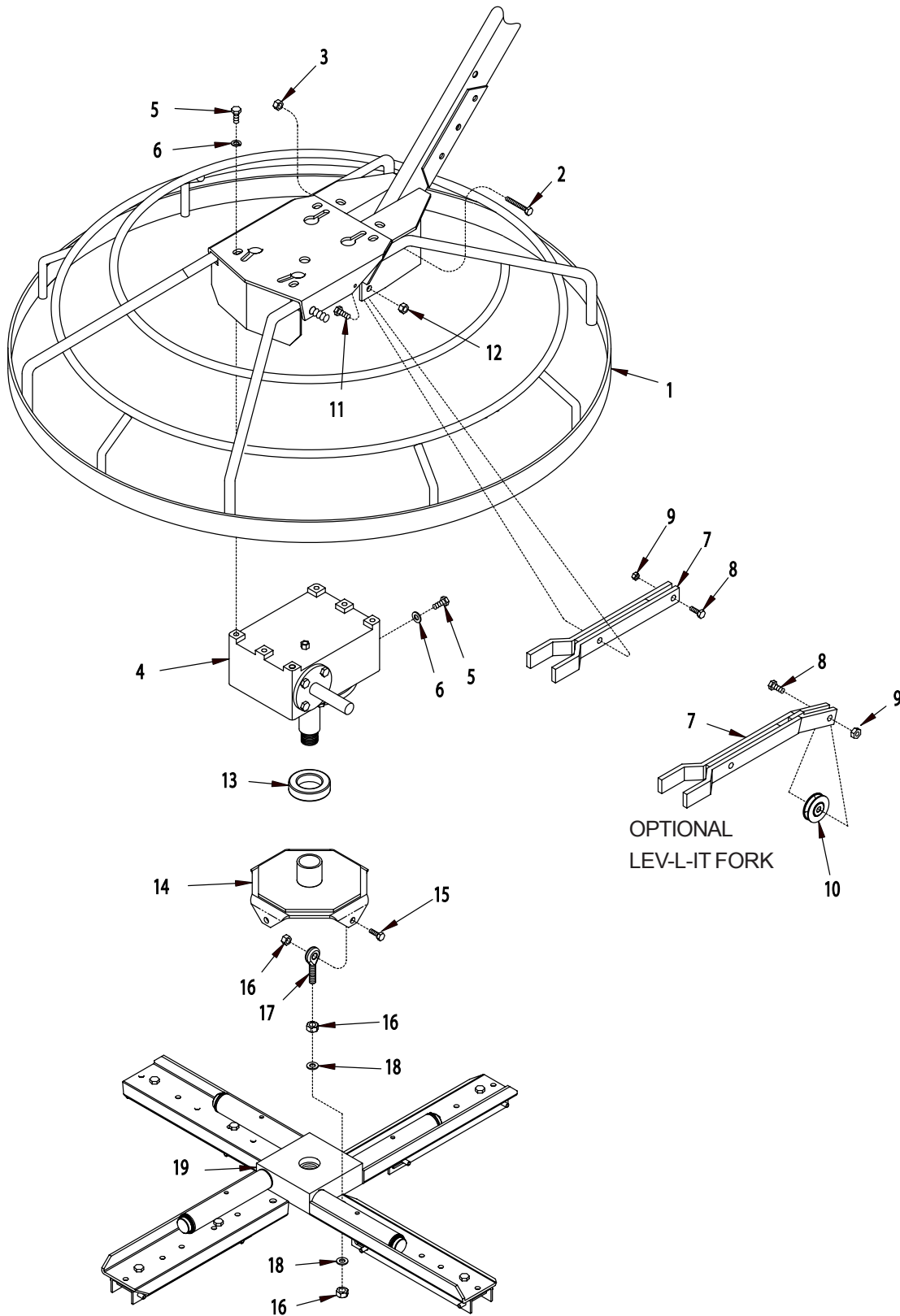
ILLUSTRATION 2 : OPTIONAL LEV-L-IT SYSTEM GROUPING



PARTS LISTING - ILLUSTRATION 2 : OPTIONAL LEV-L-IT SYSTEM GROUPING			
ITEM#	PART#	DESCRIPTION	QTY.
1	C84010	HANDLE FOR LEV-L-IT SYSTEM	1
2	10336	SCREW, CAP 3/8-24 x 2-1/4	2
3	10025	WASHER, FLAT 3/8	10
4	C84014	LINKAGE, CONNECTING	2
5	10011	SPACER, STEEL 5/8"OD x 3/8"ID x 3/8"THK	4
6	10004	NUT, LOCK 3/8-24	2
7	C10618	RETAINING RING, E-CLIP 3/8"	2
8	C84012	LEVER, "LEV-L-IT" CONTROL	1
9	14023	KNOB, BALL 1-3/8 W/ 1/2-13THD, BLK.	1
10	C84013	PIN, PIVOT 3/8 x 1-1/8	1
11	10834	SCREW, CAP 1/4-20 x 1/2	1
12	10013	NUT 1/4-20	1
13	10919	ROD END, FEMALE 3/8-24 R.H. THREAD	2
14	10014	NUT 3/8-24	2
15	C84015	LINKAGE, ROD 3/8 x 32"L	1
16	10336	SCREW, CAP 3/8-24 x 2-1/4	3
17	10025	WASHER, FLAT 3/8	10
18	C84016	BRACKET, PITCH	2
19	10011	SPACER, STEEL 5/8"OD x 3/8"ID x 3/8"THK	4
20	10004	NUT, LOCK 3/8-24	3
21	10029	SCREW, CAP 3/8-24 x 1-3/4	2
22	10025	WASHER, FLAT 3/8	4
23	10004	NUT, LOCK 3/8-24	2
24	3621	PULLEY BEARING 1-3/4DIA. x 3/8BORE	2
25	C84011	CABLE, CONTROL 3/16 x 51"	1
26	3618	SLEEVE, NICROPRESS DOUBLE 3/16"	1
27	4610	CABLE, THIMBLE 3/16"	1



**ILLUSTRATION 3 : FRAME DECK w/ GUARD RING
& SPIDER SUBASSEMBLY GROUPING**

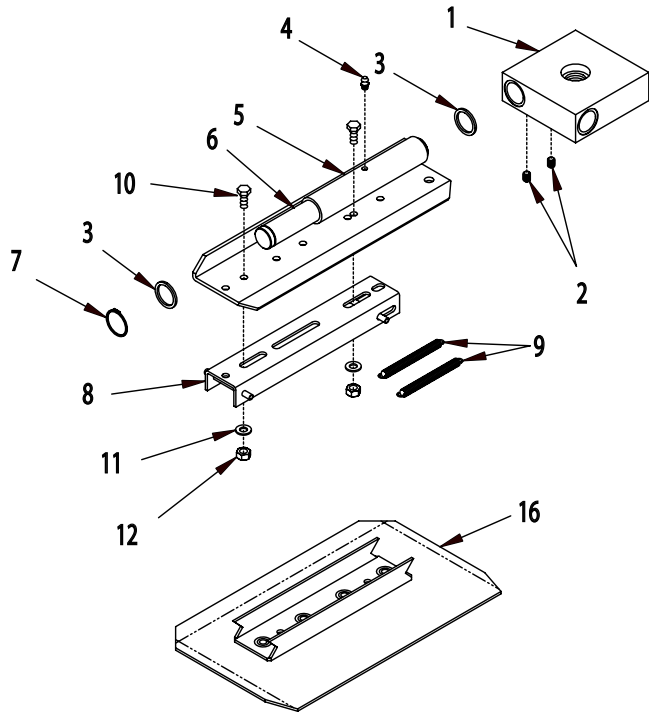


PARTS LISTING - ILLUSTRATION 3 : FRAME DECK w/ GUARD RING & SPIDER SUBASSEMBLY GROUPING			
ITEM#	PART#	DESCRIPTION	QTY.
1		FRAME & GUARD RING	1
	2401	24" TROWEL	
	3662	30" TROWEL	
	3644	36" TROWEL	
	4601	46" TROWEL	
2	10029	SCREW, CAP 3/8-24x1-3/4	2
3	10004	NUT, LOCK 3/8-24	2
4		TRANSMISSION, TROWEL	1
	3664	20:1 RATIO, STD. SPEED (SEE ILLUS. 8 FOR BREAKDOWN)	
	3664-RS	40:1 RATIO, REDUCED SPEED (SEE ILLUS. 9 FOR BREAKDOWN)	
5	10907	SCREW, CAP 3/8-16x3/4	6
6	10811	WASHER, LOCK 3/8	6
7		FORK, ADJUSTING	1
	3625	STANDARD	
	C84017	OPTIONAL FOR LEV-L-IT SYSTEM ONLY	
8	10816	SCREW, CAP 3/8-24x1-1/2	1
9	10004	NUT, LOCK 3/8-24	1
10	3621	PULLEY BEARING 1-3/4DIA.x3/8BORE	1
11	10029	SCREW, CAP 3/8-24x1-3/4	1
12	10004	NUT, LOCK 3/8-24	1
13	3609	BEARING, THRUST BALL 1-1/2"ID x 2-9/16"OD x 5/8"THK	1
14		PLATE, PITCHADJUSTMENT	1
	3626	24, 30, & 36" TROWELS	
	4603	46" TROWELS	
15		SCREW, CAP	4
	10021	3/8-24x1	
	10322	1/2-20x2 (46" TROWELS ONLY)	
16		NUT, LOCK	12
	10004	3/8-24	
	10205	1/2-20 (46" TROWELS ONLY)	
17		ROD END, MALE	4
	3605	3/8-24	
	4805	1/2-20 (46" TROWELS ONLY)	
18		WASHER, FLAT	8
	10025	3/8	
	10312	1/2 (46" TROWELS ONLY)	
19		SPIDER SUBASSEMBLY (SEE ILLUS. 4 FOR BREAKDOWN)	1
	2410	24" TROWEL	
	3620	30" TROWEL	
	36006	36" TROWEL	
	3680	46" TROWEL	

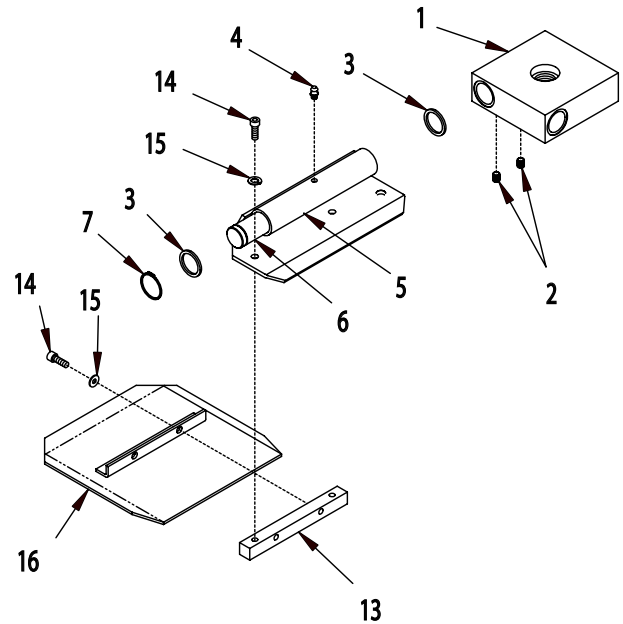


ILLUSTRATION 4 : SPIDER SUBASSEMBLY & BLADE GROUPING

30"- 46" POWER TROWELS



24" POWER TROWEL



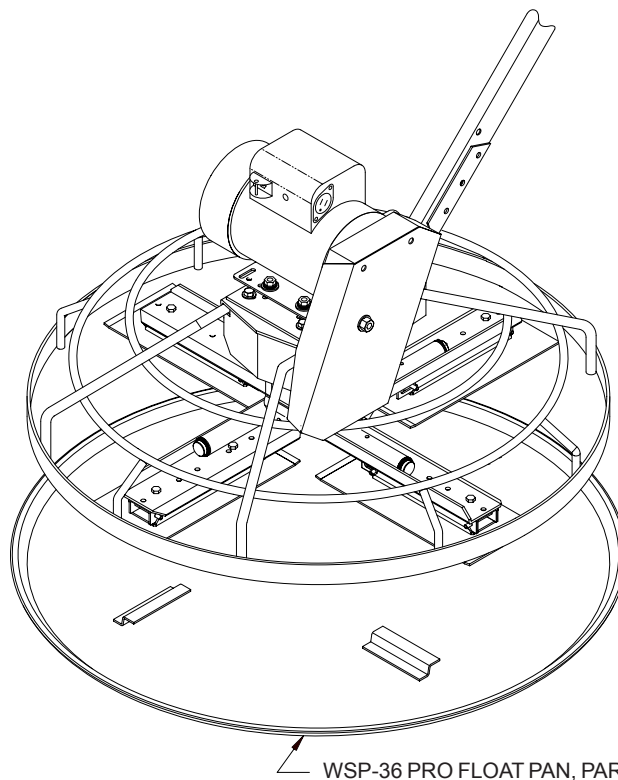
SELECT HERE FOR PARTS BREAKDOWN FOR BOLT-ON STYLE TROWEL BLADES & ADAPTERS

ITEM#	PART#	DESCRIPTION	QTY.	ITEM#	PART#	DESCRIPTION	QTY.
1	3637	HUB, 4-BLADE	1	9		SPRING, EXT. (REPLACEMENT ONLY) 2 PER ADAPTER	
2	10052	SCREW, SET 5/16-18x3/8	8	3636		6"L ("A" ADAPTER)	
3	3629	SPACER, COPPER THRUST 1-1/4"ODx1-1/64"IDx3/32"THK.	8	4605		11-1/2"L ("B" ADAPTER)	
4	10808	FITTING, GREASE 1/4-28 STRAIGHT	4	10	10053	SCREW, CAP 5/16-18x3/4	8
5		ARM, BLADE	4	11	10213	WASHER, FLAT 5/16	8
	2402	24" TROWEL		12	10807	NUT, LOCK 5/16-18	8
	3666	30" TROWEL		13	2406	BAR, BLADE MOUNTING	4
	36007	36" TROWEL		14	11639	SCREW, SKT. HD. CAP 5/16-18x5/8	16
	4606	46" TROWEL		15	10801	WASHER, LOCK 5/16	16
6		SHAFT, BLADE ARM	4	*16		COMBINATION TROWEL BLADE (SET OF 4)	1
	3635	24, 30, 36" TROWEL (9-11/16"L)			40470	C-4, 24" TROWEL	SET
	4604	46" TROWEL (13-15/16"L)			40270	C-2, 30" TROWEL	
7	10906	RETAINING RING, EXT. 1"	4		40040	C-1, 36" TROWEL	
8		ADAPTER	4		40070	C-3, 46" TROWEL	
	40197	"A", 30 & 36" TROWEL		*NOTE: COMBINATION BLADES ARE NOT INCLUDED WITH A NEW TROWEL. SEE BLADE CHART FOR A LIST OF ALL BLADES			
	40237	"B", 46" TROWEL					



POWER TROWEL BLADE CHART				
ITEM	PART#	DESCRIPTION	SIZE	TYPE
COMBINATION BLADE				
C-4	40470	24" TROWEL	8"x8"	BOLT-ON
C-2	40270	30" TROWEL	8"x11"	QUICK CHANGE
C-1	40040	36" TROWEL	8"x14"	QUICK CHANGE
C-3	40070	46" TROWEL	8"x18"	QUICK CHANGE
FLOAT BLADE				
M-4	40490	24" TROWEL	9"x8"	BOLT-ON
M-2	40290	30" TROWEL	9"x11"	QUICK CHANGE
M-1	40060	36" TROWEL	9"x14"	QUICK CHANGE
M-3	40090	46" TROWEL	9"x18"	QUICK CHANGE
FINISH BLADE				
	-----	N/A FOR 24" TROWEL		
F-2	40280	30" TROWEL	6"x11"	QUICK CHANGE
F-1	40050	36" TROWEL	6"x14"	QUICK CHANGE
F-3	40080	46" TROWEL	6"x18"	QUICK CHANGE

ILLUSTRATION 5 : OPTIONAL 36" FLOAT PAN



NOTE:
 FLOAT PAN MUST BE
 USED WITH F-1 FINISH
 BLADES, PART NO. 40050

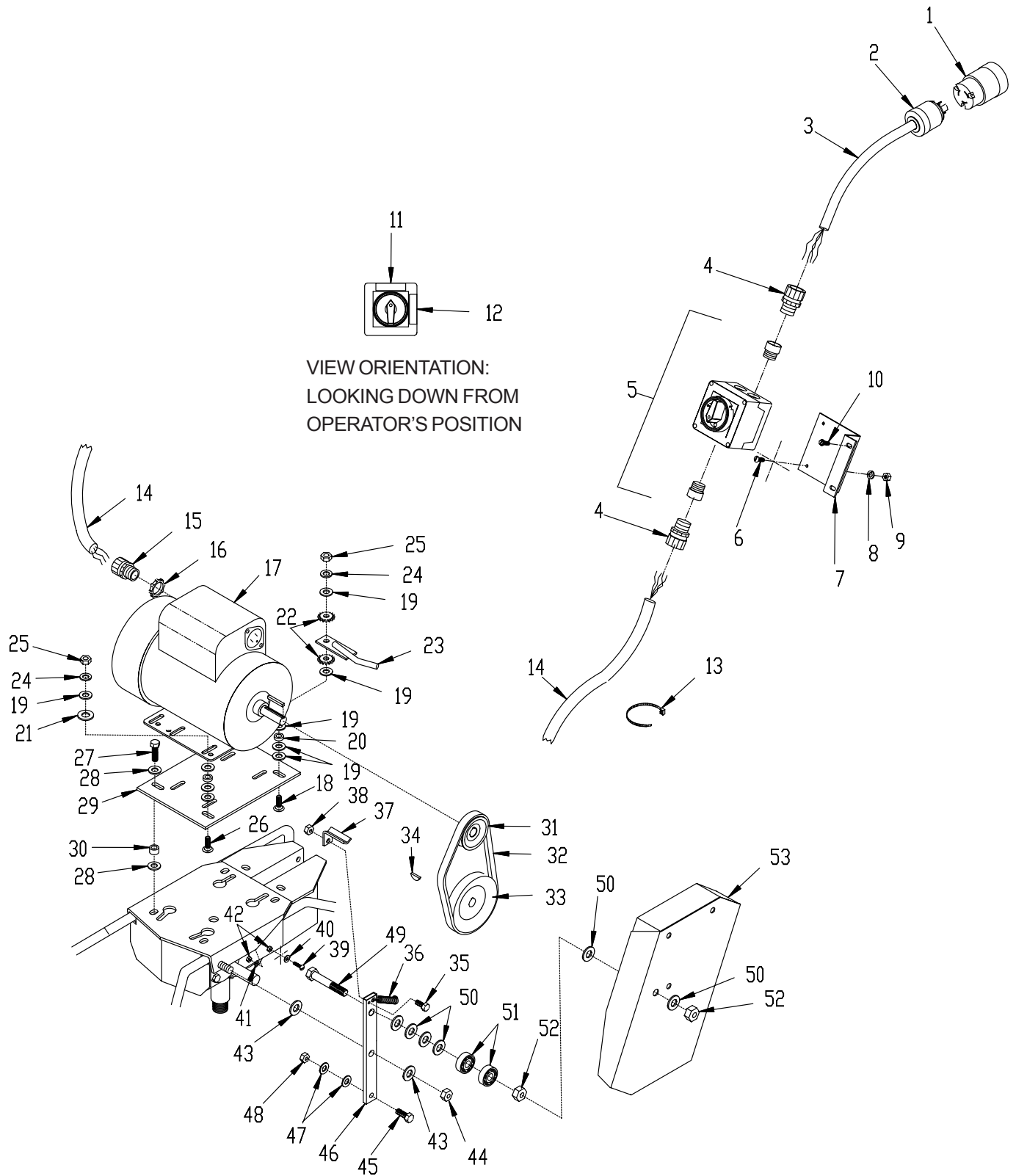
WSP-36 PRO FLOAT PAN, PART NO. 40710



100 Thomas Johnson Drive, Frederick, MD 21702-4600 USA
 Phone (301) 663-1600 • 1-800-638-3326
 Fax (301) 663-1607 • 1-800-447-3326
 Website: www.edcoinc.com • Email: sales@edcoinc.com

Printed in USA
 ©2005

ILLUSTRATION 6 : 1.5&2 HP ELECTRIC MOTOR GROUPING



VIEW ORIENTATION:
LOOKING DOWN FROM
OPERATOR'S POSITION

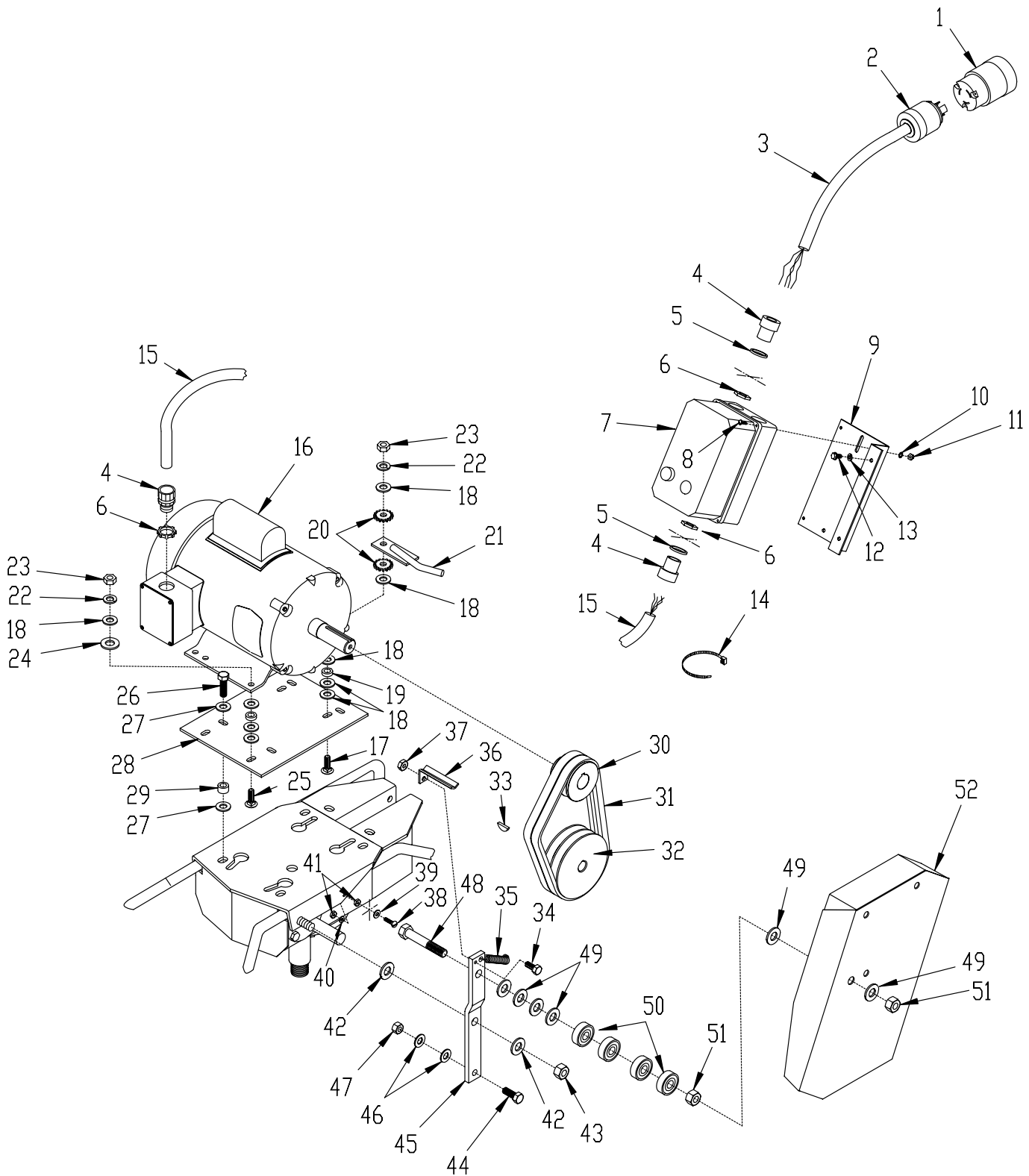


PARTS LISTING : ILLUSTRATION 6 : 1.5&2 HP ELECTRIC MOTOR GROUPING

ITEM#	PART#	DESCRIPTION	QTY.	ITEM#	PART#	DESCRIPTION	QTY.
1	40041	CONNECTOR, LOCKING 20A/125V	1	26	10820	BOLT, CARRIAGE 5/16-18x1-1/4 F.T.	3
2	40042	PLUG, LOCKING 20A/125V	1	27	10333	SCREW, CAP 3/8-16 x 1-1/4	4
3	C84018	WIRE HARNESS 12/3x24"	1	28	10025	WASHER, FLAT 3/8 SAE	8
4	41130	STRAIN RELIEF 1/2NPT x .550-.650"	2	29	36017	MOUNT, ELECTRIC MOTOR	1
5	77043	SWITCH, ROTARY CAM ON/OFF (INCLUDES (2) 1/2" NPT ADAPTERS)	1	30	10011	SPACER, STEEL 5/8OD x 3/8ID x 3/8T	4
6	11663	SCREW, MACHINE 8-32 x 1/2	4	31	3653	SHEAVE 3"OD x 1GR.B x 3/4"BORE	1
7	77042	BRACKET, SWITCH BOX	1	32	10051	BELT 5L-270	1
8	10461	WASHER, LOCK, INT. TOOTH #8	4	33	3654	SHEAVE 5"OD x 1GR.B x 3/4"BORE	1
9	10462	NUT 8-32	4	34	3685	KEY, WOODRUFF 3/16x 1 (#608)	1
10	10846	SCREW, CAP STSHW 1/4-20x1/2	2	35	10053	SCREW, CAP 5/16-18x3/4	1
11	91173	DECAL, OFF (HORZ.)	1	36	3658	SPRING, IDLER RETURN	1
12	91174	DECAL, ON (VERT.)	1	37	3656	BRACKET, BELT STOP 1-3/4"	1
13	10982	TIE, CABLE, BLACK NYLON 11-1/4"	1	38	10807	NUT, LOCK 5/16-18	1
14	C84030	WIRE HARNESS 12/3x65"	1	39	10833	SCREW, MACHINE 10-32x3/4	1
15	10959	STRAIN RELIEF 3/4 NPT X .550-.650"	1	40	10850	WASHER, FLAT #10 SAE	1
16	10740	CONDUIT LOCK NUT 3/4 NP	1	41	10831	WASHER, LOCK, INT. TOOTH #10	1
17		MOTOR	1	42	10832	NUT 10-32	2
	14004	BALDOR 1.5HP-1PH 60HZ 3450RPM		43	10312	WASHER, FLAT 1/2 SAE	2
	16007	LEESON 2HP-1PH-60HZ-3450RPM		44	10205	NUT, LOCK 1/2-20	1
18	10817	BOLT, CARRIAGE 5/16-18x1-1/2 F.T.	1	45	3646	SCREW, CABLE ANCHOR 3/8-24x1	1
19	10213	WASHER, FLAT 5/16 SAE	17	46	3645	ARM, CLUTCH, 9" STRAIGHT	1
20	10113	SPACER, STEEL 9/16ODx3/8IDx7/32	4	47	10025	WASHER, FLAT 3/8 SAE	2
21	10025	WASHER, FLAT 3/8 SAE	3	48	10004	NUT, LOCK 3/8-24	1
22	10436	WASHER, LOCK, EXT. TOOTH 5/16"	2	49	10202	SCREW, CAP 1/2-20x3	1
23	3624	BRACKET, BELT STOP	1	50	10312	WASHER, FLAT 1/2 SAE	6
24	10801	WASHER, LOCK 5/16	4	51	3659	BEARING, RADIAL BALL 1/2x1-3/8x7/16	2
25	10054	NUT 5/16-18	4	52	10205	NUT, LOCK 1/2-20	2
				53	3651	COVER, BELT	1



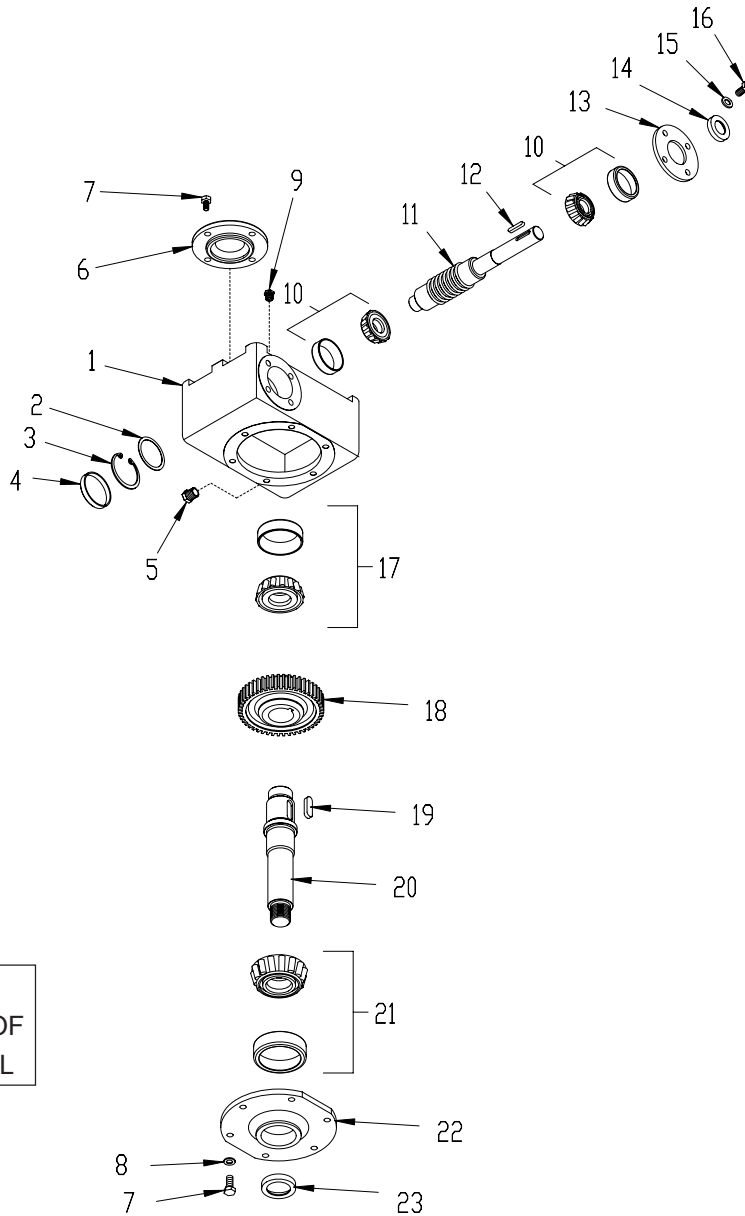
ILLUSTRATION 7 : 3 HP ELECTRIC MOTOR GROUPING



PARTS LISTING : ILLUSTRATION 7 : 3 HP ELECTRIC MOTOR GROUPING							
ITEM#	PART#	DESCRIPTION	QTY.	ITEM#	PART#	DESCRIPTION	QTY.
1	40041	CONNECTOR, LOCKING 20A/125V	1	27	10025	WASHER, FLAT 3/8 SAE	8
2	40042	PLUG, LOCKING 20A/125V	1	28	36058	MOUNT PLATE, 3 HP MOTOR	1
3	C84018	WIRE HARNESS 12/3x24"	1	29	10011	SPACER, STEEL 5/8OD x 3/8ID x 3/8T	4
4	10605	STRAIN RELIEF 3/4NPT x .650-.750"	2	30	79023	SHEAVE 3"OD x 2GR.B x 1-1/8"BORE	1
5	77081	WASHER, FLAT 1-9/16 x 1-1/16 x .06	2	31	10234	BELT 5L-290	2
6	10740	CONDUIT LOCK NUT 3/4 NP	2	32	77058	SHEAVE 5"OD x 2GR.B x 3/4"BORE	1
7	16405	STARTER 11-M1-BRF-P23-23-23060	1	33	3685	KEY, WOODRUFF 3/16x1 (#608)	1
8	10362	SCREW, MACHINE 8-32 x 3/4	4	34	10053	SCREW, CAP 5/16-18x3/4	1
9	86027	MOUNTING BRKT., LOVATO STARTER	1	35	3658	SPRING, IDLER RETURN	1
10	10461	WASHER, LOCK, INT. TOOTH #8	4	36	3652	BRACKET, BELT STOP 3"	1
11	10462	NUT 8-32	4	37	10807	NUT, LOCK 5/16-18	1
12	10846	SCREW, CAP STSHW 1/4-20 x 1/2	2	38	10833	SCREW, MACHINE 10-32x3/4	1
13	10038	WASHER, LOCK 1/4	2	39	10850	WASHER, FLAT #10 SAE	1
14	10982	TIE, CABLE, BLACK NYLON 11-1/4"	1	40	10831	WASHER, LOCK, INT. TOOTH #10	1
15	C84030	WIRE HARNESS 12/3x65"	1	41	10832	NUT 10-32	2
16	81014	MOTOR, BALDOR 3HP-1PH-60HZ-3450RPM	1	42	10312	WASHER, FLAT 1/2 SAE	2
17	10817	BOLT, CARRIAGE 5/16-18 x 1-1/2 F.T.	1	43	10205	NUT, LOCK 1/2-20	1
18	10213	WASHER, FLAT 5/16 SAE	17	44	3646	SCREW, CABLE ANCHOR 3/8-24x1	1
19	10113	SPACER, STEEL 9/16OD x 3/8ID x 7/32	4	45	3645B	ARM, CLUTCH, 9" BENT	1
20	10436	WASHER, LOCK, EXT. TOOTH 5/16"	2	46	10025	WASHER, FLAT 3/8 SAE	2
21	3624	BRACKET, BELT STOP	1	47	10004	NUT, LOCK 3/8-24	1
22	10801	WASHER, LOCK 5/16	4	48	10202	SCREW, CAP 1/2-20x3	1
23	10054	NUT 5/16-18	4	49	10312	WASHER, FLAT 1/2 SAE	6
24	10025	WASHER, FLAT 3/8	3	50	3659	BEARING, RADIAL BALL 1/2x1-3/8x7/16	4
25	10820	BOLT, CARRIAGE 5/16-18x1-1/4 F.T.	3	51	10205	NUT, LOCK 1/2-20	2
26	10333	SCREW, CAP 3/8-16x1-1/4	4	52	4651	COVER, BELT	1



**ILLUSTRATION 8 : 20:1 RATIO TRANSMISSION ASSEMBLY
FOR STANDARD SPEED TROWELS, PART# 3664**

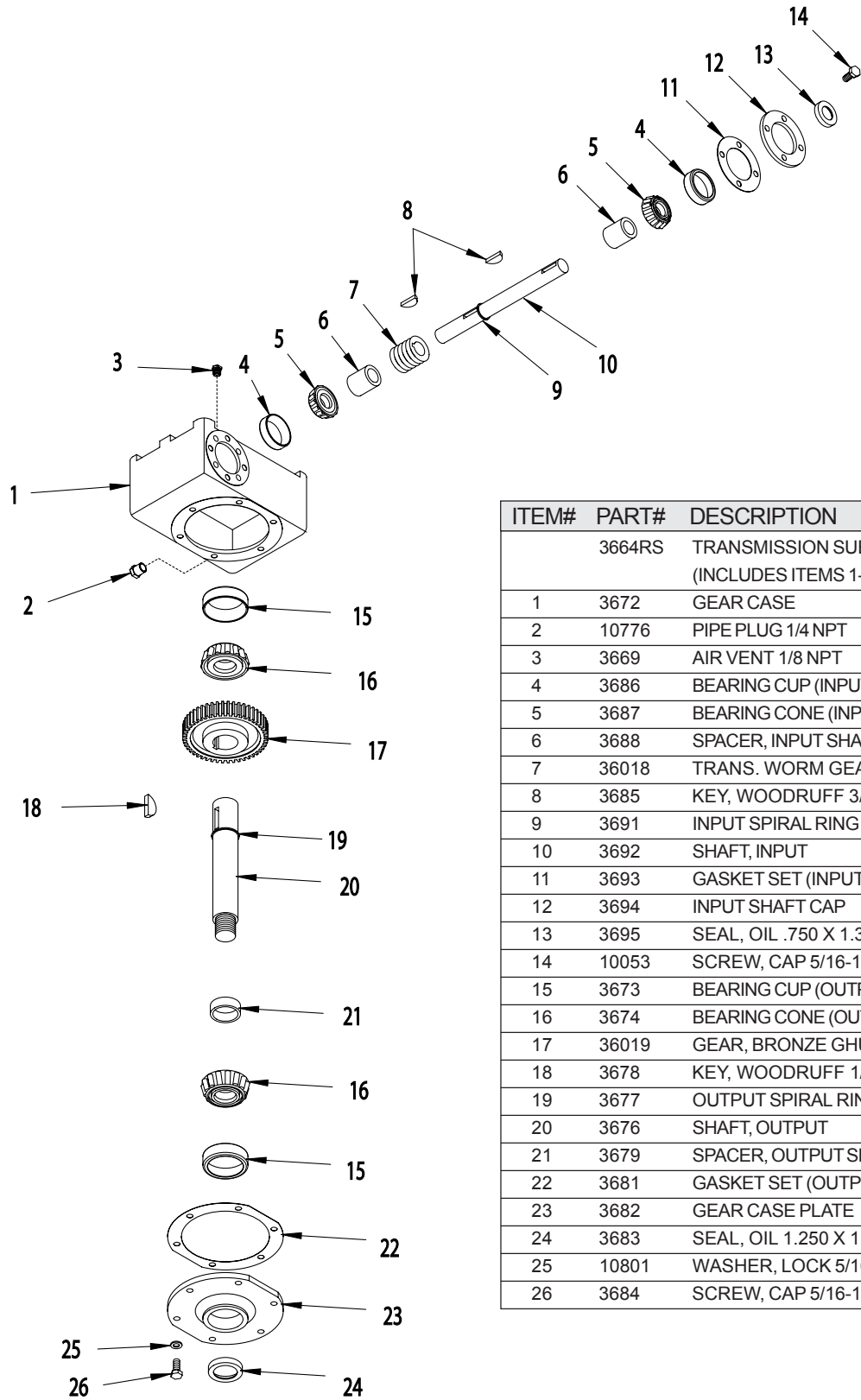


NOTE:
USES 16 OUNCES OF
MOBIL 634 GEAR OIL

ITEM#	PART#	DESCRIPTION	QTY.	ITEM#	PART#	DESCRIPTION	QTY.
1	36101	TRANS. GEAR CASE	1	12	36108	TRANS. INPUT KEY 3/16SQ x 1	1
2	36111	TRANS. PLASTIC SHIM (USE AS REQ'D.)	-	13	36104	TRANS. INPUT FLANGE	1
3	36112	RETAINING RING, INT. 47MM	1	14	36110	TRANS. OIL SEAL, INPUT 20 x 35 x 7	1
4	36113	TRANS. BLANKING CAP	1	15	10801	WASHER, LOCK 5/16	4
5	36105	TRANS. PIPE PLUG 1/4NPT	1	16	10053	SCREW, CAP 5/16-18x3/4	4
6	36102	TRANS. GEAR CASE TOP COVER	1	17	36114	BEARING, TAPERED ROLLER 30206A	1
7	10806	SCREW, CAP 5/16-18 x1	10	18	36115	TRANS. BRONZE WORM WHEEL 20:1	1
8	10801	WASHER, LOCK 5/16	6	19	36116	TRANS. WHEEL KEY 10MM x 30MM	1
9	36106	TRANS. AIR VENT 1/4NPT	1	20	36117	TRANS. OUTPUT SHAFT	1
10	36109	BEARING, TAPERED ROLLER 30204A	2	21	36118	BEARING, TAPERED ROLLER 30207A	1
11	36107	TRANS. WORM SHAFT 20:1	1	22	36103	TRANS. OUTPUT FLANGE	1
				23	36119	TRANS. OIL SEAL, OUTPUT 35 x 55 x 11	1



**ILLUSTRATION 9 : 40:1 RATIO TRANSMISSION ASSEMBLY
FOR REDUCED SPEED TROWELS, PART# 3664-RS**

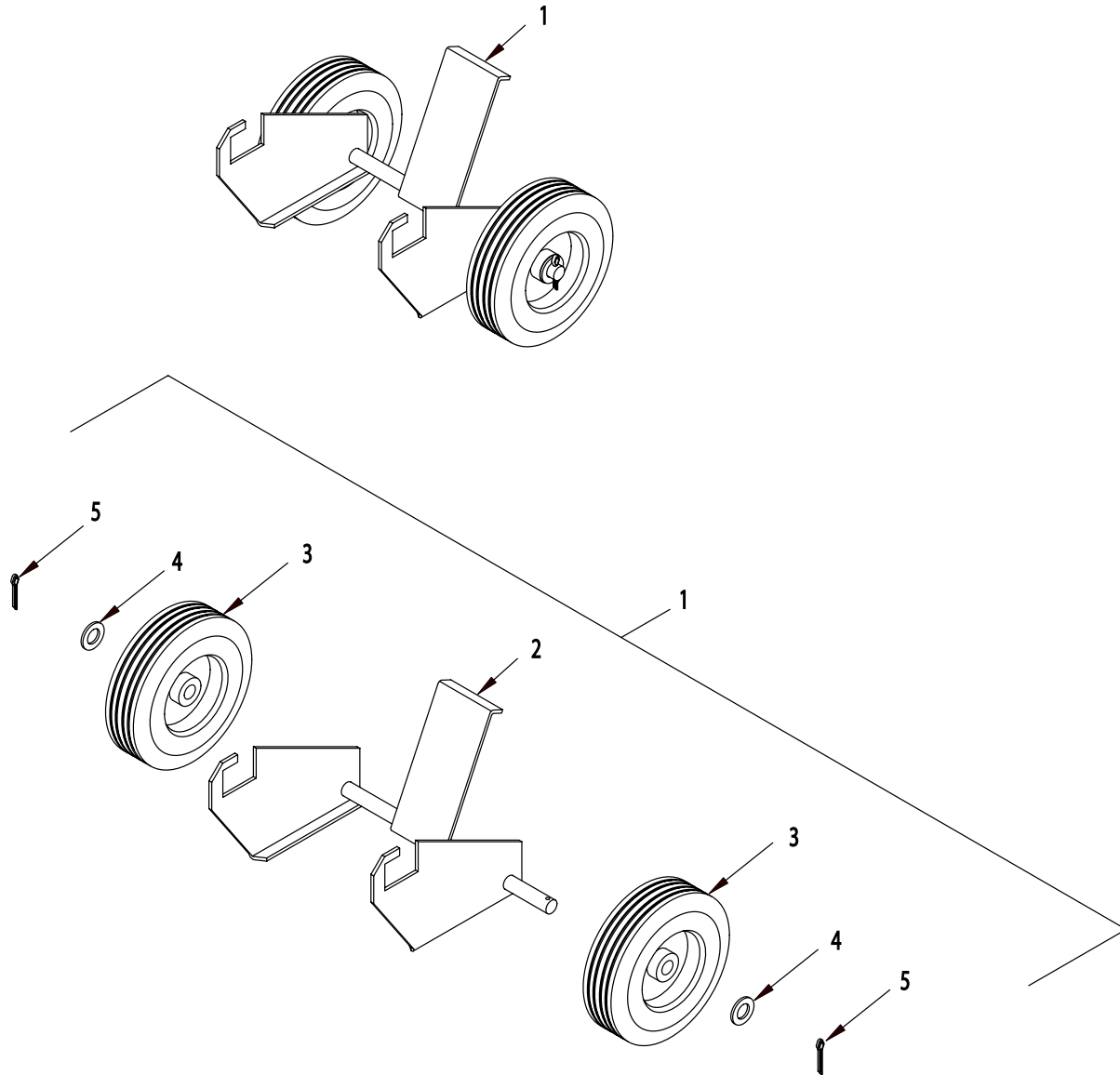


ITEM#	PART#	DESCRIPTION	QTY.
	3664RS	TRANSMISSION SUBASSY. (INCLUDES ITEMS 1-26)	1
1	3672	GEAR CASE	1
2	10776	PIPE PLUG 1/4 NPT	1
3	3669	AIR VENT 1/8 NPT	1
4	3686	BEARING CUP (INPUT)	2
5	3687	BEARING CONE (INPUT)	2
6	3688	SPACER, INPUT SHAFT	2
7	36018	TRANS. WORM GEAR W10A-1G X 3/4	1
8	3685	KEY, WOODRUFF 3/16x1 (#608)	2
9	3691	INPUT SPIRAL RING 3/4"	1
10	3692	SHAFT, INPUT	1
11	3693	GASKET SET (INPUT)	1
12	3694	INPUT SHAFT CAP	1
13	3695	SEAL, OIL .750 X 1.375 X .250 (INPUT)	1
14	10053	SCREW, CAP 5/16-18x3/4	4
15	3673	BEARING CUP (OUTPUT)	2
16	3674	BEARING CONE (OUTPUT)	2
17	36019	GEAR, BRONZE GHU-40:1	1
18	3678	KEY, WOODRUFF 1/4x1-1/4 (#810)	1
19	3677	OUTPUT SPIRAL RING 1-1/4"	1
20	3676	SHAFT, OUTPUT	1
21	3679	SPACER, OUTPUT SHAFT	1
22	3681	GASKET SET (OUTPUT)	1
23	3682	GEAR CASE PLATE	1
24	3683	SEAL, OIL 1.250 X 1.686 X .375 (OUTPUT)	1
25	10801	WASHER, LOCK 5/16	6
26	3684	SCREW, CAP 5/16-18x7/8	6



100 Thomas Johnson Drive, Frederick, MD 21702-4600 USA
 Phone (301) 663-1600 • 1-800-638-3326
 Fax (301) 663-1607 • 1-800-447-3326
 Website: www.edcoinc.com • Email: sales@edcoinc.com

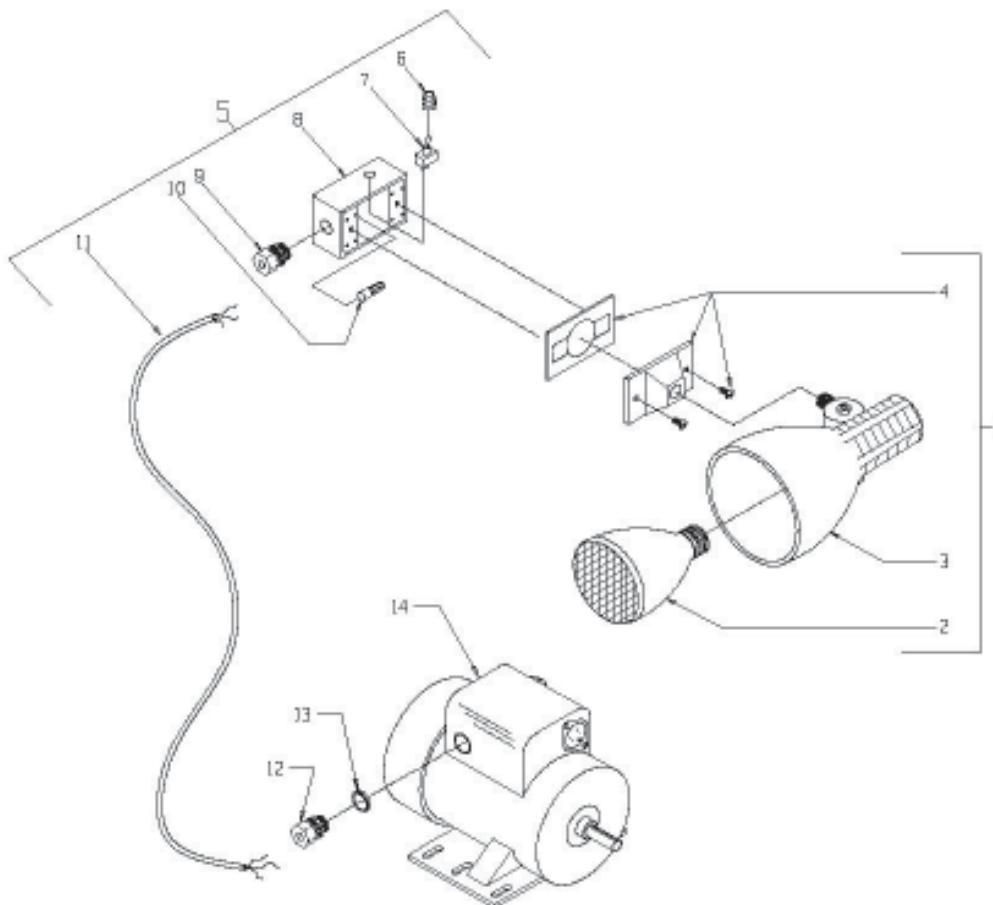
ILLUSTRATION 10 : OPTIONAL "TOTE-A-TROWEL"



ITEM#	PART#	DESCRIPTION	QTY.
1	81400	TAT II "TOTE-A-TROWEL" TRANSPORTER (INCLUDES ITEMS 2-5)	1
2	81401	MAIN FRAME, TAT II	1
3	79013	WHEEL 8 x 2-1/2 x 3/4"BRG	2
4	10009	WASHER, FLAT 3/4	2
5	10306	PIN, COTTER 3/16x1-1/4	2

ILLUSTRATION 11 : OPTIONAL 110 VOLT LAMP KIT

PART # C84001



ITEM#	PART#	DESCRIPTION	QTY.
1	C84007A	LAMP SUB-ASSEMBLY(INCLUDES ITEMS 2 – 4)	1
2	C84006	LIGHT BULB, FLOOD 75W	1
3	C84007	LAMP HOLDER	1
4	C84008	LAMP HOLDER BOX COVERW/ GASKET & SCREWS	1
5	C84009A	SWITCH BOX SUB-ASSEMBLY(INCLUDES ITEMS 6 – 11)	1
6	10674	BOOT, TOGGLE SWITCH	1
7	10633	SWITCH, TOGGLE SPST	1
8	C84009	BOX, SINGLE GANG WEATHERPROOF	1
9	40066	CONNECTOR, STRAIN RELIEF 1/2 NPT x .35 -.45 RANGE	1
10	10965	CONNECTOR, WIRE NUT (RED)	1
11	C84029	WIRE HARNESS 16/3 x 66"	1
12	10959	CONNECTOR, STRAIN RELIEF 3/4 NPT x .550-.650"	1
13	10740	CONDUIT LOCK NUT 3/4 NP	1
14	-----	MOTOR, ELECTRIC	1



100 Thomas Johnson Drive, Frederick, MD 21702-4600 USA
 Phone (301) 663-1600 • 1-800-638-3326
 Fax (301) 663-1607 • 1-800-447-3326
 Website: www.edcoinc.com • Email: sales@edcoinc.com

Printed in USA
 ©2005

LIMITED EQUIPMENT WARRANTY

Equipment Development Company, Inc. herein referred to as EDCO warrants that each new unit manufactured by EDCO to be free from defects in material and workmanship in normal use and service for a period of (1) one year (except in the case of the cutter drum assembly on all model concrete asphalt planes, in which case the warranty period shall be 90 days) from date of shipment to the original buyer or equipment rental center owner.

EDCO will, at its option, repair or replace, at the EDCO factory or at a point designated by EDCO any part, which shall appear to the satisfaction of EDCO inspection to have been defective in material or workmanship.

This warranty, does not apply to failure occurring as a result of abuse, misuse, negligent repairs, corrosion, erosion, normal wear and tear, alterations or modifications made to the product without express written consent of EDCO: or failure to follow the recommended operating practices and maintenance procedures as provided in the products operating and maintenance manuals.

This warranty does not obligate EDCO to bear any transportation charges in connection with the replacement or repair of defective parts. This warranty does not obligate EDCO to bear any expense for travel time or of personnel in connection with any service calls.

Accessories or equipment furnished and installed on the product by EDCO but manufactured by others, including but not limited to engines, motors, electrical equipment, transmissions, etc., shall carry the accessory manufacturers' own warranty.

THIS WARRANTY IS IN LIEU OF ALL OTHER WARRANTIES, EXPRESSED OR IMPLIED, OR STATUTORY, INCLUDING ANY WARRANTIES OF MERCHANTABILITY OR OF FITNESS FOR A PARTICULAR PURPOSE.

LIABILITY LIMITATIONS

The remedies of the user set forth under provisions of warranty outlined above are the exclusive and total liability of EDCO with the respect to their sale or the equipment and service furnished hereunder, in connection with the performance or breach thereof, or from the sale, delivery, installation, repair or technical direction covered by or furnished under the sale, whether based on contract, warranty, negligence, indemnity, strict liability, or otherwise shall not exceed the purchase price of the unit of equipment upon which such liability is based.

EDCO will not in any event be liable to the user, any successors in interest or any beneficiary or assignee relating to this sale for any consequential, incidental, indirect, special or punitive damages arising out of this sale or any breach thereof, or any defects on, or failure of, or malfunction of the equipment under this sale based upon loss of use, lost profits or revenue, interest, lost goodwill, work stoppage, impairment of other goods, loss by reason of shutdown or non-operation, increased expenses of operation of the equipment, cost of purchase or replacement power of claims of users or customers of the user for service interruption whether or not such loss or damage is based on contract, warranty, negligence, indemnity, strict liability, or otherwise.

EDCO reserves the right to modify, alter and improve any part or parts without incurring any obligation to replace any part or parts previously sold without such modified, altered or improved part or parts.

No person is authorized to give any other warranty or to assume any additional obligation on EDCO's behalf unless made in writing and signed by an officer of EDCO.

Equipment Development Company, Inc.

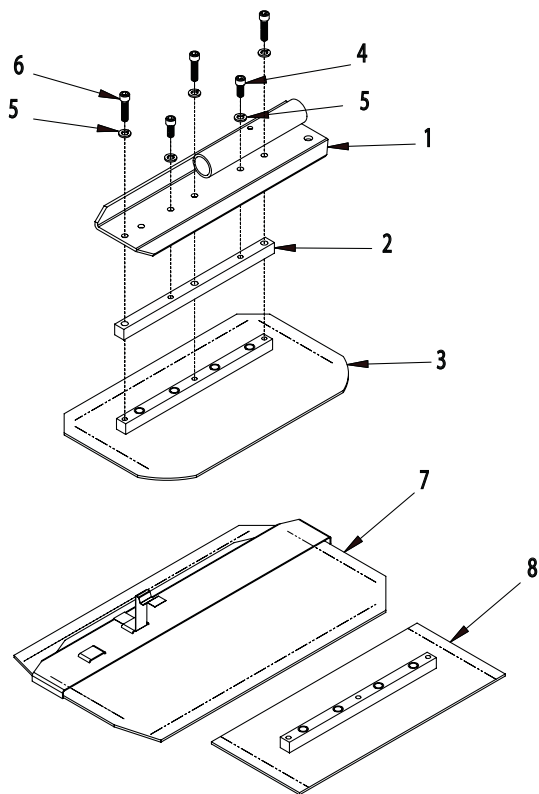
USE ONLY GENUINE EDCO PARTS AND ACCESSORIES

For your own safety, the safety of others and the life of your machine

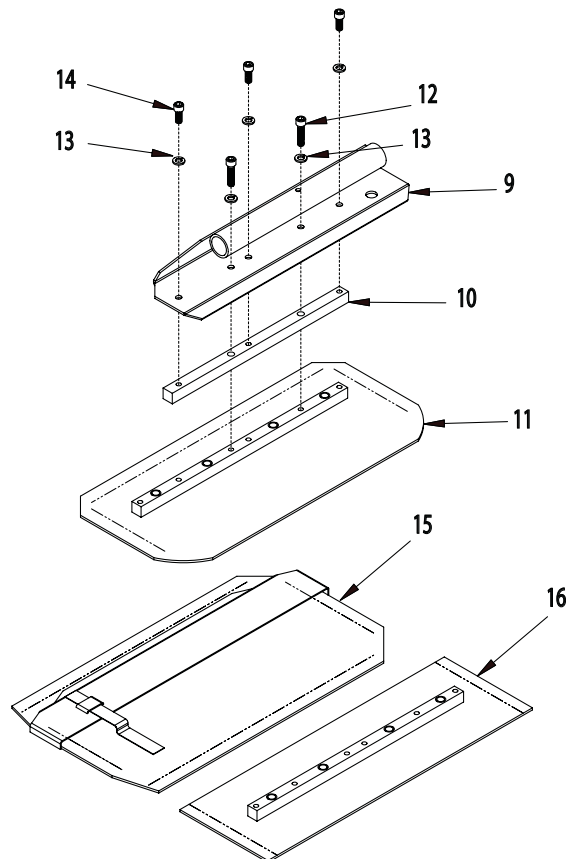


BOLT-ON STYLE TROWEL BLADE GROUPING -OPTIONAL-

36" TROWELS



46" TROWELS



ITEM#	PART#	DESCRIPTION	QTY.**
1	36007	ARM, BLADE 13" (STANDARD ARM ALSO USED FOR ADAPTERS)	1
2	36016	ADAPTER BAR, CONV. BLADE 5/8" SQ. x 10-1/4" (FITS CURRENT EDCO TROWELS WITH 13" ARM)	1
3	40040-C	C-1C COMB. TROWEL BLADE, CONV. BOLT-ON	1
4	11639	SCREW, SKT. HD. CAP 5/16-18 X 5/8	2
5	10801	WASHER, LOCK 5/16	5
6	C10577	SCREW, SKT HD CAP 5/16-18 X 1-1/4	3
7*	40060-CE	M-1CE FLOAT TROWEL BLADE, CONV. SLIP-ON (FITS CURRENT EDCO TROWELS ONLY WITH 13" ARM)	1
	40060-C	M-1C FLOAT TROWEL BLADE, CONV. SLIP-ON (FITS OLD EDCO TROWELS WITH 11" ARM)	1
8	40050-C	F-1C FINISH TROWEL BLADE, CONV. BOLT-ON	1
9	4618	ARM, BLADE 15-1/4" (CONV. BOLT-ON ONLY)	1
10	4619	ADAPTER BAR, CONV. BLADE 5/8" SQ. x 12"	1
11	40070-C	C-3C COMB. TROWEL BLADE, CONV. BOLT-ON	1
12	C10577	SCREW, SKT. HD. CAP 5/16-18 X 1-1/4	2
13	10801	WASHER, LOCK 5/16	5
14	11639	SCREW, SKT HD CAP 5/16-18 X 5/8	3
15*	40090-C	M-3C FLOAT TROWEL BLADE, CONV. SLIP-ON	1
16	40080-C	F-3C FINISH TROWEL BLADE, CONV. BOLT-ON	1
* SLIP-ON FLOAT BLADES REQUIRE BOLT-ON FINISH BLADES			
** QUANTITIES ARE BASED ON SINGLE BLADE ARM (MULTIPLY BY # OF BLADES PER TROWEL)			



100 Thomas Johnson Drive, Frederick, MD 21702-4600 USA
 Phone (301) 663-1600 • 1-800-638-3326
 Fax (301) 663-1607 • 1-800-447-3326
 Website: www.edcoinc.com • Email: sales@edcoinc.com

Printed in USA
 ©2006