

GUTTER GATOR

PARTS LIST MANUAL



MODEL CD-5-H
SKU # 63100-H

STARTING SERIAL # 120510101

READ AND UNDERSTAND THE OPERATOR'S INSTRUCTION MANUAL THOROUGHLY BEFORE ATTEMPTING TO OPERATE THIS EQUIPMENT.



Death or serious injury could occur if this equipment is used improperly.



SAFETY MESSAGES

- Safety Instructions are preceded by a graphic alert symbol of DANGER, WARNING, or CAUTION.



Indicates an imminent hazard which, if not avoided, will result in death or serious injury.



Indicates an imminent hazard which, if not avoided, can result in death or serious injury.



Indicates hazards which, if not avoided, could result in serious injury and or damage to the equipment.

AIR POWERED EQUIPMENT



- When operating this equipment, the operator must wear approved job related safety attire. Eye and hearing protection must be worn at all times while equipment is in use as sound levels exceed 92 dBA. Steel toe safety shoes should be worn. Head protection is required if work is performed overhead. Wear proper dust mask based on material being removed.
- Use the correct size air hose for the tool, 1/2" diameter (minimum). Hose and fittings must be rated for safe handling in excess of 100 PSI pressure. The working pressure of this tool is 80-90 PSI and should never be allowed to exceed 100 PSI.
- Limit the hose length to 30 feet (10 meters) maximum.
Note: The pressure drop of 1/2" diameter hose is approximately 1 PSI per 90 linear feet.
- Limit the hose length to 30 feet (10 meters) maximum.
Note: The pressure drop of 3/8" diameter hose is approximately 3 PSI per 90 linear feet.
- A filter/water separator must be provided on the air source to afford an adequate supply of clean, dry air to this machine.



• Disconnect the air supply before performing any maintenance on this machine. Use only genuine EDCO parts with this equipment. Failure to do so may result in serious bodily injury or death.

• Replace any damaged parts immediately. Use only genuine EDCO parts.

• Do **NOT** force the tool into the work. The hammering action of the tool will perform the work for you. If the tool does not seem to perform the work to your specifications, check the air supply to verify proper air pressure and lubricator is functioning properly. If if above suggestions do not remedy the problem call our customer service department at 1-800-638-3326 for possible solutions and trouble shooting.

AIR POWERED EQUIPMENT CONTINUED

• To activate machine, attach the air source, firmly grip the machine and then turn the hand lever on the air valve on.

• After turning the air valve hand lever off, the tool will continue to operate for a few seconds. This is a normal result of stored up pressuer in the machine casing being released gradually. **Be sure to firmly grip the machine until ALL air leaves the chamber.**

• Remove the air source from the machine when not in use.



• This equipment will create dust from the material being removed. That dust may contain a chemical known to the state of California to cause cancer and/or birth defects or other reproductive harm. Check the chemical properties of the materials to be removed.



• It is the operator's responsibility to keep other people (workers, pedestrians, bystanders, etc.) away during operation. Block off the work area in all directions with roping, safety netting, etc. for a safe distance. Failure to do so may result in others being injured by flying debris or exposing them to harmful dust and noise.

DUST WARNING

Some dust created by power sanding, sawing, grinding, drilling, and other construction activities contains chemicals known to cause cancer, birth defects, or other reproductive harm. Some examples of these chemicals are:

- Lead from lead-based paints, and
- Crystalline silica from bricks and concrete and other masonry products.

Your risk of exposure to these chemicals varies depending on how often you do this type of work. To reduce your risk: work in a well ventilated area, use a dust control system, such as an industrial-style vacuum, and wear approved

OPERATOR RESPONSIBILITIES

- Read and follow all safety decals and labels.
- Maintain a safe operating distance to other personnel.
- Be familiar with all aspects of the machine's operation and controls before applying power to the equipment.
- Use the correct accessory for the job being performed and material being removed. Make sure accessories are mounted correctly.
- Never operate this machine while under the influence of drugs or alcohol, while taking medications that impair the senses or reactions, or when excessively tired or under stress.
- Follow the instructions in the operator's manual and exercise caution.
- Comply with all local safety and health regulations as well as EPA and OSHA regulations.
- Maintain a copy of the equipment's operator's manual with the machine for reference at all times.

GUTTER GATOR

PARTS LIST MANUAL

TABLE OF CONTENTS

| <u>Section</u> | <u>Page Number</u> |
|---|--------------------|
| Safety Messages & General Instructions | 2 |
| How To Order Replacement Parts | 3 |
| Illustration 1: Main Grouping | 4, 5 |
| Illustration 2: Lubricator & Air Hose Grouping | 6, 7 |
| Illustration 3: Cylinder Block Grouping | 8, 9 |
| Illustration 4: Piston & Cylinder Assembly | 10 |
| Illustration 5: Scabbler Accessories | 11 |
| Limited Equipment Warranty of Sale - Terms & Conditions | 12 (Back Page) |

HOW TO ORDER REPLACEMENT PARTS

- To insure product safety and reliability, always use genuine EDCO replacement parts when making repairs to the equipment.
- When calling for parts, specify the MODEL and SERIAL number of the machine, which can be found on the NAME PLATE. Keep that information in the space provided. In addition to this information, give part number, description, and quantity as listed on the parts list to your parts representative.
- Please note: Due to improvements and changes in the equipment, the illustrations shown may be different than the actual machine.

FILL IN INFORMATION BELOW

Date of Purchase _____

Model # _____

Serial # _____

SKU # _____



A Division of Equipment Development Company, Inc.

100 Thomas Johnson Drive, Frederick, MD 21702-4600 USA

Phone (301) 663-1600 • 1-800-638-3326

Fax (301) 663-1607 • 1-800-447-3326

Website: www.edcoinc.com

Email: sales@edcoinc.com

Printed in USA

JWA ©2012

Page 3

ILLUSTRATION 1: MAIN GROUPING

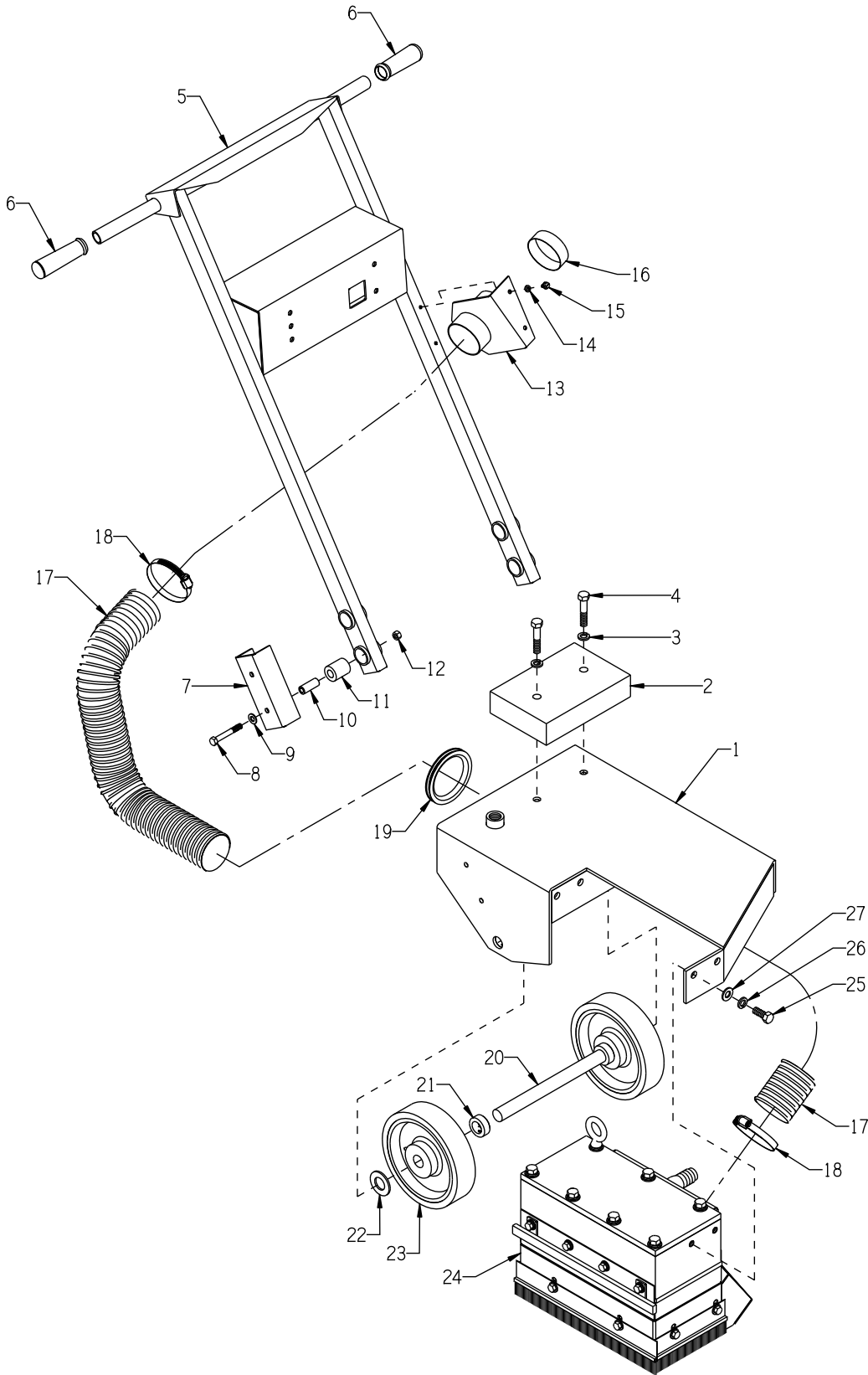

| PARTS LISTING - ILLUSTRATION 1: MAIN GROUPING | | | |
|--|---------------|--|-------------|
| ITEM # | PART # | DESCRIPTION | QTY. |
| 1 | 63152 | MAIN FRAME, CD-5-H | 1 |
| 2 | 86345 | WEIGHT BLOCK, 30 LB. | 1 |
| 3 | 10045 | WASHER, LOCK 1/2 ZINC | 2 |
| 4 | 10323 | SCREW, CAP 1/2-13 X 2-1/2 | 2 |
| 5 | 63151 | HANDLE BAR, CD-5 | 1 |
| 6 | 10608 | GRIP, HAND 1" MODEL AT | 2 |
| 7 | 63105 | BRACKET, HANDLE BAR MOUNTING, CD-5 | 2 |
| 8 | 10815 | SCREW, CAP 3/8-24 X 2-3/4 | 4 |
| 9 | 10025 | WASHER, FLAT 3/8 SAE ZINC | 4 |
| 10 | 63107 | TUBE, BUSHING CENTER, CD-5 5/8 X 3/8 X 1-9/16 | 4 |
| 11 | 63106 | BUSHING, RUBBER 1-1/4 X 5/8 X 1-5/8 | 4 |
| 12 | 10004 | NUT, HEX LOCK 3/8-24 ZINC | 4 |
| 13 | 63112 | BRACKET, VACUUM HOSE 3" | 1 |
| 14 | 10038 | WASHER, LOCK 1/4 ZINC | 2 |
| 15 | 10846 | SCREW, CAP STSHW 1/4-20 X 1/2 | 2 |
| 16 | 64030 | CAP, END 3" BLUE PLASTIC | 1 |
| 17 | 63154 | HOSE, FLEX 3"ID X 41"L | 1 |
| 18 | 10849 | CLAMP, HOSE, SAE #52, ADJ. TO 3-3/4 | 2 |
| 19 | 63131 | TRIM 12", PUSH ON EDGE, CD-5 | 1 |
| 20 | 63053 | AXLE SHAFT 1"DIA. X 15"L, CD-5 | 1 |
| 21 | 10427 | COLLAR, LOCKING 1"ID | 2 |
| 22 | 10008 | WASHER, FLAT 1" SAE ZINC | 2 |
| 23 | 63050 | WHEEL 8 X 1-15/16 X 1"BRG., POLY | 2 |
| 24 | ----- | CYLINDER BLOCK ASSEMBLY (REFER TO ILLUS. 3 FOR BREAKDOWN) | 1 |
| 25 | 11672 | SCREW, CAP 1/2-13 X 1-1/4 | 4 |
| 26 | 10045 | WASHER, LOCK 1/2 ZINC | 4 |
| 27 | 10312 | WASHER, FLAT 1/2 SAE ZINC | 4 |

ILLUSTRATION 2: LUBRICATOR & AIR HOSE GROUPING

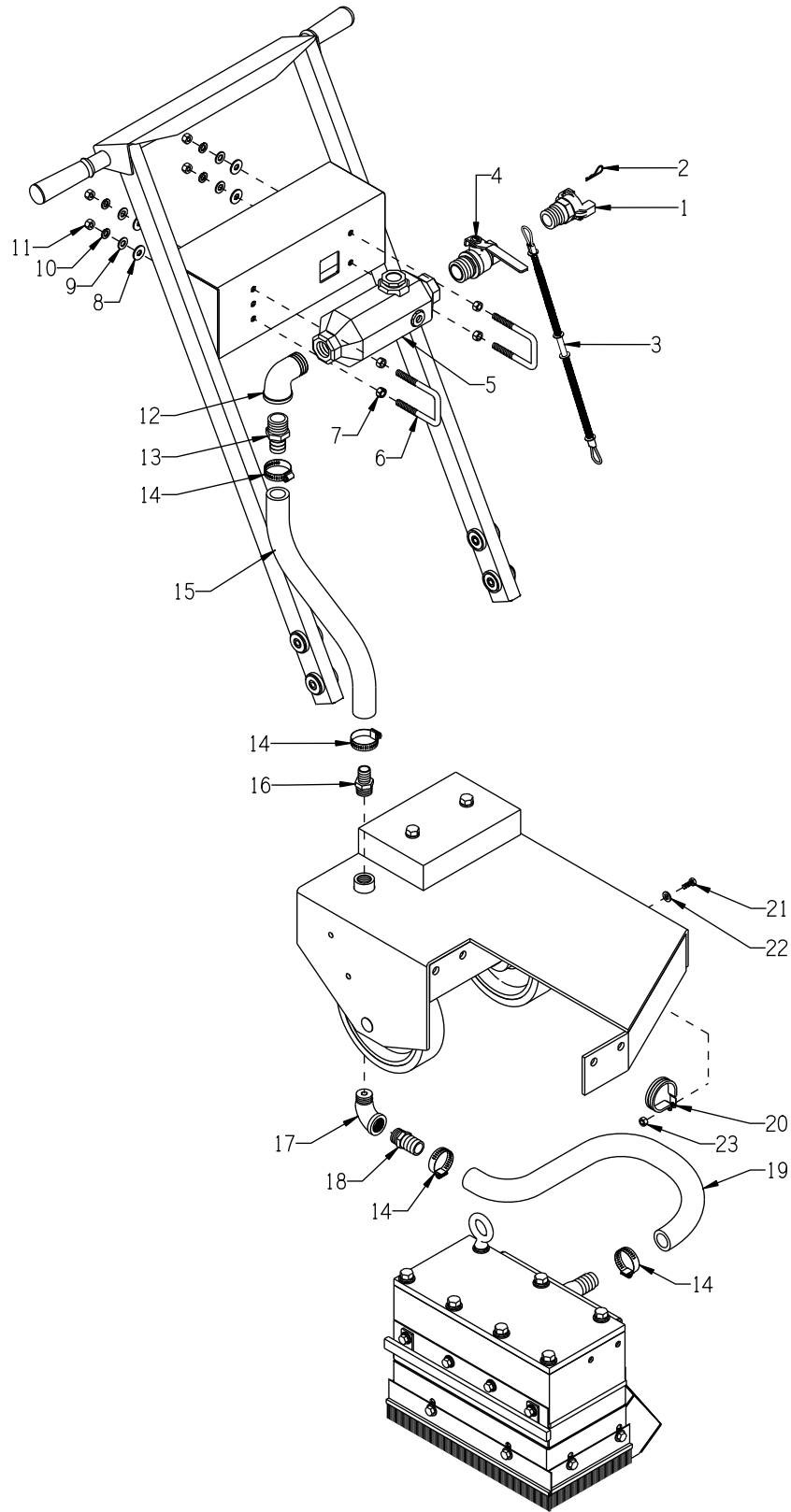

| PARTS LISTING - ILLUSTRATION 2: LUBRICATOR & AIR HOSE GROUPING | | | |
|---|---------------|---------------------------------------|-------------|
| ITEM # | PART # | DESCRIPTION | QTY. |
| 1 | 63129 | COUPLER, AIR HOSE, 1"MPT | 1 |
| 2 | 61066 | PIN, HAIR COTTER, 1/2"-3/4" SHAFT | 1 |
| 3 | 63040 | CABLE, WHIPCHEK SAFETY 1/8 X 20-1/4 | 1 |
| 4 | 63128 | VALVE, BALL 1"FPT X 1"MPT, CD-5 | 1 |
| 5 | 63150 | LUBRICATOR, 1 PINT, 1"NPT, CD-5 | 1 |
| 6 | 63214 | U-BOLT, SQ. BEND, 2 X 4.63, CD-5 | 2 |
| 7 | ----- | NUT, HEX 3/8-16 (INCLUDED W/ U-BOLT) | 4 |
| 8 | ----- | WASHER, FLAT 3/8 (INCLUDED W/ U-BOLT) | 4 |
| 9 | 10025 | WASHER, FLAT 3/8 SAE ZINC | 4 |
| 10 | 10811 | WASHER, LOCK 3/8 ZINC | 4 |
| 11 | 10404 | NUT, HEX 3/8-16 ZINC | 4 |
| 12 | 50083 | ELBOW, STREET 1"NPT X 90 (BLACK) | 1 |
| 13 | 63127 | BARB, 1"HOSE X 1"MPT (BRASS) | 1 |
| 14 | 10784 | CLAMP, HOSE, SAE #20, ADJ. TO 1-3/4 | 4 |
| 15 | 63120 | HOSE, AIR 1"ID X 17-5/8"L, CD-5 | 1 |
| 16 | 63216 | BARB, 3/4HOSE X 3/4MPT (BRASS) | 1 |
| 17 | 10727 | ELBOW, STREET 3/4NPT X 90 (BLACK) | 1 |
| 18 | 63047 | BARB, 1"HOSE X 3/4MPT | 1 |
| 19 | 63155 | HOSE, AIR 1"ID X 24-5/8"L, CD-5-H | |
| 20 | 11566 | CLAMP, LOOM, 1-3/4" (SAE SIZE 28) | 1 |
| 21 | 10018 | SCREW, CAP 1/4-20 X 3/4 | 1 |
| 22 | 10602 | WASHER, FLAT 1/4 SAE ZINC | 1 |
| 23 | 10861 | NUT, KEPS LOCK 1/4-20 ZINC | 1 |

ILLUSTRATION 3: CYLINDER BLOCK GROUPING

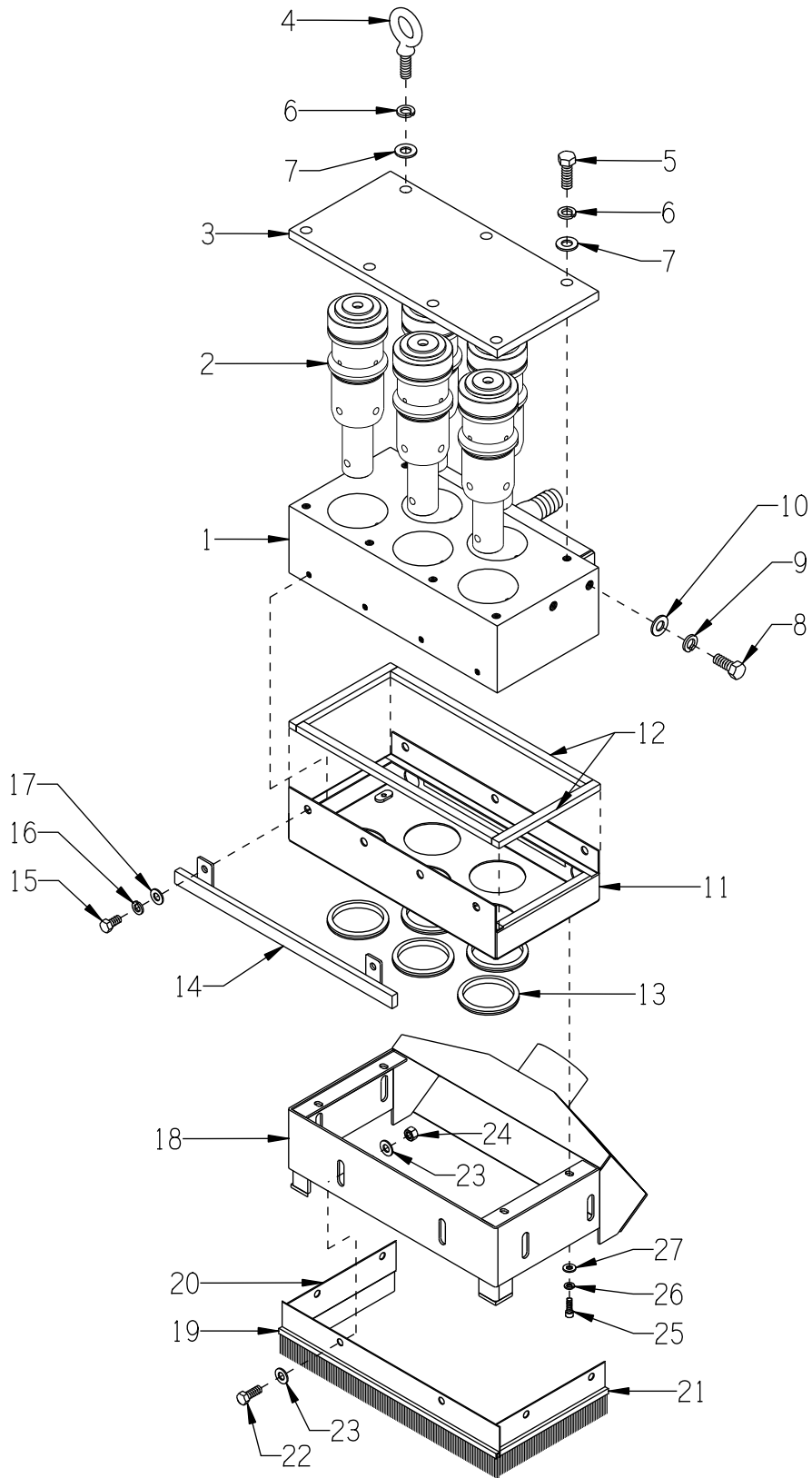

| PARTS LISTING - ILLUSTRATION 3: CYLINDER BLOCK GROUPING | | | |
|--|--------|--|------|
| ITEM # | PART # | DESCRIPTION | QTY. |
| 1 | 63024 | BLOCK WELDMENT, CYLINDER | 1 |
| 2 | 63010 | PISTON & CYLINDER ASSEMBLY | 5 |
| 3 | 63023 | PLATE, CYLINDER BLOCK TOP | 1 |
| 4 | 10837 | BOLT, EYE 1/2-13 X 1-1/2 X 1-1/8"ID | 1 |
| 5 | 10356 | SCREW, CAP 1/2-13 X 1-1/2 | 6 |
| 6 | 10045 | WASHER, LOCK 1/2 ZINC | 7 |
| 7 | 10312 | WASHER, FLAT 1/2 SAE ZINC | 7 |
| 8 | 11672 | SCREW, CAP 1/2-13 X 1-1/4 | 4 |
| 9 | 10045 | WASHER, LOCK 1/2 ZINC | 4 |
| 10 | 10312 | WASHER, FLAT 1/2 SAE ZINC | 4 |
| 11 | 63102 | EXHAUST BOX, CD-5 | 1 |
| 12 | 63026 | SEALING STRIPS, EXHAUST BOX 1/2"W X 3/8"THK X 7"L (2 REQ'D.) 1/2"W X 3/8"THK X 13-1/2"L (2 REQ'D.) | 1 |
| 13 | 63110 | GROMMET 2-1/2ID X 1/16GRV.X 2-3/4GD | 5 |
| 14 | 63153 | RAIL, RUB, CD-5-H | 1 |
| 15 | 10907 | SCREW, CAP 3/8-16 X 3/4 | 7 |
| 16 | 10811 | WASHER, LOCK 3/8 ZINC | 7 |
| 17 | 10025 | WASHER, FLAT 3/8 SAE ZINC | 7 |
| 18 | 63103 | SKIRT, 3"VACUUM, CD-5 | 1 |
| 19 | 63156 | BRUSH 1-1/2 X 15, RIGHT SIDE CD-5-H | 1 |
| 20 | 63157 | BRUSH, 1-1/2 x 7-1/2, REAR CD-5-H | 1 |
| 21 | 63158 | BRUSH, 1-1/2 x 7-1/2, FRONT CD-5-H | 1 |
| 22 | 10021 | SCREW, CAP 3/8-24 X 1 | 6 |
| 23 | 10025 | WASHER, FLAT 3/8 SAE ZINC | 12 |
| 24 | 10152 | NUT, HEX NYLON LOCK 3/8-24 | 6 |
| 25 | 11573 | SCREW, SKT. HD. CAP 1/4-20 X 3/4 | 4 |
| 26 | 10038 | WASHER, LOCK 1/4 ZINC | 4 |
| 27 | 10602 | WASHER, FLAT 1/4 SAE ZINC | 4 |

ILLUSTRATION 4: PISTON & CYLINDER ASSEMBLY

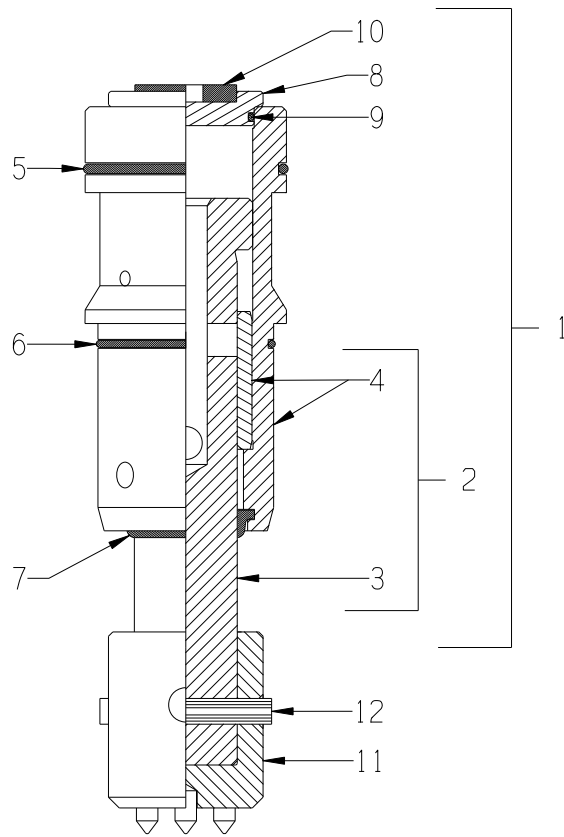

| ITEM # | PART # | DESCRIPTION | QTY.* |
|--------|----------------|---|-------|
| 1 | 63010 | PISTON & CYLINDER ASSY. (ITEMS 2 - 10) | 5 |
| 2 | 63010S | PISTON & CYLINDER SET (ITEMS 3 & 4) | 1 |
| 3 | 63018 | PISTON | 1 |
| 4 | 63070 | CYLINDER & LINER ASSEMBLY | 1 |
| 5 | 63016 | O-RING #231, 1/8 X 2-5/8"ID | 1 |
| 6 | 63017 | O-RING #141, 3/32 X 2-5/16"ID | 1 |
| 7 | 63019 | WIPER RING, PISTON | 1 |
| 8 | 63012 | CAP, CYLINDER TOP | 1 |
| 9 | 63013 | O-RING #133, 3/32 X 1-13/16"ID | 1 |
| 10 | 63011 | INSERT, TOP CAP | 1 |
| 11 | 18810 18820 | TUNGSTEN CARBIDE BIT W/ PIN (ITEM 12) UNIVERSAL BIT W/ PIN, 5-POINT UNIVERSAL BIT W/ PIN, 9-POINT | 1 |
| 12 | 63056 | PIN, H.D. COILED SPRING 3/8 X 2-1/2 (INCLUDED W/ ITEM 11) | 1 |

*NOTE: THERE ARE 5 TOTAL ASSEMBLIES (ITEM 1) PER SCABBLER.
 QUANTITIES FOR ITEMS 2 THRU 10 ARE BASED ON 1 ASSEMBLY.
 ITEMS 11 & 12 ARE NOT INCLUDED WITH THE 63010 ASSEMBLY.

ILLUSTRATION 5: SCABBLER ACCESSORIES

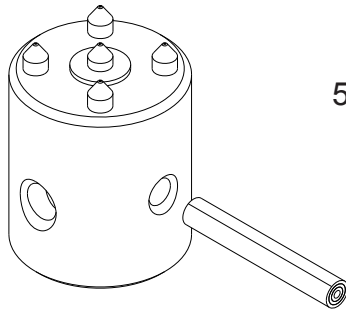

5-POINT TUNGSTEN CARBIDE BIT
WITH COILED SPRING PIN
PART # 18810
5 REQUIRED

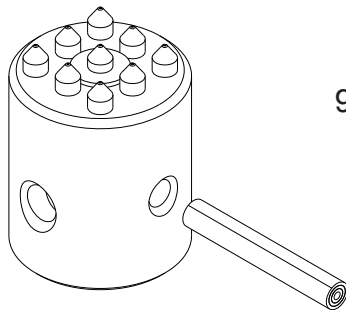

9-POINT TUNGSTEN CARBIDE BIT
WITH COILED SPRING PIN
PART # 18820
5 REQUIRED

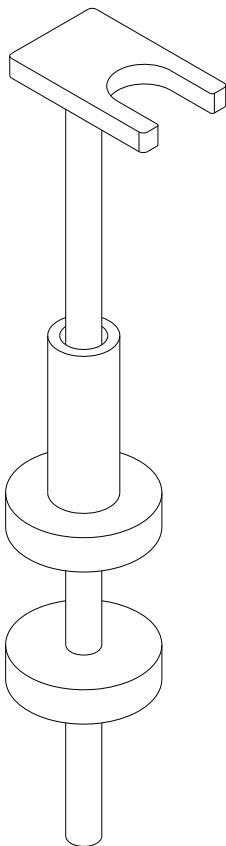

BIT REMOVING TOOL
(SLIDE HAMMER)
PART # 63220

OPTIONAL
(NOT INCLUDED WITH SCABBLER)

LIMITED EQUIPMENT WARRANTY OF SALE – TERMS & CONDITIONS

Equipment Development Company, Inc. herein referred to as EDCO (Seller) warrants that each new unit manufactured by EDCO to be free from defects in material and workmanship in normal use and service for a period of (1) one year (except for the cutter drum assembly on all model concrete/asphalt planes, in which case the warranty period shall be 90 days) from date of shipment to the original retail or equipment rental center owner.

Accessories or equipment furnished and installed on the product by EDCO but manufactured by others, including, but not limited to engines, motors, electrical components, transmissions etc., shall carry the accessory manufacturers own warranty.

EDCO will, at its option, repair or replace, at the EDCO factory or at a point designated by EDCO, any part which shall appear to the satisfaction of EDCO inspection to have been defective in material or workmanship.

EDCO reserves the right to modify, alter and improve any part or parts without incurring any obligation to replace any part or parts previously sold without such modified, altered or improved part or parts.

This warranty is in lieu of and excludes all other warranties, expressed, implied, statutory, or otherwise created under applicable law including, but not limited to the warranty of merchantability and the warranty of fitness for a particular purpose in no event shall seller or the manufacturer of the product be liable for special, incidental, or consequential damages, including loss of profits, whether or not caused by or resulting from the negligence of seller and/or the manufacturer of the product unless specifically provided herein. In addition, this warranty shall not apply to any products or portions thereof of which have been subjected to abuse, misuse, improper installation, maintenance, or operation, electrical failure or abnormal conditions and to products which have been tampered with, altered, modified, repaired, reworked by anyone not approved by seller or used in any manner inconsistent with the provisions of the above or any instructions or specifications provided with or for the product

FORCE MAJEURE

Seller's obligation hereunder are subject to, and Seller shall not be held responsible for, any delay or failure to make delivery of all or any part of the Product due to labor difficulties, fires, casualties, accidents, acts of the elements, acts of God, transportation difficulties, delays by a common carrier, inability to obtain Product, materials or components or qualified labor sufficient to timely perform part of or all of the obligations contained in these terms and conditions, governmental regulations or actions, strikes, damage to or destruction in whole or part of manufacturing plant, riots, terrorist attacks or incidents, civil commotions, warlike conditions, flood, tidal waves, typhoon, hurricane, earthquake, lightning, explosion or any other causes, contingencies or circumstances within or without the United States not subject to the Seller's control which prevent or hinder the manufacture or delivery of the Products or make the fulfillment of these terms and conditions impracticable. In the event of the occurrence of any of the foregoing, at the option of Seller, Seller shall be excused from the performance under these Terms and Conditions, or the performance of the Seller shall be correspondingly extended.

This document sets forth the terms and conditions pursuant to which the purchaser ("Purchaser") will purchase and Equipment Development Co. Inc. ("Seller") will sell the products, accessories, attachments (collectively the Products) ordered by the Purchaser. These terms and conditions shall govern and apply to the sale of Seller's Products to Purchaser, regardless of any terms and conditions appearing on any purchase order or other forms submitted by Purchaser to Seller, or the inconsistency of any terms therein and herein.

1. PRICE

All prices set forth on any purchase order or other document are F.O.B. Sellers facility or distribution point, as may be determined by Seller (F.O.B. Point). All prices are exclusive of any and all taxes, including, but not limited to, excise, sales, use, property or transportation taxes related to the sale or use of the Products, now or hereafter imposed, together with all penalties and expenses. Purchaser shall be responsible for collecting and/or paying any and all such taxes, whether or not they are stated in any invoice for the Products. Unless otherwise specified herein, all prices are exclusive of inland transportation, freight, insurance and other costs and expenses relating to the shipment of the Products from the F.O.B. point to Purchaser's facility. Any prepayment by Seller of freight insurance and other costs shall be for the account of Purchaser and shall be repaid to Seller.

2. PAYMENT TERMS

Payment terms are as follows. 2% 10 days (to approved and qualified accounts). Net 30 days. This is a cash discount for invoices paid within 10 days after the invoice date, regardless of date of receipt of shipment. This is not a trade discount and will not be granted to accounts that do not adhere to stated terms.

*All past due accounts are subject to a late payment fee of 1.5% per month or a maximum allowed by law if different, along with the expenses incidental to collection including reasonable attorney's fees and costs.

*Seller reserves the right to hold shipments against past due accounts.

*Seller reserves the right to alter payment terms.

3. FREIGHT TERMS

All shipments will be made F.O.B. shipping point as designated in these Terms and Conditions, and title shall pass at the F.O.B. point. Delivery to the initial common carrier shall constitute delivery to the Purchaser. Any claims for loss or damage during shipment are to be filed with carrier by the Purchaser. Seller will not assume responsibility for the performance of the carrier.

Back orders will be shipped in the most practical fashion with charges consistent with our freight policy established with the original order. UPS, FED EX, MAIL or shipments by other couriers are subject to the same terms and conditions as outlined in paragraph #3 "Freight Terms".

4. DELIVERY, DAMAGES, SHORTAGES

Seller shall use reasonable efforts to attempt to cause the Products to be delivered as provided for in these Terms & Conditions. Delivery to the initial common carrier shall constitute the delivery to the Purchaser. Seller's responsibility, in so far as transportation risks are concerned ceases upon the delivery of the Products in good condition to such carrier at the F.O.B. point and all the Products shall be shipped at the Purchaser's risk. Seller shall not be responsible or liable for any loss of income and/or profits, or incidental, special, consequential damages resulting from Seller's delayed performance in shipment and delivery.

5. RETURN OF DEFECTIVE PRODUCTS

Defective or failed material shall be held at the Purchaser's premises until authorization has been granted by Seller to return or dispose of Products. Products that are to be returned for final inspection must be returned Freight Prepaid in the most economical way. Credit will be issued for material found to be defective upon Seller's inspection based on prices at time of purchase.

6. PRODUCTS ORDERED IN ERROR

Products may be returned, provided that claim is made and Seller is notified within 7 days of receipt of Products, and the Products are in original buyer's possession not more than 30 days prior to return, subject to Seller's approval. If Products are accepted for return, they must be Freight Prepaid and buyer will be charged a minimum of 15% restocking charge, plus a charge back for outbound freight charges if the original order was shipped prepaid. Returns are not accepted for any Products that are specifically manufactured to meet the buyer's requirement of either specifications or quantity.

AGREEMENTS

These Terms and Conditions constitute the entire agreement between Seller and Purchaser as it relates to terms and conditions of sale, and supersedes any and all prior oral or written agreements, correspondence, quotations or understandings heretofore in force between the parties relating to the subject matter hereof. There are no agreements between Seller and Purchaser with respect to the Product herein except those specifically set forth in and made part of these terms and conditions. Any additional terms, conditions and/or prices are rejected by Seller.

These terms and conditions may be modified, cancelled or rescinded only by a written agreement of both parties executed by their duly authorized agents.

**USE ONLY GENUINE EDCO PARTS & ACCESSORIES
For your own safety, the safety of others and the life of your machine.**

Equipment Development Company, Inc.

