



STARTING SERIAL  
# 181010096

## PARTS LIST MANUAL

# Magna-Trap® 9" Turbo-Lite Grinder



## MODEL TL-9 PART # 58900

**READ AND UNDERSTAND THE OPERATOR'S SAFETY MANUAL THOROUGHLY  
BEFORE ATTEMPTING TO OPERATE THIS EQUIPMENT.**

Death or serious injury could occur if this machine is used improperly.

Machine specific Operator's Instruction Manuals are offered at [edcoinc.com/customer-resources/manuals-parts-lists/](http://edcoinc.com/customer-resources/manuals-parts-lists/)  
READ AND UNDERSTAND THE ENGINE MANUFACTURERS INSTRUCTIONS AND OPERATORS MANUAL BEFORE OPERATION.



**EQUIPMENT DEVELOPMENT COMPANY, INC.**  
100 Thomas Johnson Drive, Frederick, MD 21702-4600 USA  
Phone: 800-638-3326 or 301-663-1600 • Fax: 800-447-3326 or 301-663-1607  
Website: [www.edcoinc.com](http://www.edcoinc.com) • E-mail: [techsupport@edcoinc.com](mailto:techsupport@edcoinc.com)

Printed in USA  
KJK ©2019

**SAFETY INFORMATION****SAFETY MESSAGES**

• Safety Instructions are preceded by a graphic alert symbol of DANGER, WARNING, or CAUTION.



Indicates an imminent hazard which, if not avoided, will result in death or serious injury.



Indicates an imminent hazard which, if not avoided, can result in death or serious injury.



Indicates hazards which, if not avoided, could result in serious injury and or damage to the equipment.

**GASOLINE / PROPANE POWERED EQUIPMENT**

• Engine exhaust from this product contains chemicals known to the State of California to cause cancer, birth defects or other reproductive harm.



• Tilting a gasoline powered machine fitted with an EPA approved vented charcoal filter gas cap, beyond 20° can cause fuel leakage. If a leak occurs, do not start or run the engine until the leak is fixed. Eliminate all other ignition sources in the immediate area (no smoking, flares, sparks or flames). Use approved gasoline absorbing material to contain the fuel leakage. Then use clean, non-sparking tools to collect absorbed materials then dispose of these contaminants properly.



• Gasoline is extremely flammable and poisonous. It should only be dispensed in well ventilated areas, and with a cool engine.

• Small gasoline engines produce high concentrations of carbon monoxide (CO) example: a 5 HP 4 cycle engine operation in an enclosed 100,000 cu. ft. area with only one change of air per hour is capable of providing deadly concentrations of CO in less than fifteen minutes. Five changes of air in the same area will produce noxious fumes in less than 30 minutes. Gasoline powered equipment should not be used in enclosed or partially enclosed areas. Symptoms of CO poisoning include, head-ache, nausea, weakness, dizziness, visual problems and loss of consciousness. If symptoms occur - get into fresh air and seek medical attention immediately.

• Never refuel a hot engine or an engine while it is running.

• Engines are shipped from factory without fuel/oil.



• Propane is extremely flammable and is heavier than air and tends to settle in low areas where a spark or flame could ignite gas. DO NOT start or operate this propane engine in a poorly ventilated area where leaking propane gas could accumulate and endanger safety of persons in area. If headache develops, shut off machine. Have it checked for carbon monoxide emissions by a qualified technician before using it again. To ensure personal safety, installation and repair of propane fuel supply systems must be performed only by qualified technicians. Carbon monoxide emissions from this machine are greatly increased due to a dirty combustion air cleaner.

**ELECTRICAL POWERED EQUIPMENT**

Extreme care must be taken when operating electric models with water present: Ensure power cord is properly grounded, is attached to a Ground-Fault-Interrupter (GFI) outlet, and is undamaged.

- Check all electrical cables - be sure connections are tight and cable is continuous and in good condition. Be sure cable is correctly rated for both the operating current and voltage of this equipment.
- Improper connection of the equipment grounding conductor can result in a risk of electric shock. Check with qualified electrician or service person if there is any doubt as to whether the outlet is properly grounded. Adhere to all local codes and ordinances.
- NOTE: In the event of a malfunction or breakdown, grounding provides a path of least resistance for the electric current to dissipate. The motor is equipped with a grounded plug and must be connected to an outlet that is properly installed and properly grounded. DO NOT modify the plug provided on the motor. If the plug does not fit the outlet have a qualified electrician install the proper receptacle.

**ELECTRICAL POWERED EQUIPMENT CONTINUED**

- Do not disconnect power by pulling cord. To disconnect, grasp the plug, not the cord.
- Unplug power cord at the machine when not in use and before servicing.
- Switch motor OFF before disconnecting power.
- Never use frayed, damaged, taped or under rated extension cords. Electrical shock could result in death or serious injury to the operator and damage to the equipment.
- Assure you are using the proper extension cord length.

**GENERAL INSTRUCTIONS**

- Equipment should only be operated by trained personnel in good physical condition and mental health (not fatigued). The operator and maintenance personnel must be physically able to handle the bulk weight and power of this equipment.
- This is a one person tool. Maintain a safe operating distance to other personnel. It is the operators' responsibility to keep other people (workers, pedestrians, bystanders, etc.) away during operation. Block off the work area in all directions with roping, safety netting, etc. Failure to do so may result in others being injured by flying debris or exposing them to harmful dust and noise.
- This equipment is intended for commercial use only.
- For the operator's safety and the safety of others, always keep all guards in place during operation.
- Never let equipment run unattended.



- Personal Protection Equipment and proper safety attire must be worn when operating this machinery. The operator must wear approved safety equipment appropriate for the job such as hard hat and safety shoes when conditions require. Hearing protection MUST be used when operational noise levels of this equipment may exceed 85db. Eye protection MUST be worn at all times.



Keep body parts, loose clothing and accessories away from moving parts. Failure to do so could result in dismemberment or death.

- Do not modify the machine.
- Stop motor/engine when adjusting or servicing this equipment. Maintain a safe operating distance from flammable materials. Sparks from the cutting-action of this machine can ignite flammable materials or vapors.

**DUST WARNING**

Some dust created by power sanding, sawing, grinding, drilling, and other construction activities contains chemicals known to cause cancer, birth defects, or other reproductive harm. Materials being removed can be toxic or hazardous. A breathing respirator is required to help protect the operator.

Some examples of these chemicals are:

- Lead from lead-based paints.
- Crystalline silica from bricks, concrete and other masonry products. Your risk of exposure to these chemicals varies depending on how often you do this type of work. To reduce your risk: work in a well ventilated area, use a dust control system, such as an industrial-style vacuum, and wear approved personal safety equipment, such as a dust/particle respirator designed to filter out microscopic particles.
- See more on the importance of dust prevention and silica warnings at: [osha.gov/silica](http://osha.gov/silica)
- More concrete and silica dust suppression training and educational materials available at [edcoinc.com/silica-standards](http://edcoinc.com/silica-standards) or scan the QR code on page 5.
- Written exposure plans are provided at <http://www.edcoinc.com/written-exposure-control-plans/>

# PARTS LIST MANUAL

## Magna-Trap® 9” Turbo-Lite Grinder

### MODEL TL-9

#### TABLE OF CONTENTS

<u>Section</u>	<u>Page Number</u>
Safety Messages and General Instructions .....	2
How To Order Replacement Parts .....	3
Illustration 1: Main Grouping .....	4, 5
Illustration 2: Motor & Magna-Trap® Disc Grouping .....	6, 7
Illustration 3: Fork Grouping .....	8
Wiring Diagram .....	9
Decal Sheet .....	10
Notes .....	11
Limited Equipment Warranty of Sale - Terms & Conditions .....	12 (Back Page)

#### HOW TO ORDER REPLACEMENT PARTS

- To insure product safety and reliability, always use genuine EDCO replacement parts when making repairs to the equipment.
- When calling for parts, specify the MODEL and SERIAL number of the machine, which can be found on the NAME PLATE. Keep that information in the space provided. In addition to this information, give part number, description, and quantity as listed on the parts list to your parts representative.
- Please note: Due to improvements and changes in the equipment, the illustrations shown may be different than the actual machine.

#### FILL IN INFORMATION BELOW

Date of Purchase \_\_\_\_\_

Model # \_\_\_\_\_

Serial # \_\_\_\_\_

SKU # \_\_\_\_\_



### EQUIPMENT DEVELOPMENT COMPANY, INC.

100 Thomas Johnson Drive, Frederick, MD 21702-4600 USA  
 Phone: 800-638-3326 or 301-663-1600 • Fax: 800-447-3326 or 301-663-1607  
 Website: www.edcoinc.com • E-mail: techsupport@edcoinc.com

Printed in USA

KJK ©2019

ILLUSTRATION 1: MAIN GROUPING

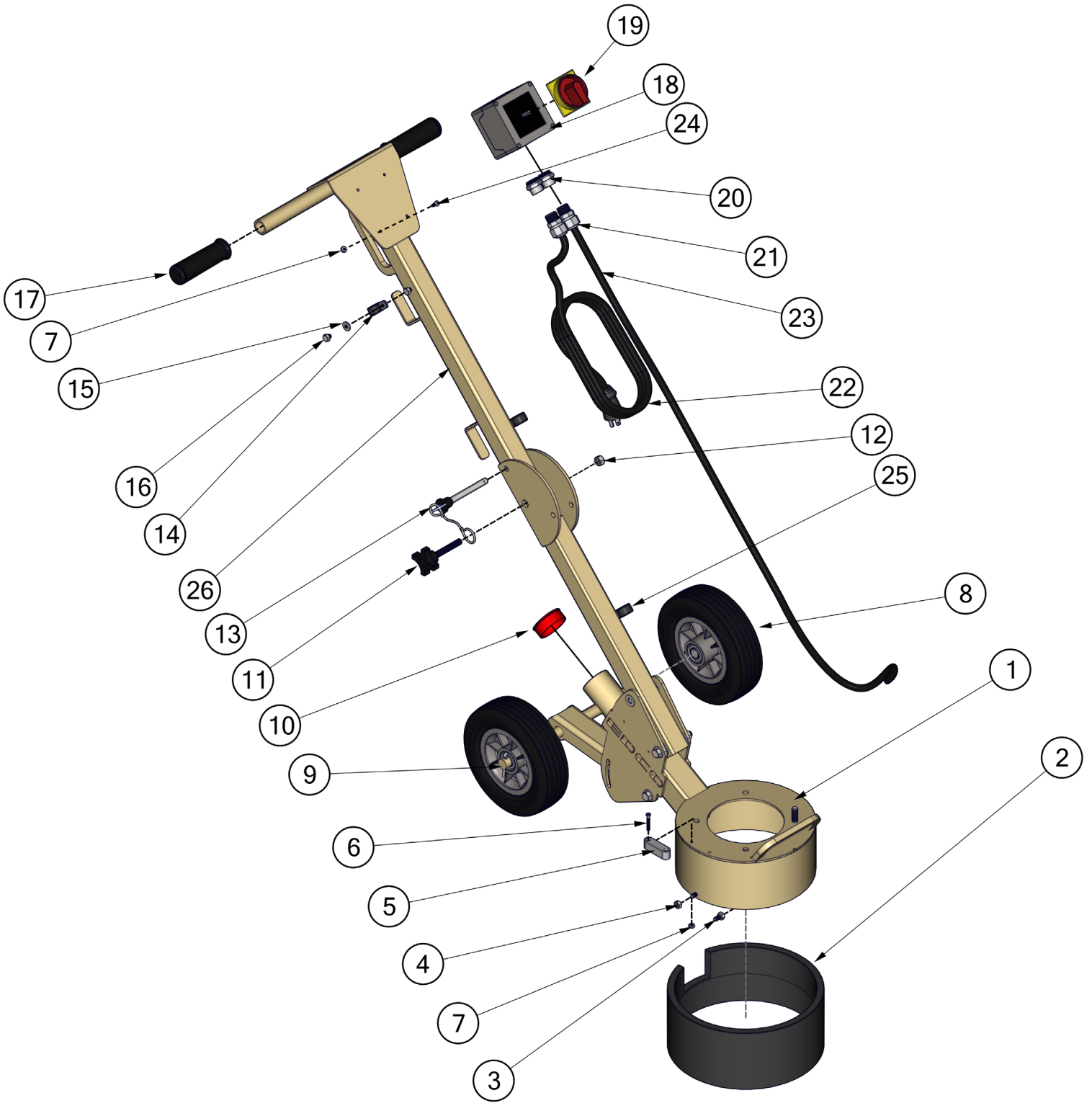

<b>PARTS LISTING - ILLUSTRATION 1 : MAIN GROUPING</b>			
<b>ITEM #</b>	<b>PART #</b>	<b>DESCRIPTION</b>	<b>QTY.</b>
1	58950	MAIN FRAME, TL-9	1
2	58956	DUST RING, TL-9	1
3	10834	SCREW, CAP 1/4-20 X 1/2 ZINC	2
4	10861	NUT, KEPS LOCK 1/4-20 ZINC	2
5	59117	LEVEL, SCREW ON	1
6	11871	SCREW, MACHINE FHP 8-32 X 1-1/4	2
7	10462	NUT, KEPS LOCK 8-32 ZINC	6
8	79013	WHEEL, 8 X 2-1/2 X 3/4"BRG.POLY HUB	2
9	10306	PIN, COTTER 3/16 X 1-1/2	2
10	65021	CAP/PLUG 2" RED PLASTIC, FLANGED	1
11	58963	FOUR ARM KNOB, 3/8-16 X 2-1/2, TL-9	1
12	10810	NUT, HEX LOCK 3/8-16 ZINC	1
13	58959	QUICK RELEASE PIN W/ LANYARD, TL-9	1
14	11690	CLAMP, LOOM, 3/8"	1
15	10038	WASHER, LOCK 1/4 ZINC	3
16	10846	SCREW, CAP STSHW 1/4-20 X 1/2	3
17	10608	GRIP, HAND 1" MODEL AT	2
18	77043	SWITCH, ROTARY CAM ON/OFF, LOVATO (INCLUDES #19) <u>REPLACEMENT PARTS:</u> .....GASKET RING, OPERATOR, LOVATO	1
	77043-4.....		
19	77043-2	SWITCH HANDLE, PADLOCKABLE, LOVATO	1
20	77043-1	SWITCH ADAPTER, PG16 TO 1/2"NPT	2
21	40066	STRAIN RELIEF 1/2NPT X .350-.450"	2
22	86422	CORD W/ PLUG, 25FT. POWER, STRAIGHT STYLE PLUG	1
23	58964	MOTOR CORD 12/3 AWG SJ00W X 56"	1
24	11663	SCREW, MACHINE 8-32 X 1/2 RHCD ZINC (INSIDE OF ITEM 18)	4
25	11565	CLAMP, LOOM 5/8"	2
26	58953	UPPER HANDLE, TL9	1

**EQUIPMENT DEVELOPMENT COMPANY, INC.**

100 Thomas Johnson Drive, Frederick, MD 21702-4600 USA  
 Phone: 800-638-3326 or 301-663-1600 • Fax: 800-447-3326 or 301-663-1607  
 Website: www.edcoinc.com • E-mail: techsupport@edcoinc.com

Printed in USA

KJK ©2019

**Page 5**

**ILLUSTRATION 2: MOTOR & MAGNA-TRAP® DISC GROUPING**

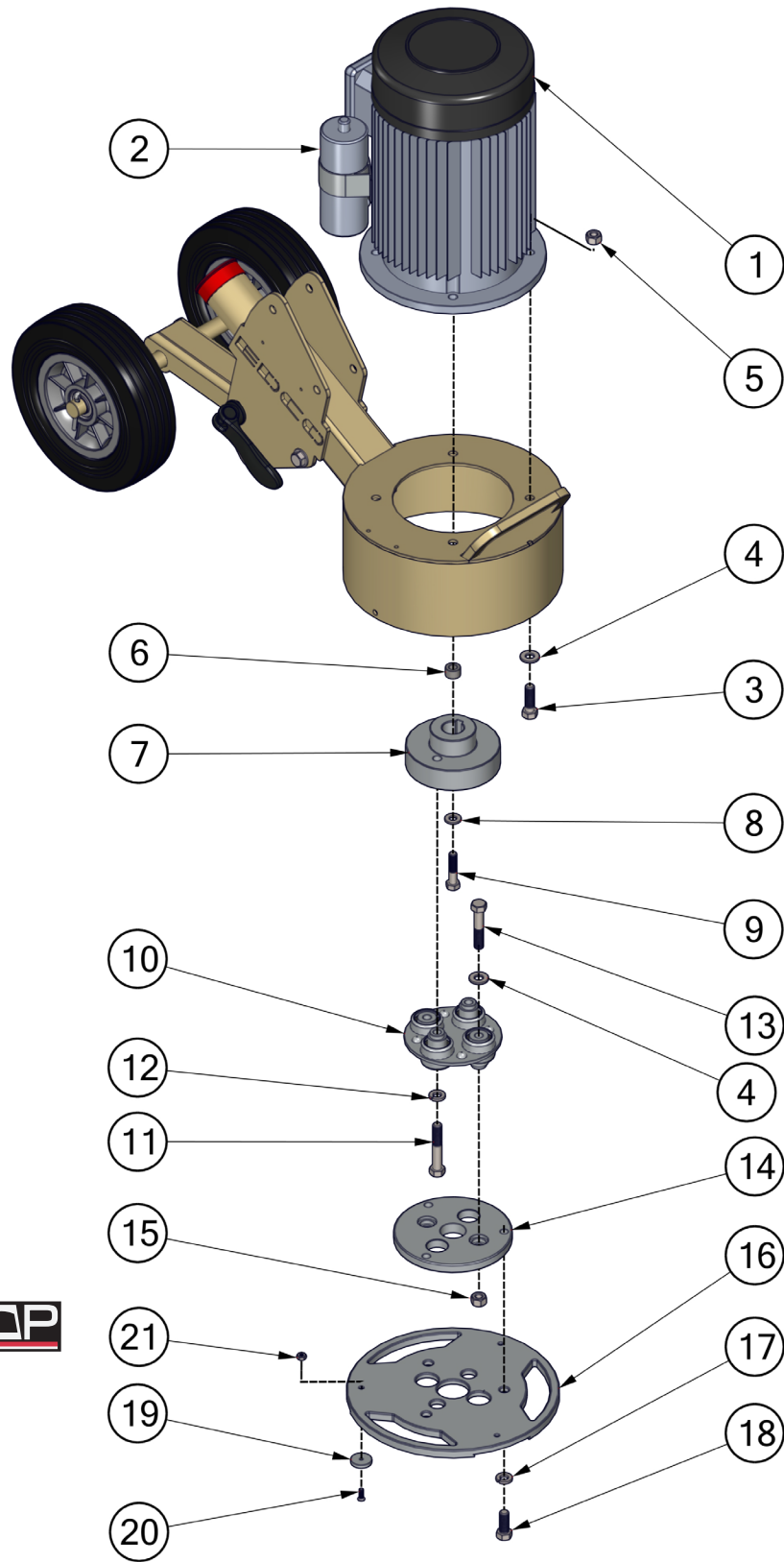

**PARTS LISTING - ILLUSTRATION 2:****MOTOR & MAGNA-TRAP® DISC GROUPING**

ITEM #	PART #	DESCRIPTION	QTY.
1	16091	MOTOR, EMGR 1.1KW 115V 60HZ, TL-9	1
	28506	STRAIN RELIEF, M20X1.5 .276-.512"	2
2	58961	CAPACITOR, START, EMGR MOTOR	2
	58962	LOOM CLAMP FOR CAPACITOR	2
3	10333	SCREW, CAP 3/8-16 X 1-1/4	4
4	10025	WASHER, FLAT 3/8 SAE ZINC	6
5	10156	NUT, HEX NYLON LOCK 3/8-16 ZINC	6
6	10011	SPACER, STEEL 5/8OD X 3/8ID X 3/8T	1
7	58954	HEAD BRACKET, TL-9	1
8	10213	WASHER, LOCK 5/16 SAE ZINC	1
9	11775	SCREW, CAP M8-1.25 X 40MM	1
10	86017	COUPLING, MORFLEX 402 CENTER	1
11	58967	SCREW, CAP 3/8-16 X 2-1/4 GR. 8	2
12	10811	WASHER, LOCK 3/8 ZINC	2
13	58968	SCREW, CAP 3/8-16 X 2 GR. 8	2
14	58955	TOOL BRACKET, TL-9	1
15	10810	NUT, HEX LOCK 3/8-16 ZINC	2
16	58903	9" MAGNA-TRAP DISC W/ MAGNETS, TL-9 INCLUDES ITEMS (16,19,20,21)	1
17	10453	WASHER, LOCK, INT. TOOTH 3/8"	3
18	10907	SCREW, CAP 3/8-16 X 3/4	3
19	36064	MAGNET, NEODYMIUM RING 7/8 X 1/8	3
20	10647	SCREW, FLAT HD PHILLIPS 8-32 X 1/2	3
21	10462	NUT, KEPS LOCK 8-32 ZINC	3

**EQUIPMENT DEVELOPMENT COMPANY, INC.**

100 Thomas Johnson Drive, Frederick, MD 21702-4600 USA  
 Phone: 800-638-3326 or 301-663-1600 • Fax: 800-447-3326 or 301-663-1607  
 Website: www.edcoinc.com • E-mail: techsupport@edcoinc.com

Printed in USA

KJK ©2019

**Page 7**

**ILLUSTRATION 3: FORK GROUPING**

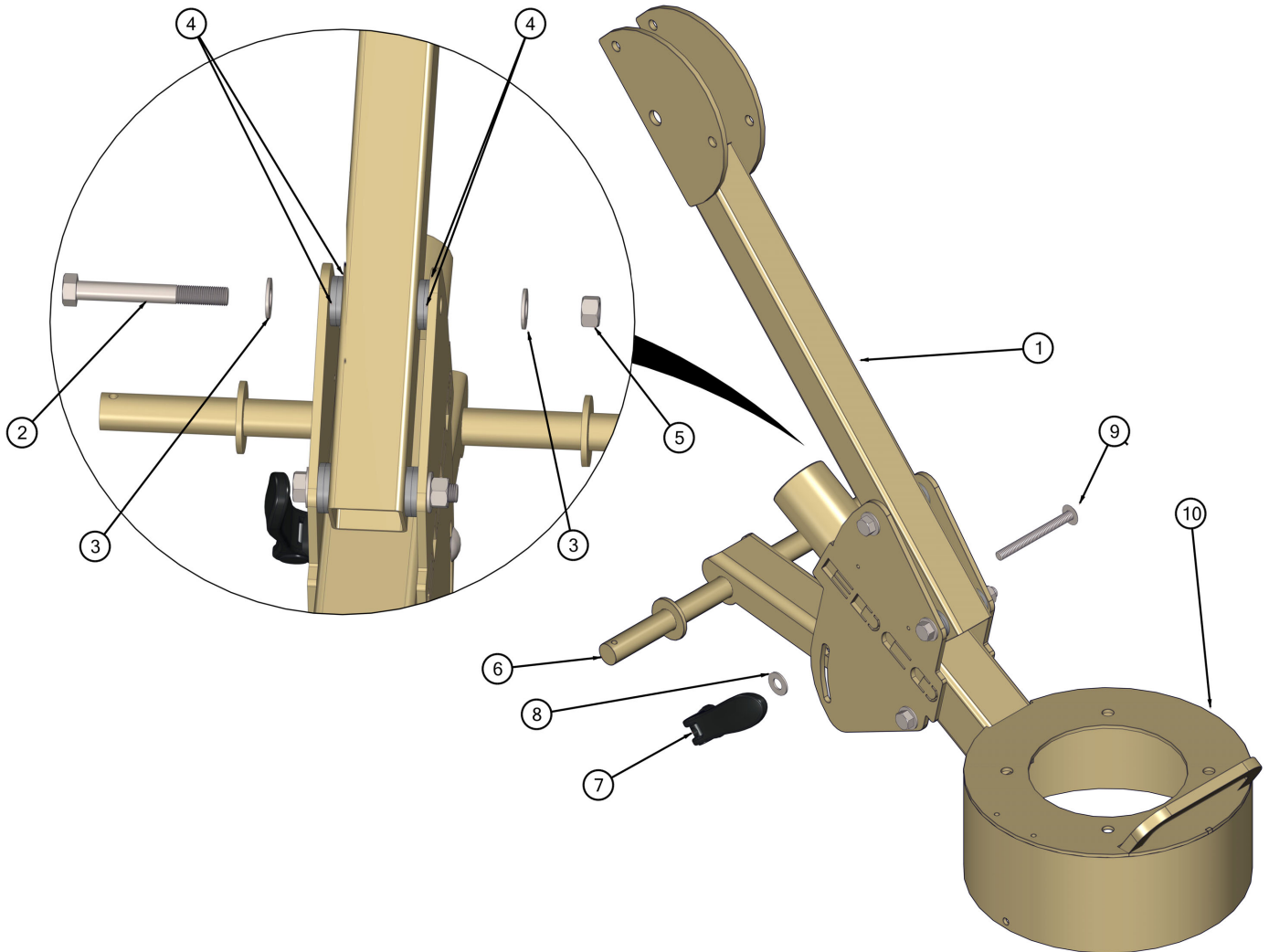

PARTS LISTING - ILLUSTRATION 2:			
MOTOR & MAGNA-TRAP® DISC GROUPING			
ITEM #	PART #	DESCRIPTION	QTY.
1	58952	LOWER HANDLE, TL-9	1
2	10855	SCREW, CAP 3/8-24 X 3	3
3	10025	WASHER, FLAT 3/8 SAE ZINC	6
4	11695	WASHER, 1.121 X .375 X .128	8
5	10152	NUT, HEX LOCK 3/8-24 ZINC	3
6	58951	REAR AXLE, TL-9	1
7	58969	CAM LEVER, HANDLE 5/16-18 TL-9	1
8	58970	WASHER, BELLEVILLE 5/16	1
9	58971	BOLT, CARRIAGE 5/16-18 X 3-1/4	1



# WIRING DIAGRAM

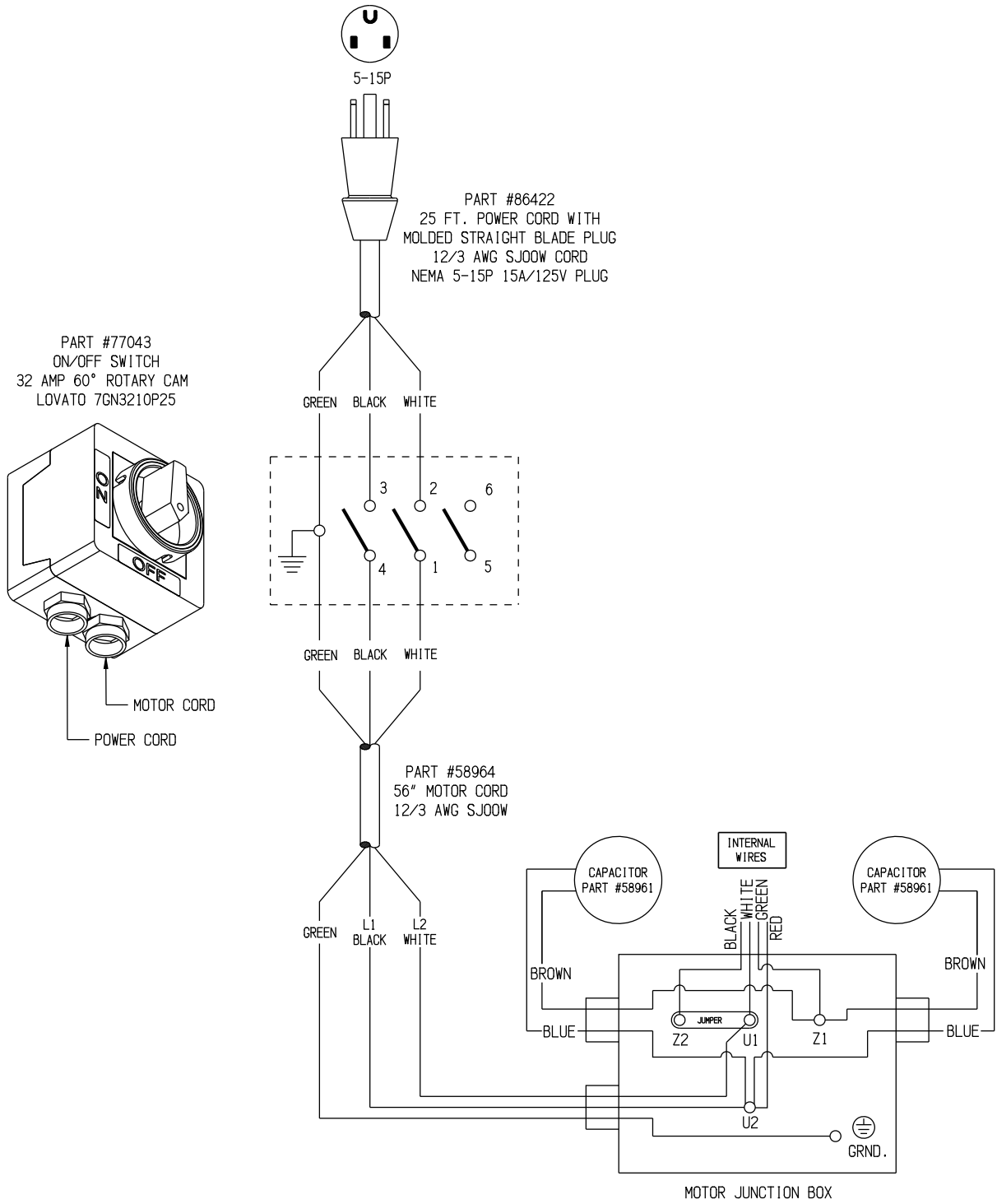

DECAL SHEET

P/N 92231 RevE

TL-9

11 x 14



RENTAL-TOUGH

MAX EXT. CORD 25 FT, 10 GAUGE



exceeds 85dBA

SWITCH & MOTOR

115 VOLTS

SINGLE PHASE

220 VOLTS

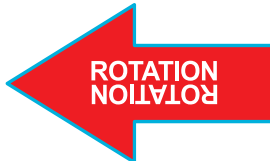



## LIMITED EQUIPMENT WARRANTY OF SALE - TERMS & CONDITIONS

Equipment Development Company, Inc. herein referred to as EDCO (Seller) warrants that each new unit manufactured by EDCO to be free from defects in material and workmanship in normal use and service for a period of (1) one year (except for the cutter drum assembly on all model concrete/asphalt planers AND the chisel head assembly on all model ALR's & ALR-BS in which case the warranty period shall be 90 days) from date of shipment to the original retail or equipment rental center owner.

Accessories or equipment furnished and installed on the product by EDCO but manufactured by others, including, but not limited to engines, motors, electrical components, transmissions etc., shall carry the accessory manufacturers own warranty.

EDCO will, at its option, repair or replace, at the EDCO factory or at a point designated by EDCO, any part which shall appear to the satisfaction of EDCO inspection to have been defective in material or workmanship.

EDCO reserves the right to modify, alter and improve any part or parts without incurring any obligation to replace any part or parts previously sold without such modified, altered or improved part or parts.

This warranty is in lieu of and excludes all other warranties, expressed, implied, statutory, or otherwise created under applicable law including, but not limited to the warranty of merchantability and the warranty of fitness for a particular purpose in no event shall seller or the manufacturer of the product be liable for special, incidental, or consequential damages, including loss of profits, whether or not caused by or resulting from the negligence of seller and/or the manufacturer of the product unless specifically provided herein. In addition, this warranty shall not apply to any products or portions thereof which have been subjected to abuse, misuse, improper installation, maintenance, or operation, electrical failure or abnormal conditions and to products which have been tampered with, altered, modified, repaired, reworked by anyone not approved by seller or used in any manner inconsistent with the provisions of the above or any instructions or specifications provided with or for the product.

### FORCE MAJEURE

Seller's obligation hereunder are subject to, and Seller shall not be held responsible for, any delay or failure to make delivery of all or any part of the Product due to labor difficulties, fires, casualties, accidents, acts of the elements, acts of God, transportation difficulties, delays by a common carrier, inability to obtain Product, materials or components or qualified labor sufficient to timely perform part of or all of the obligations contained in these terms and conditions, governmental regulations or actions, strikes, damage to or destruction in whole or part of manufacturing plant, riots, terrorist attacks or incidents, civil commotions, warlike conditions, flood, tidal waves, typhoon, hurricane, earthquake, lightning, explosion or any other causes, contingencies or circumstances within or without the United States not subject to the Seller's control which prevent or hinder the manufacture or delivery of the Products or make the fulfillment of these terms and conditions impracticable. In the event of the occurrence of any of the foregoing, at the option of Seller, Seller shall be excused from the performance under these Terms and Conditions, or the performance of the Seller shall be correspondingly extended.

This document sets forth the terms and conditions pursuant to which the purchaser ("Purchaser") will purchase and Equipment Development Co. Inc. ("Seller") will sell the products, accessories, attachments (collectively the Products) ordered by the Purchaser. These terms and conditions shall govern and apply to the sale of Seller's Products to Purchaser, regardless of any terms and conditions appearing on any purchase order or other forms submitted by Purchaser to Seller, or the inconsistency of any terms therein and herein.

### 1. PRICE

All prices set forth on any purchase order or other document are F.O.B. Seller's facility or distribution point, as may be determined by Seller (F.O.B. Point). All prices are exclusive of any and all taxes, including, but not limited to, excise, sales, use, property or transportation taxes related to the sale or use of the Products, now or hereafter imposed, together with all penalties and expenses. Purchaser shall be responsible for collecting and/or paying any and all such taxes, whether or not they are stated in any invoice for the Products. Unless otherwise specified herein, all prices are exclusive of inland transportation, freight, insurance and other costs and expenses relating to the shipment of the Products from the F.O.B. point to Purchaser's facility. Any prepayment by Seller of freight insurance and other costs shall be for the account of Purchaser and shall be repaid to Seller.

### 2. PAYMENT TERMS

Payment terms are as follows. 2% 10 days (to approved and qualified accounts). Net 30 days. This is a cash discount for invoices paid within 10 days after the invoice date, regardless of date of receipt of shipment. This is not a trade discount and will not be granted to accounts that do not adhere to stated terms.

\*All past due accounts are subject to a late payment fee of 1.5% per month or a maximum allowed by law if different, along with the expenses incidental to collection including reasonable attorney's fees and costs.

\*Seller reserves the right to hold shipments against past due accounts.

\*Seller reserves the right to alter payment terms.

### 3. FREIGHT TERMS

All shipments will be made F.O.B. shipping point as designated in these Terms and Conditions, and title shall pass at the F.O.B. point. Delivery to the initial common carrier shall constitute delivery to the Purchaser. Any claims for loss or damage during shipment are to be filed with carrier by the Purchaser. Seller will not assume responsibility for the performance of the carrier.

Back orders will be shipped in the most practical fashion with charges consistent with our freight policy established with the original order. UPS, FED EX, MAIL or shipments by other couriers are subject to the same terms and conditions as outlined in paragraph #3 "Freight Terms".

### 4. DELIVERY, DAMAGES, SHORTAGES

Seller shall use reasonable efforts to attempt to cause the Products to be delivered as provided for in these Terms & Conditions. Delivery to the initial common carrier shall constitute the delivery to the Purchaser. Seller's responsibility, in so far as transportation risks are concerned ceases upon the delivery of the Products in good condition to such carrier at the F.O.B. point and all the Products shall be shipped at the Purchaser's risk. Seller shall not be responsible or liable for any loss of income and/or profits, or incidental, special, consequential damages resulting from Seller's delayed performance in shipment and delivery.

### 5. RETURN OF DEFECTIVE PRODUCTS

Defective or failed material shall be held at the Purchaser's premises until authorization has been granted by Seller to return or dispose of Products. Products that are to be returned for final inspection must be returned Freight Prepaid in the most economical way. Credit will be issued for material found to be defective upon Seller's inspection based on prices at time of purchase.

### 6. PRODUCTS ORDERED IN ERROR

Products may be returned, provided that claim is made and Seller is notified within 7 days of receipt of Products, and the Products are in original buyer's possession not more than 30 days prior to return, subject to Seller's approval. If Products are accepted for return, they must be Freight Prepaid and buyer will be charged a minimum of 15% restocking charge, plus a charge back for outbound freight charges if the original order was shipped prepaid. Returns are not accepted for any Products that are specifically manufactured to meet the buyer's requirement of either specifications or quantity.

### AGREEMENTS

These Terms and Conditions constitute the entire agreement between Seller and Purchaser as it relates to terms and conditions of sale, and supersedes any and all prior oral or written agreements, correspondence, quotations or understandings heretofore in force between the parties relating to the subject matter hereof. There are no agreements between Seller and Purchaser with respect to the Product herein except those specifically set forth in and made part of these terms and conditions. Any additional terms, conditions and/or prices are rejected by Seller.

These terms and conditions may be modified, cancelled or rescinded only by a written agreement of both parties executed by their duly authorized agents.

**USE ONLY GENUINE EDCO PARTS & ACCESSORIES**  
**For your own safety, the safety of others and the life of your machine.**

**SUBMIT ALL WARRANTY CLAIMS AT:**

[edcoinc.com/customer-support/warranty-claim-form/](http://edcoinc.com/customer-support/warranty-claim-form/)