

REVISED STARTING  
SERIAL # 060110202

# PARTS LIST MANUAL

## 8" WALK BEHIND SCARIFIER



**MODEL  
CPM8-9H  
SHOWN**

### CPM8 SCARIFIERS

SKU NO.	MODEL	POWER OPTIONS
79300	CPM8-9H	9 HP HONDA GX270 GASOLINE ENGINE
79500	CPM8-5B/230/1	5 HP BALDOR 1-PHASE, 230V, 19.5 FLA ELECTRIC MOTOR
79400-230	CPM8-5B/230/3	5 HP BALDOR 3-PHASE, 230V, 12 FLA ELECTRIC MOTOR
79400-460	CPM8-5B/460/3	5 HP BALDOR 3-PHASE, 460V, 6 FLA ELECTRIC MOTOR



100 Thomas Johnson Drive, Frederick, MD 21702-4600 USA  
Phone (301) 663-1600 • 1-800-638-3326  
Fax (301) 663-1607 • 1-800-447-3326  
Website: [www.edcoinc.com](http://www.edcoinc.com) • Email: [sales@edcoinc.com](mailto:sales@edcoinc.com)

Printed in USA  
NAA ©2006

READ AND UNDERSTAND THE OPERATORS INSTRUCTION MANUAL THOROUGHLY BEFORE ATTEMPTING TO OPERATE THIS EQUIPMENT. Death or serious injury could occur if this machine is used improperly.



## SAFETY MESSAGES



The safety instructions are preceded by a graphic alert message of DANGER, WARNING, or CAUTION.



Indicates an imminent hazard which, if not avoided, will result in death or serious injury.



Indicates an imminent hazard which, if not avoided, can result in death or serious injury.



Indicates hazards which, if not avoided, could result in serious injury and or damage to the equipment.

## GASOLINE Powered Equipment



- Do not operate gasoline powered equipment without adequate ventilation. Carbon monoxide is an invisible, odorless gas that can kill.

## ELECTRICAL Powered Equipment



- ELECTRICAL HAZARD** - Be sure equipment is properly grounded. Failure to comply could kill or result in serious injury.



The engine exhaust from this product contains chemicals known to the State of California to cause cancer, birth defects or other reproductive harm.

## GENERAL INSTRUCTIONS



- You must read and understand the operators instruction manual and all other manuals associated with this machine. For your safety and the safety of others around you, it is extremely important to fully understand how to operate this machine in the way it was intended. Different model machines or older/newer versions of the same model may have different parts and controls that you need to understand. If instructions are not readable or available DO NOT USE this machine and contact the factory for a replacement Manual.
- You must be able to physically handle the bulk weight and power of this machine. If not properly controlled this machine can cause death or serious injury.
- Do not operate this machine in an impaired mental state. You must be able to exercise good judgement and reactions to maintain a safe working environment.
- This is a "one person" machine which means only one operator can be operating the machine at any one time. For the safety of others, maintain a safe operating distance to other personnel. Your work area should be defined and appropriately marked so bystanders and coworkers do not stand or walk near this machine and end up seriously injured by flying debris or exposing them to harmful noise or dust.
- This equipment is for Commercial use. Although this is a "one person" machine your work team should understand how to shut this machine off and quickly get medical help if an accident strikes the operator.
- Keep all guards in place during operation. The guards are to provide protection from inadvertent contact with dangerous moving parts, pinch points, or hot surfaces.
- Wear appropriate Personal Protective Equipment (PPE) including safety glasses, safety boots, work gloves, respiratory protection, hearing protection, and head protection. Do not wear loose clothing that can get tangled in moving parts. Failure to do so could result

in dismemberment or death. **Wear an approved respirator when removing hazardous materials or when grinding/cutting dry materials. Some dust particles such as concrete dust can contain silicate particles which can cause silicosis (a very serious lung disease). Contact NIOSH or OSHA for further details. When wet grinding/cutting, avoid contact with the concrete/asphalt slurry which can cause serious skin irritations.**

- You must maintain this machine per the maintenance schedule in the operator manual. Remember before adjusting, servicing, or fueling this machine, disconnect the source of power to the machine by disconnecting the spark plug (Gas models), or by unplugging the electrical power cord (electric models) or air hose (Pneumatic models) AT THE MACHINE so you can assure yourself it remains unplugged while you are working on it. Do not modify this machine. Use only genuine EDCO parts and accessories. Repairs and service should be performed by approved EDCO dealers or authorized technicians.
- You should look carefully around the area before you begin work so you can identify potential hazards such as deck inserts, pipes, columns, openings, electrical cords or outlets, or any other objects protruding from the slab surface.
- This machine has no brain so you must use your own. There is no substitute for safety. The safety decals on the machine are to serve as a reminder for information you must already know before you begin using this machine. Take a moment to reread the safety decals each time you use the machine. If your machine is missing any decals, contact the factory for a replacement (EDCO 1-800-638-3326).

# PARTS LIST MANUAL

## MODEL CPM-8

<u>Section</u>	<u>Page Number</u>
Safety Messages / General Instructions. . . . .	2
How To Order Replacement Parts. . . . .	3
Illustration 1 : Frame Grouping . . . . .	4,5
Illustration 2 : Drum Shaft & Bearing Grouping . . . . .	6
Illustration 3 : Engine & Belt Drive Grouping . . . . .	7
Illustration 4 : Motor & Belt Drive Grouping . . . . .	8,9
Illustration 5 : Cutter Drum Assembly . . . . .	10
Illustration 6 : Diamond Grooving Head Assembly . . . . .	11
Illustration 7 : Optional Edger Assembly . . . . .	12
Illustration 8 : Edger Cutter Drum Assembly . . . . .	13
Illustration 9 : Optional Shaft Cover Kit . . . . .	14
Blank . . . . .	15
Limited Equipment Warranty . . . . .	back cover

### HOW TO ORDER REPLACEMENT PARTS

- To insure product safety and reliability, always use genuine EDCO replacement parts when making repairs to the equipment.
- When calling for parts, specify the MODEL and SERIAL NUMBER of the machine which can be found on the NAME PLATE. Keep that information in the space provided. In addition to this information, give part number, description and quantity as listed on the parts list to your parts representative.
- Please note: Due to improvements and changes in the equipment, the illustrations shown may be different than the actual machine.

### FILL IN INFORMATION BELOW

Date of Purchase \_\_\_\_\_

Name of Machine \_\_\_\_\_

Model # \_\_\_\_\_

Serial # \_\_\_\_\_

Belt Size(s) \_\_\_\_\_

Toll Free: 1-800-638-3326

FAX: 1-800-447-3326

email: sales@edcoinc.com

www.edcoinc.com



100 Thomas Johnson Drive, Frederick, MD 21702-4600 USA

Phone (301) 663-1600 • 1-800-638-3326

Fax (301) 663-1607 • 1-800-447-3326

Website: www.edcoinc.com • Email: sales@edcoinc.com

Printed in USA

NAA ©2006

**Page 3**

# ILLUSTRATION 1: FRAME GROUPING

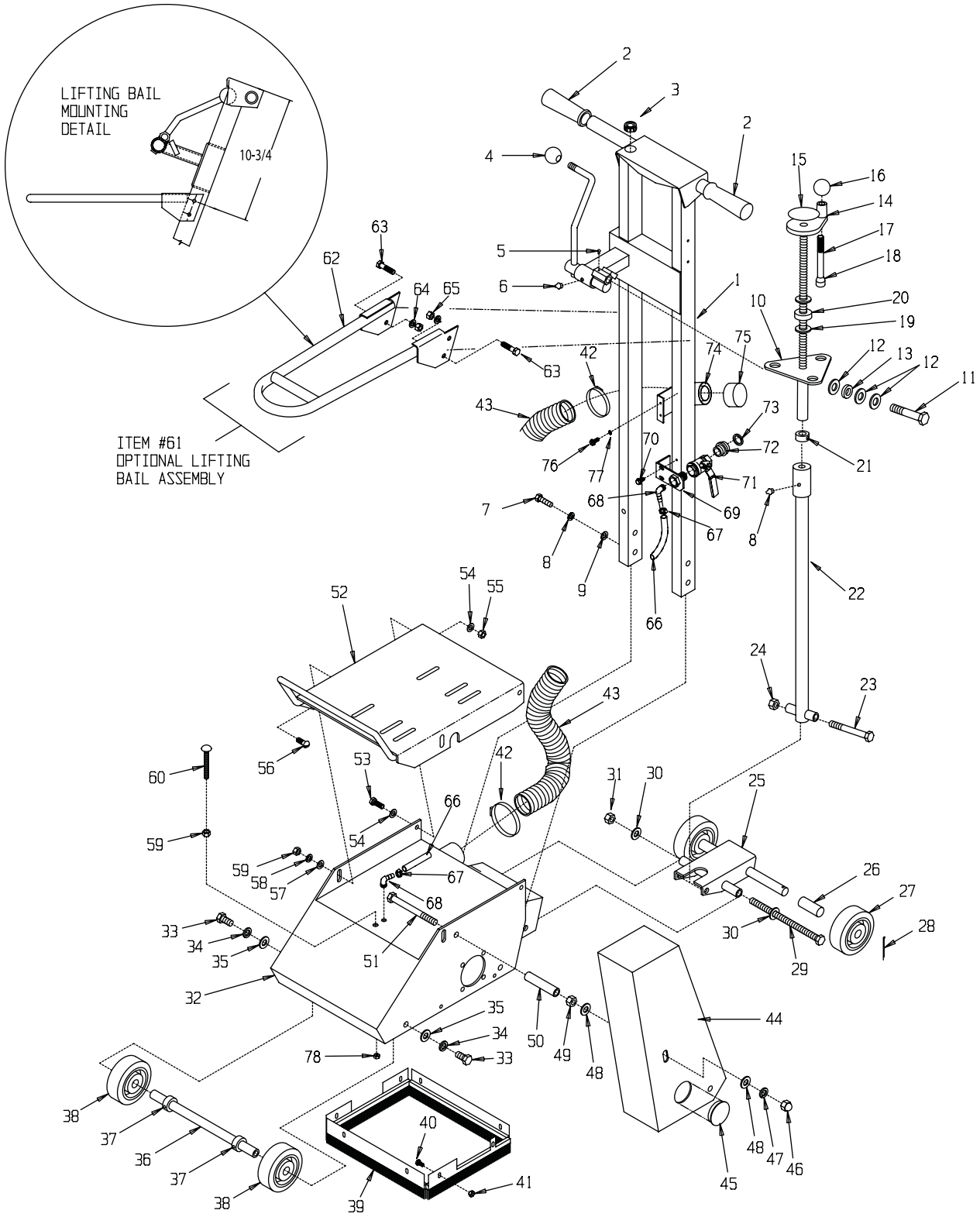

**PARTS LISTING - ILLUSTRATION 1: FRAME GROUPING**

ITEM#	PART#	DESCRIPTION	QTY.	ITEM#	PART#	DESCRIPTION	QTY.
1	65009	HANDLE BAR	1	39	65036	BRUSHES (SET OF 4)	1
2	10608	GRIP, HAND 1' MODEL AT	2	40	10834	SCREW, CAP 1/4-20 x 1/2	8
3	10005	PLUG, HOLE 7/8 (CHROME) - ELEC. MODELS ONLY	1	41	10861	NUT, KEPS 1/4-20	8
4	14023	KNOB, BALL 1-3/8"DIA w/ 1/2-13 THD.	1	42	10745	CLAMP, HOSE, SAE # 32 ADJ. to 2-1/2"	2
5	10127	SCREW, DRIVE 1/8 x 1/4 L	1	43	65098	HOSE, FLEX 2" ID x 22" L	1
6	10808	FITTING, GREASE 1/4-28 STRAIGHT	2	44	65003	COVER, BELT	1
7	10055	SCREW, CAP 3/8-16 x 1	4	45	65022	PLUG, HOLE 2"	1
8	10811	WASHER, LOCK 3/8	4	46	10422	NUT, ACORN 1/2-20	2
9	10025	WASHER, FLAT 3/8	4	47	10045	WASHER, LOCK 1/2	2
10	65007	LINKAGE SUPPORT, UPPER	1	48	10312	WASHER, FLAT 1/2	4
11	10359	SCREW, CAP 5/8-11 x 3-1/4	1	49	10072	NUT 1/2-20	2
12	10073	WASHER, FLAT 5/8	3	50	65016	SPACER, TUBE 1/2 ID x 3-9/16L	2
13	79035	BUSHING, RUBBER 5/8 ID x 1/4 THK	1	51	65017	SCREW, CAP 1/2-20 x 5	1
14	65019	HANDWHEEL, SMALL w/ 5/8-8 x 13" ROD	1	52	65002	MOUNT, ENGINE/MOTOR	1
15	80007	DECAL, DEPTH STOP, DN/UP (SMALL ROUND)	1	53	10021	SCREW, CAP 3/8-24 x 1	2
16	14023	KNOB, BALL 1-3/8 DIA. w/ 1/2-13 THD.	1	54	10025	WASHER, FLAT 3/8	4
17	10411	SCREW, SKT. HD. CAP 1/2-13 x 4	1	55	10004	NUT, LOCK 3/8-24	2
18	50550	SLEEVE for 1/2" CAPSCREW, TAPERED	1	56	10802	BOLT, CARRIAGE 3/8-16 x 1	2
19	10073	WASHER, FLAT 5/8	1	57	10025	WASHER, FLAT 3/8	4
20	85005	BEARING, THRUST BALL 5/8 ID x 1-1/2 OD	1	58	10811	WASHER, LOCK 3/8	4
21	10096	COLLAR, LOCKING 5/8 ID	1	59	10404	NUT 3/8-16	3
22	65006	LINKAGE, LOWER	1	60	10388	BOLT, CARRIAGE 3/8-16 x 3 FULL THREAD	1
23	81001	SCREW, CAP 1/2-13 x 4	1	61	65096A	BAIL ASSEMBLY, LIFTING (ITEMS 62-65)	1
24	10407	NUT, LOCK 1/2-13	1	62	65096	BAIL ONLY, LIFTING	1
25	65004	FORK	1	63	10816	SCREW, CAP 3/8-24 x 1-1/2	4
26	65005	SPACER, REAR WHEEL 2-1/8	2	64	10811	WASHER, LOCK 3/8	4
27	52001	WHEEL, 4 x 1-1/2 x 3/4 BRG. ALUM./ RUBBER	2	65	10014	NUT 3/8-24	4
28	10306	PIN, COTTER 3/16 x 1-1/4	2	66	65089	HOSE, WATER 3/8 ID x 19-1/4 L	1
29	65015	SCREW, CAP 1/2-13 x 8	1	67	50069	CLAMP, HOSE, SAE #6 ADJ. to 13/16	2
30	10312	WASHER, FLAT 1/2	2	68	11562	BARB. ELBOW 90°, 3/8 HOSE x 1/8 MPT	1
31	10407	NUT, LOCK 1/2-13	1	69	56022	BRACKET, WATER VALVE	1
32	65001	MAIN FRAME	1	70	10846	SCREW, STSHW 1/4-20 x 1/2	2
33	10304	SCREW, CAP 1/2-20 x 1	2	71	10711	VALVE, BALL 1/2 FPT	1
34	10045	WASHER, LOCK 1/2	2	72	80021	CONNECTOR, SWIVEL, FEMALE 3/4 HOSE x 1/2 MPT (INCL. #73)	1
35	10312	WASHER, FLAT 1/2	2	73	10070	WASHER, HOSE 3/4	1
36	65014	AXLE SHAFT, FRONT 3/4 DIA. x 12-7/32 L	1	74	86347	BRACKET, MULTI-VAC PORT	1
37	10428	COLLAR, LOCKING 3/4 ID	2	75	64030	PLUG, CAP 3" TUBE	1
38	52001	WHEEL, 4 x 1-1/2 x 3/4 BRG. ALUM./RUBBER	2	76	10846	SCREW, CAP STSHW 1/4-20 x 1/2	2
				77	10038	WASHER, LOCK 1/4	4
				78	10864	NUT 1/8-27 PIPE THREAD	1



100 Thomas Johnson Drive, Frederick, MD 21702-4600 USA

Phone (301) 663-1600 • 1-800-638-3326

Fax (301) 663-1607 • 1-800-447-3326

Website: www.edcoinc.com • Email: sales@edcoinc.com

Printed in USA

NAA ©2006

**Page 5**

## ILLUSTRATION 2: DRUM SHAFT & BEARING GROUPING

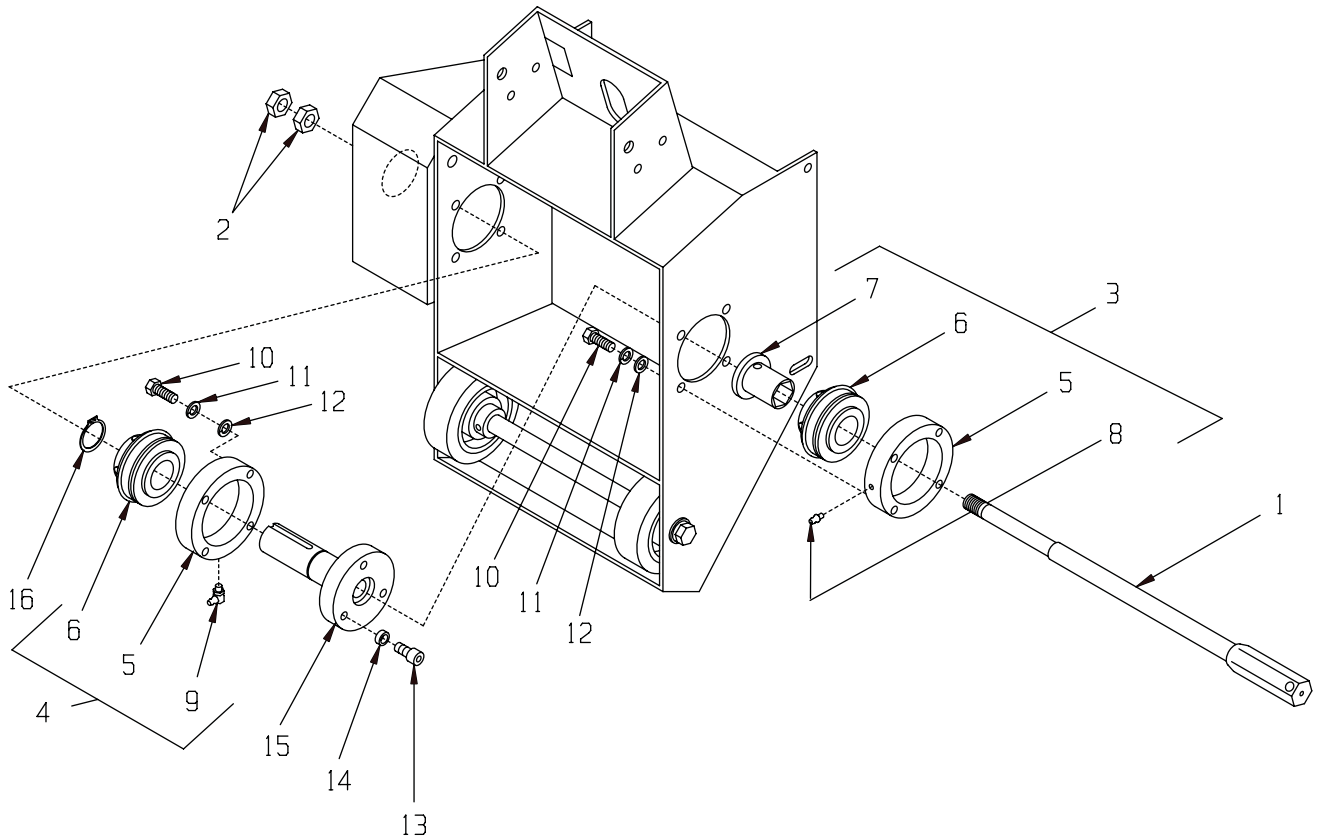

ITEM#	PART#	DESCRIPTION	QTY.
1	65037	DRUM SHAFT 18-3/8" 1	1
2	65039	NUT, JAM 5/8-11 LEFT-HAND THREAD	2
3	65057	BEARING ASSY., COMPLETE, 1" HEX BORE (ITEMS 5 THRU 8)	1
4	65056	BEARING ASSY., COMPLETE, 1-1/4" DIA. (ITEMS 5,6,&9)	1
5	65031	RETAINER, BEARING	2
6	65030	BEARING, BALL 1-1/4" w/ SNAP RING	2
7	65033	BUSHING, BEARING, 1" HEX BORE (PRESS FIT IN BEARING)	1
8	10808	FITTING, GREASE 1/4-28 STRAIGHT	1
9	10961	FITTING, GREASE 1/4-28x90D	1
10	10309	SCREW, CAP 3/8-24x1-1/4	8
11	10811	WASHER, LOCK 3/8	8
12	10025	WASHER, FLAT 3/8	8
13	10878	SCREW, SKT. HD. CAP 3/8-24x1	3
14	10113	SPACER, STEEL 9/16"ODx3/8"IDx7/32"	3
15	65038	DRIVER	1
16	10873	RETAINING RING, EXT. 1-1/4"	1

**ILLUSTRATION 3: ENGINE & BELT DRIVE GROUPING**

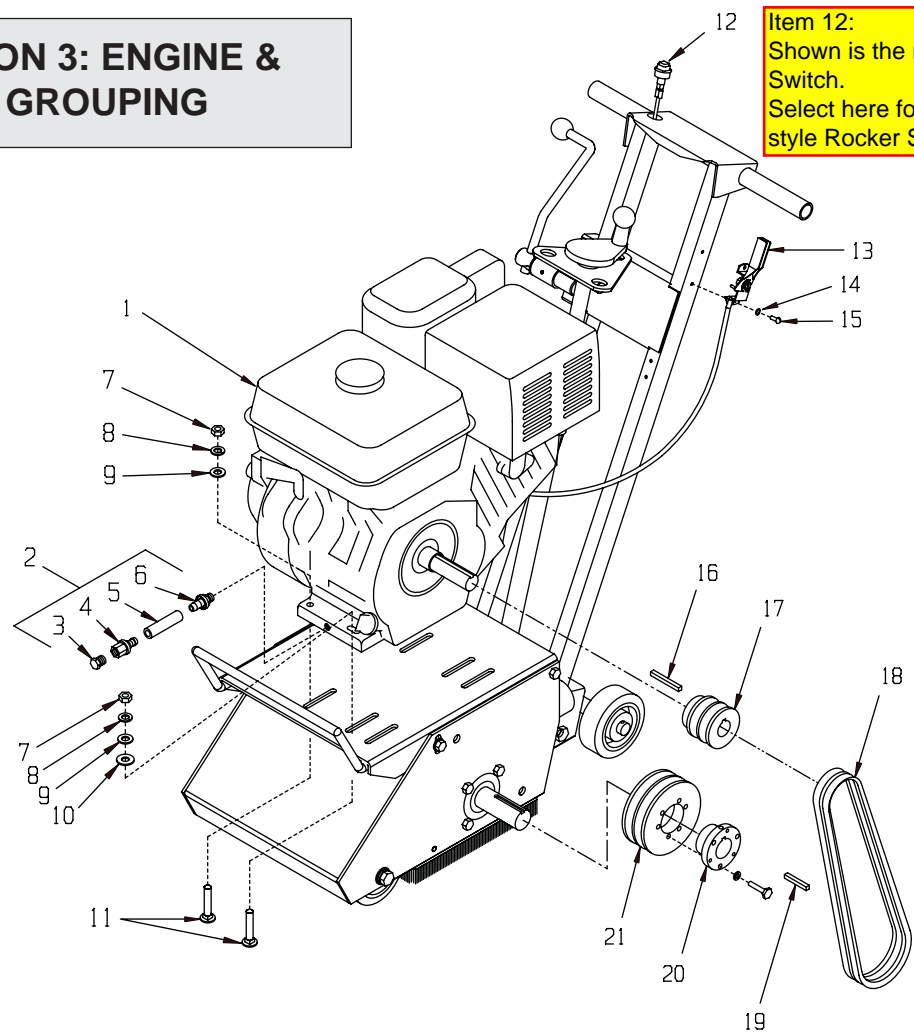

**Item 12:**  
Shown is the round style Push-Button Switch.  
Select here for the new rectangular style Rocker Switch.

ITEM#	PART#	DESCRIPTION	QTY.	ITEM#	PART#	DESCRIPTION	QTY.
1	15027	ENGINE, HONDA 9.0 HP GX270-QXC9 w/ CYCLONE AIR CLEANER	1	12	50010	SWITCH KIT, STOP BUTTON, 7/8" HOLE	1
2	40328	OIL DRAIN KIT FOR 9 HP HONDA (CONTAINS ITEMS 3 THRU 6)	1	13	40388	CABLE, THROTTLE LEVER-TYPE 24"	1
3	10776	PIPE PLUG 1/4 NPT (BRASS)	1	14	10831	WASHER, LOCK, INT. TOOTH #10	2
4	11544	BARB, PUSH-ON 3/8 HOSEx1/4 FPT	1	15	10877	SCREW, CAP STSHW 10-24x1/2	2
5	56116	HOSE, PUSH-ON 3/8"IDx3"L	1	16	10307	KEY 1/4 SQ.x2-1/4	1
6	11542	BARB, PUSH-ON 3/8 HOSEx12mmx1.50 MALE	1	17	10553	SHEAVE, 2.5"ODx2 GR.Ax1" BORE	1
7	10054	NUT 5/16-18	4	18	81007	BELT AX-33	2
8	10801	WASHER, LOCK 5/16	4	19	40317	KEY 1/4 SQ.x1-5/8	1
9	10213	WASHER, FLAT 5/16	4	20	10505	BUSHING, SHEAVE SHx1-1/4" BORE	1
10	10025	WASHER, FLAT 3/8	2	21	65045	SHEAVE 4.05"ODx2 GR.AxSH	1
11	10918	BOLT, CARRIAGE 5/16-18x1-3/4	4				



100 Thomas Johnson Drive, Frederick, MD 21702-4600 USA  
 Phone (301) 663-1600 • 1-800-638-3326  
 Fax (301) 663-1607 • 1-800-447-3326  
 Website: www.edcoinc.com • Email: sales@edcoinc.com

Printed in USA  
 NAA ©2006

# ILLUSTRATION 4: MOTOR & BELT DRIVE GROUPING

REV. STARTING SERIAL # 060210104

REVISED STARTING SERIAL # 060310462  
SELECT HERE FOR NEW ILLUSTRATION

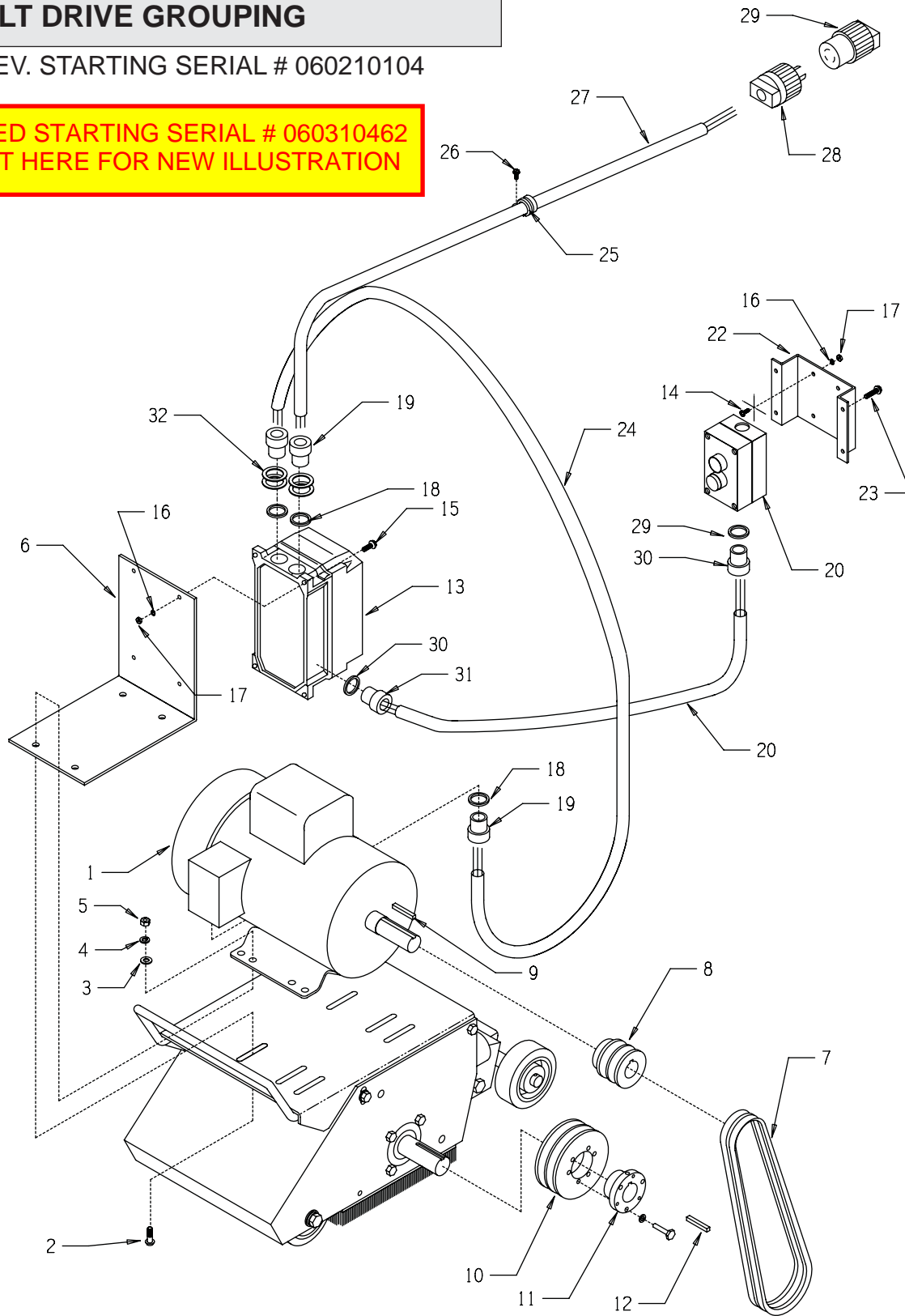



**PARTS LISTING - ILLUSTRATION 4: MOTOR & BELT DRIVE GROUPING**

ITEM#	PART#	DESCRIPTION	QTY.
1		MOTOR (REQUIRES HOLES DRILLED IN BASE FRAME)	1
	81026	BALDOR 5.0HP - 1PH, 60Hz, 3450 RPM	
	81022	BALDOR 5.0HP - 3PH, 60 Hz, 3450 RPM	
	16020	BALDOR 5.0HP - 3PH, 50 Hz, 2850 RPM	
2	10819	BOLT, CARRIAGE 5/16-18 x 1	4
3	10213	WASHER, FLAT 5/16-18	4
4	10801	WASHER, LOCK 5/16-18	4
5	10054	NUT 5/16-18	4
6	65087	STARTER MOUNT	1
7	10239	BELT AP-32	2
8		SHEAVE	1
	10555	2.5 OD x 2 Gr.A x 1-1/8 BORE (60 Hz MOTOR)	
	10526	3.00 OD x 2Gr.A x 1-1/8 BORE (50 Hz MOTOR)	
9	10101	KEY 1/4" SQ. x 1-3/4 (INCL. w/ MOTOR)	1
10	40317	SHEAVE 4.05 OD x 2 Gr.A x SH	1
11	10505	BUSHING, SHEAVE SH x 1-1/4 BORE	1
12	65045	KEY 1/4 SQ. x 1-5/8	1
13		LOVATO STARTER w/ BLUE RESET BUTTON SPECIFY VOLTAGE FOR 50 Hz	1
	16454	1 PHASE 230V 60 Hz	
	16457	3 PHASE 230V 60 Hz	
	16458	3 PHASE 460V 60 Hz	
14	11663	SCREW, MACHINE 8-32 x 1/2	4
15	10362	SCREW, MACHINE 8-32 x 3/4	4
16	10468	WASHER, INT. TOOTH #8	8
17	10462	NUT 8-32	8
18	10740	CONDUIT, LOCK NUT 3/4 NP	3
19	10605	CONNECTOR, STRAIN RELIEF 3/4 NPT x .650-.750	3
20	65101	WIRE HARNESS 16/4 x 48" LOA STARTER TO SWITCH	1
21	16456	REMOTE SWITCH BOX COMPLETE	1
	16456-1	ENCLOSURE, LOVATO 2-BUTTON	1
	16456-2	ENCLOSURE BUTTON, GREEN FLUSH, START	1
	16456-3	ENCLOSURE BUTTON, RED EXTENDED STOP	1
	16456-4	ENCLOSURE CONTACT, START GREEN N.O.	1
	16456-5	ENCLOSURE CONTACT, STOP RED N.C.	1
22	65088	REMOTE SWITCH BRACKET	1
23	10846	SCREW, STHW 1/4-20 x 1/2	4
24		WIRE HARNESS, STARTER TO MOTOR	1
	65102	10/3 x 44" LOA (1 PHASE)	
	65103	10/4 x 44" LOA (3 PHASE)	
25	11565	CLAMP, LOOM 5/8 (SAE SIZE 10)	1
26	10877	SCREW, CAP STSHW 10-24 x 1/2	1
27		WIRE HARNESS, STARTER TO POWER SOURCE	1
	65104	10/3 x 62" LOA ( 1 PHASE)	
	65105	10/4 x 62" LOA (3 PHASE)	
28	40037	PLUG, LOCKING 20A/250V (1 PHASE ONLY)	1
29	40000	CONNECTOR, LOCKING 20A/250V (1 PHASE ONLY)	1
30	10709	CONDUIT LOCK NUT 1/2 NPT	2
31	40066	CONNECTOR, STRAIN RELIEF 1/2 NPT x .350 - .450	2
32	77081	WASHER, FLAT 1-1/2 x 1-1/16 x .06	4



100 Thomas Johnson Drive, Frederick, MD 21702-4600 USA

Phone (301) 663-1600 • 1-800-638-3326

Fax (301) 663-1607 • 1-800-447-3326

Website: www.edcoinc.com • Email: sales@edcoinc.com

Printed in USA

NAA ©2006

**Page 9**

**ILLUSTRATION 5: CUTTER DRUM ASSEMBLY**

STANDARD 8" WIDTH

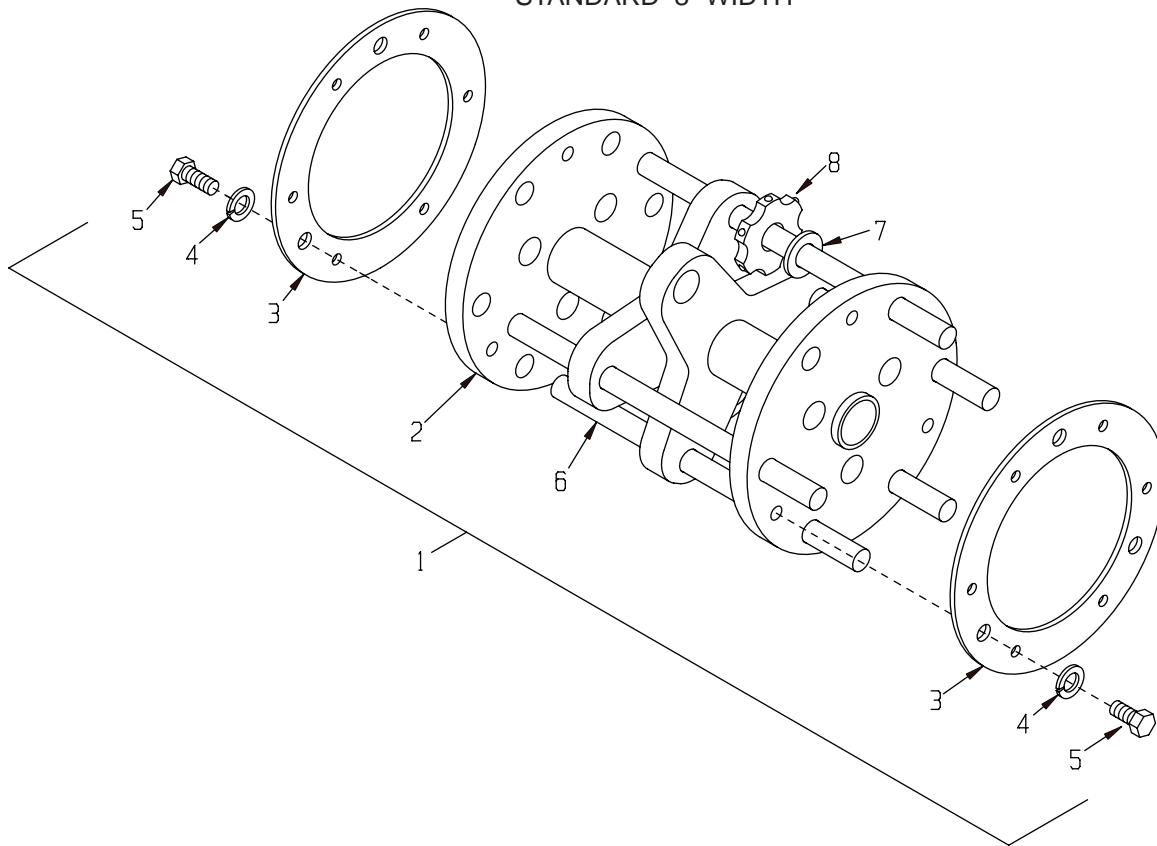

ITEM#	PART#	DESCRIPTION	QTY.
1	65050	DRUM ASSEMBLY, COMPLETE, CPM-8 CUTTER (INCLUDES ITEMS 2 THRU 6)	1
2	65051	DRUM ONLY , CUTTER	1
3	65054	RETAINING PLATE, CUTTER SHAFT	2
4	10801	WASHER, LOCK 5/16	6
5	10053	SCREW, CAP 5/16-18 x 3/4	6
6	20150	CP407 CUTTER SHAFT FOR CPM-8, 8-9/16"L	6
7	12230	CG227 SPACER, 1/2" ID	*
8	*	CUTTER WHEELS	*
	20156	CP206T, 6 POINT TUNGSTEN CARBIDE, (SHOWN) 1-3/4"OD x 5/8"ID x 1/4"THK	
	20256	CP205T, 5 POINT TUNGSTEN CARBIDE , 1-3/4" OD x 5/8" ID x 1/4" THK.	
	20206	CP305, 12 TOOTH FLAT TIP HI CARBON STEEL, 2"OD x 5/8"ID x 3/16"THK	
	12206	JRS501-P, 18 TOOTH POINTED HI CARBON STEEL, 2"OD x 17/32"ID x 3/16"THK	
<p><b>*NOTE:</b> CUTTER WHEELS AND SPACERS ARE NOT INCLUDED WITH DRUM ASSEMBLY. THE NUMBER OF CUTTER WHEELS AND SPACERS VARY WITH TYPE OF SET-UP USED. REFER TO ASSEMBLY INSTRUCTIONS FOR SUGGESTED SET-UPS AND QUANTITIES.</p>			



**ILLUSTRATION 6: DIAMOND GROOVING HEAD ASSEMBLY**

OPTIONAL 7" WIDTH

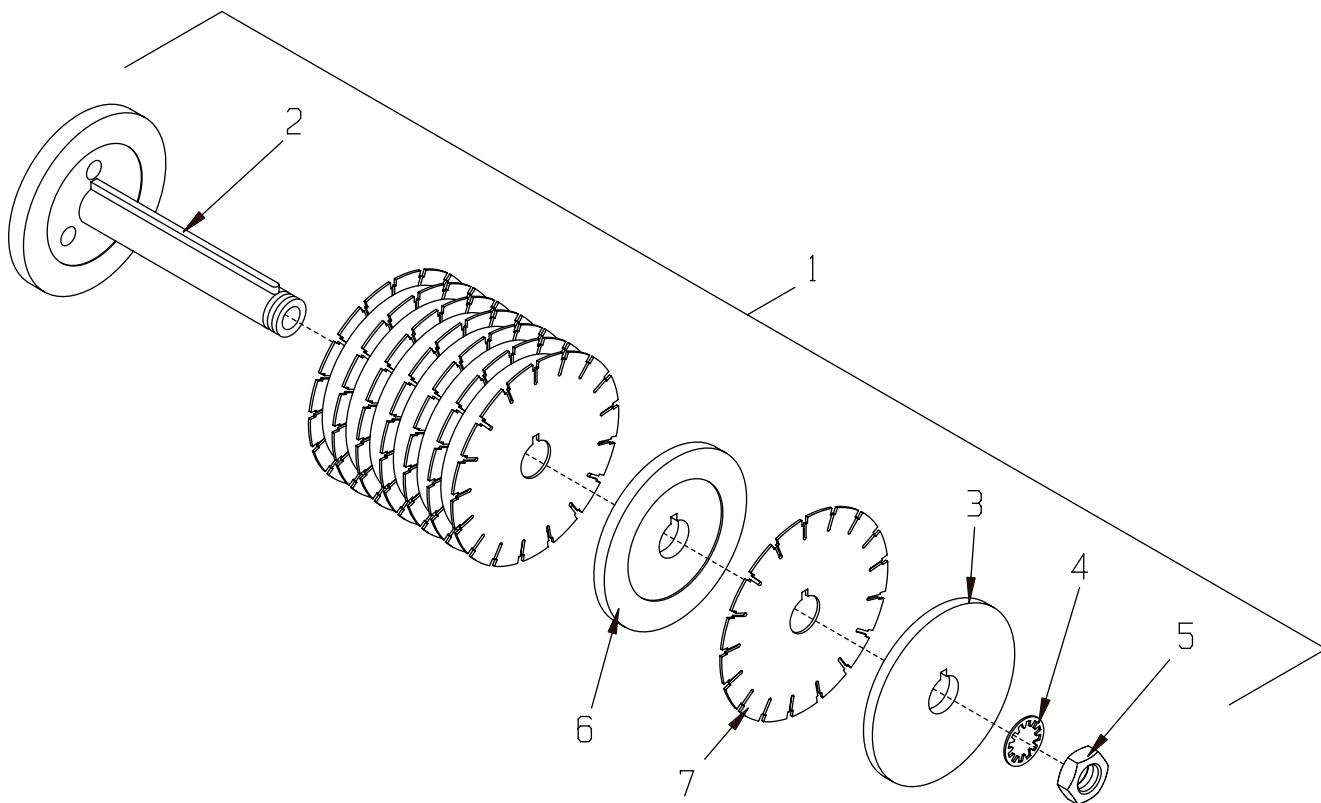

ITEM#	PART#	DESCRIPTION	QTY.
1	65077	DIAMOND GROOVING HEAD ASSEMBLY (INCLUDES ITEMS 2 THRU 5)	
2	65070	ARBOR, DIAMOND GROOVING HEAD	1
3	65071	ARBOR, BLADE RETAINING CAP 6"	1
4	65075	WASHER, LOCK, INT. TOOTH 1-1/4"	1
5	65076	NUT, JAM 1 1/4-12	1
6		SPACER, BLADE	*
	65072	6"O.D.x1-1/4" I.D.x.063" THK.	
	65073	6"O.D.x1-1/4" I.D.x.43" THK. (1/2" SPACING)	
	65074	6"O.D.x1-1/4" I.D.x.93" THK. (1" SPACING)	
	65078	6"O.D.x1-1/4" I.D.x5/8" THK.	
7	39808	DIAMOND BLADE 7x.090x1.25" w/ KEYWAY	*

\*NOTE:  
DIAMOND BLADES AND SPACERS ARE NOT INCLUDED WITH HEAD ASSEMBLY.  
THESE QUANTITIES VARY WITH THE TYPE OF SET-UP USED.



# ILLUSTRATION 7: OPTIONAL EDGER ASSEMBLY

PART NO. 65027

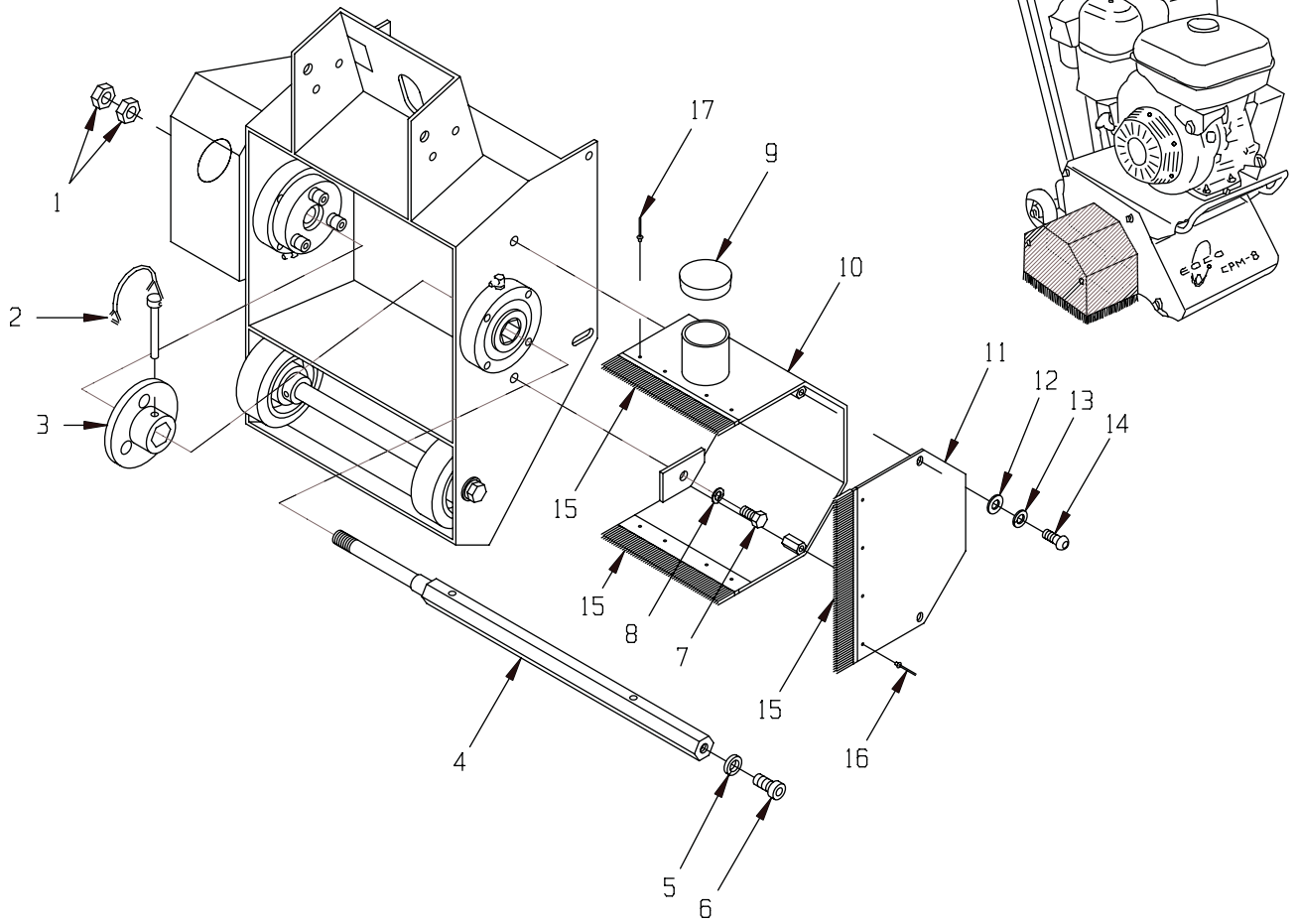

ITEM#	PART#	DESCRIPTION	QTY.
1	65039	NUT, JAM 5/8-11 LEFT-HAND THREAD	2
2	65028	PIN, WIRE LOCK 5/16x2-3/4	1
3	65026	FLANGE, DRIVER	1
4	65025	DRUM SHAFT, EDGER	1
5	10420	WASHER, LOCK 1/2 HEAVY-DUTY	1
6	10490	SCREW, SKT. HD. CAP 1/2-13x1	1
7	10907	SCREW, CAP 3/8-16x3/4	2
8	10811	WASHER, LOCK 3/8	2
9	65021	PLUG, CAP 2" TUBE	1
10	65023	COVER w/ BRUSHES	1
11	65024	COVER SIDE PANEL w/ BRUSH	1
12	10213	WASHER, FLAT 5/16	2
13	10801	WASHER, LOCK 5/16	2
14	10627	SCREW, SKT. BUTTON HEAD 5/16-18x3/4	2
15	65029	BRUSHES, EDGER, (SET OF 3, INCLUDED WITH ITEMS 10 & 11)	1
16	10128	RIVET, BLIND 1/8x.250"Lx.262" HD. DIA.	4
17	10134	RIVET, BLIND 3/16x.450"Lx.375" HD. DIA.	8



**ILLUSTRATION 8: EDGER CUTTER DRUM ASSEMBLY**

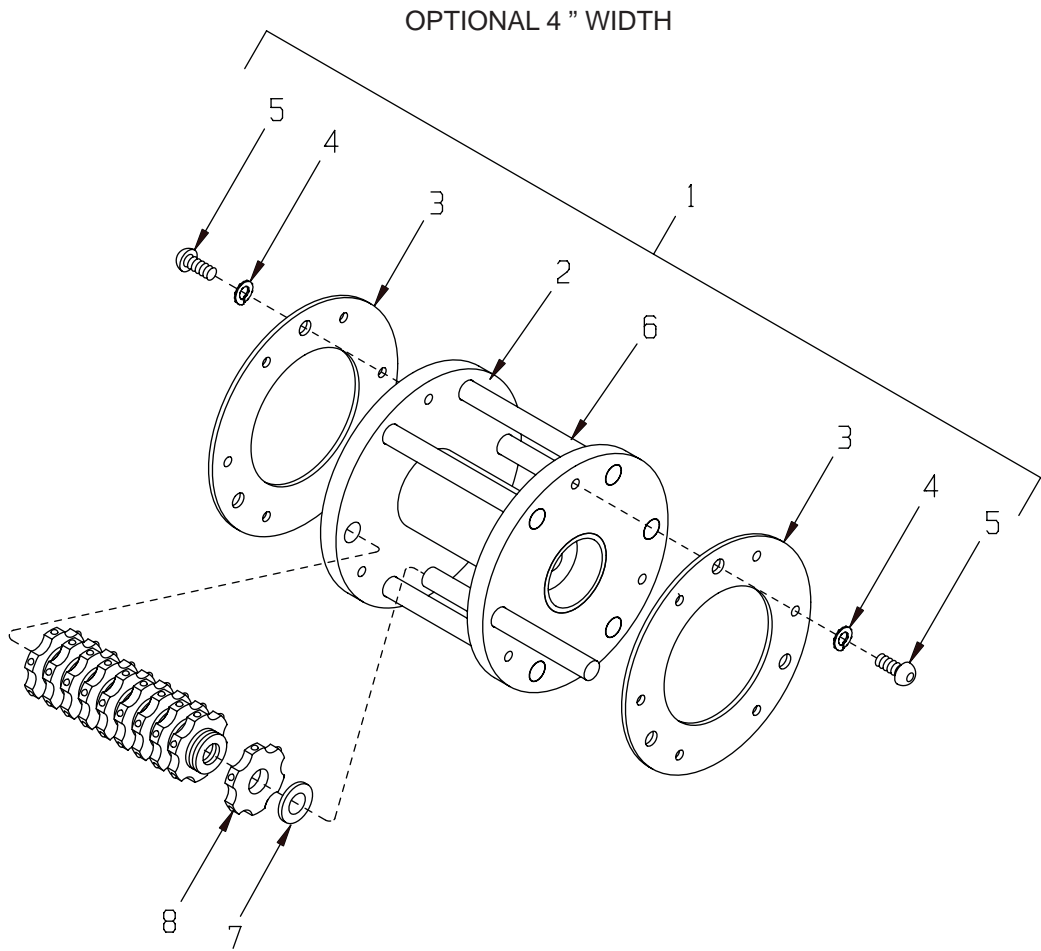

ITEM#	PART#	DESCRIPTION	QTY.
1	C66040	DRUM ASSEMBLY, COMPLETE, CPM-8 CUTTER (INCLUDES ITEMS 2 THRU 6)	1
2	C66041	DRUM ONLY , CUTTER, CPM-4	1
3	65054	RETAINING PLATE, CUTTER SHAFT	2
4	10801	WASHER, LOCK 5/16	6
5	10627	SCREW, SKT. BUTTON HEAD 5/16-18 x 3/4	6
6	C66043	CP410 SHAFT, 1/2 X 5-3/16"L	6
7	12230	CG227 SPACER, 1/2" ID	*
8	*	CUTTER WHEELS	*
	20156	CP206T CUTTER WHEEL, 1-3/4" CARBIDE (SHOWN) 1-3/4" OD x 5/8" ID x 1/4" THK.	
	20256	CP206T, 5 POINT TUNGSTEN CARBIDE, 1-3/4" OD x 5/8" ID x 1/4" THK.	
	20206	CP305 CUTTER WHEEL, FLAT TIP 2" OD x 5/8" ID x 3/16" THK.	
	12206	JRS501-P CUTTER WHEEL, POINTED 2" OD x 17/32" ID x 3/16" THK.	

**\*NOTE:**  
 CUTTER WHEELS AND SPACERS ARE NOT INCLUDED WITH DRUM ASSEMBLY.  
 THE NUMBER OF CUTTER WHEELS AND SPACERS VARY WITH TYPE OF SET-UP USED.  
 REFER TO ASSEMBLY INSTRUCTIONS FOR SUGGESTED SET-UPS AND QUANTITIES.



100 Thomas Johnson Drive, Frederick, MD 21702-4600 USA  
 Phone (301) 663-1600 • 1-800-638-3326  
 Fax (301) 663-1607 • 1-800-447-3326  
 Website: www.edcoinc.com • Email: sales@edcoinc.com

**ILLUSTRATION 9: OPTIONAL SHAFT COVER KIT**

PART NO. 65097K

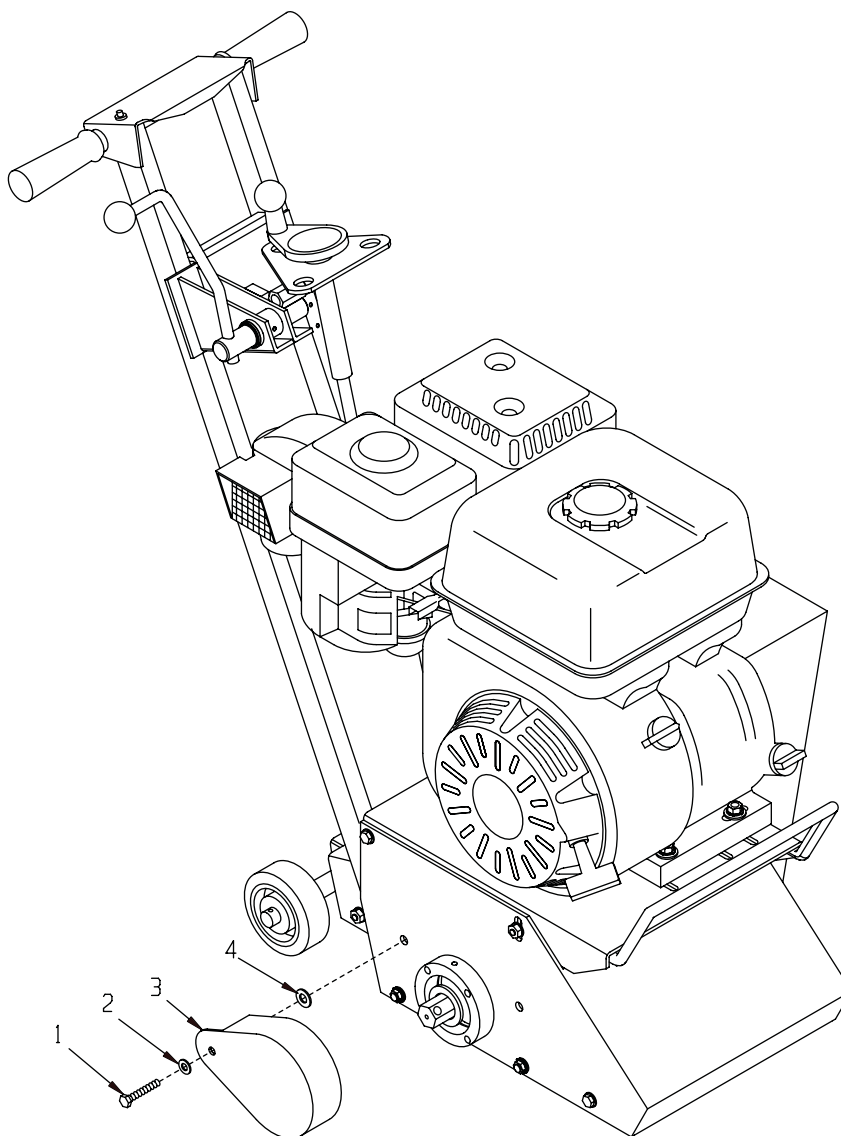

ITEM#	PART#	DESCRIPTION	QTY.
1	10410	BOLT, TAP 3/8-16 x 2-1/2 (FULL THD.)	1
2	10811	WASHER, LOCK 3/8	1
3	65097	COVER, SHAFT	1
4	10025	WASHER, FLAT 3/8	1



## NOTES



100 Thomas Johnson Drive, Frederick, MD 21702-4600 USA  
Phone (301) 663-1600 • 1-800-638-3326  
Fax (301) 663-1607 • 1-800-447-3326  
Website: [www.edcoinc.com](http://www.edcoinc.com) • Email: [sales@edcoinc.com](mailto:sales@edcoinc.com)

Printed in USA  
NAA ©2006

# LIMITED EQUIPMENT WARRANTY

Equipment Development Company, Inc. herein referred to as EDCO warrants that each new unit manufactured by EDCO to be free from defects in material and workmanship in normal use and service for a period of (1) one year (except in the case of the cutter drum assembly on all model concrete asphalt planes, in which case the warranty period shall be 90 days) from date of shipment to the original buyer or equipment rental center owner.

EDCO will, at its option, repair or replace, at the EDCO factory or at a point designated by EDCO any part, which shall appear to the satisfaction of EDCO inspection to have been defective in material or workmanship.

This warranty, does not apply to failure occurring as a result of abuse, misuse, negligent repairs, corrosion, erosion, normal wear and tear, alterations or modifications made to the product without express written consent of EDCO: or failure to follow the recommended operating practices and maintenance procedures as provided in the products operating and maintenance manuals.

This warranty does not obligate EDCO to bear any transportation charges in connection with the replacement or repair of defective parts. This warranty does not obligate EDCO to bear any expense for travel time or of personnel in connection with any service calls.

Accessories or equipment furnished and installed on the product by EDCO but manufactured by others, including but not limited to engines, motors, electrical equipment, transmissions, etc., shall carry the accessory manufacturers' own warranty.

THIS WARRANTY IS IN LIEU OF ALL OTHER WARRANTIES, EXPRESSED OR IMPLIED, OR STATUTORY, INCLUDING ANY WARRANTIES OF MERCHANTABILITY OR OF FITNESS FOR A PARTICULAR PURPOSE.

## LIABILITY LIMITATIONS

The remedies of the user set forth under provisions of warranty outlined above are the exclusive and total liability of EDCO with the respect to their sale or the equipment and service furnished hereunder, in connection with the performance or breach thereof, or from the sale, delivery, installation, repair or technical direction covered by or furnished under the sale, whether based on contract, warranty, negligence, indemnity, strict liability, or otherwise shall not exceed the purchase price of the unit of equipment upon which such liability is based.

EDCO will not in any event be liable to the user, any successors in interest or any beneficiary or assignee relating to this sale for any consequential, incidental, indirect, special or punitive damages arising out of this sale or any breach thereof, or any defects on, or failure of, or malfunction of the equipment under this sale based upon loss of use, lost profits or revenue, interest, lost goodwill, work stoppage, impairment of other goods, loss by reason of shutdown or non-operation, increased expenses of operation of the equipment, cost of purchase or replacement power of claims of users or customers of the user for service interruption whether or not such loss or damage is based on contract, warranty, negligence, indemnity, strict liability, or otherwise.

EDCO reserves the right to modify, alter and improve any part or parts without incurring any obligation to replace any part or parts previously sold without such modified, altered or improved part or parts.

No person is authorized to give any other warranty or to assume any additional obligation on EDCO's behalf unless made in writing and signed by an officer of EDCO.

Equipment Development Company, Inc.

**USE ONLY GENUINE EDCO PARTS AND ACCESSORIES**  
For your own safety, the safety of others and the life of your machine





**ILLUSTRATION 4: MOTOR & BELT DRIVE GROUPING**

REVISED STARTING SERIAL # 060310462

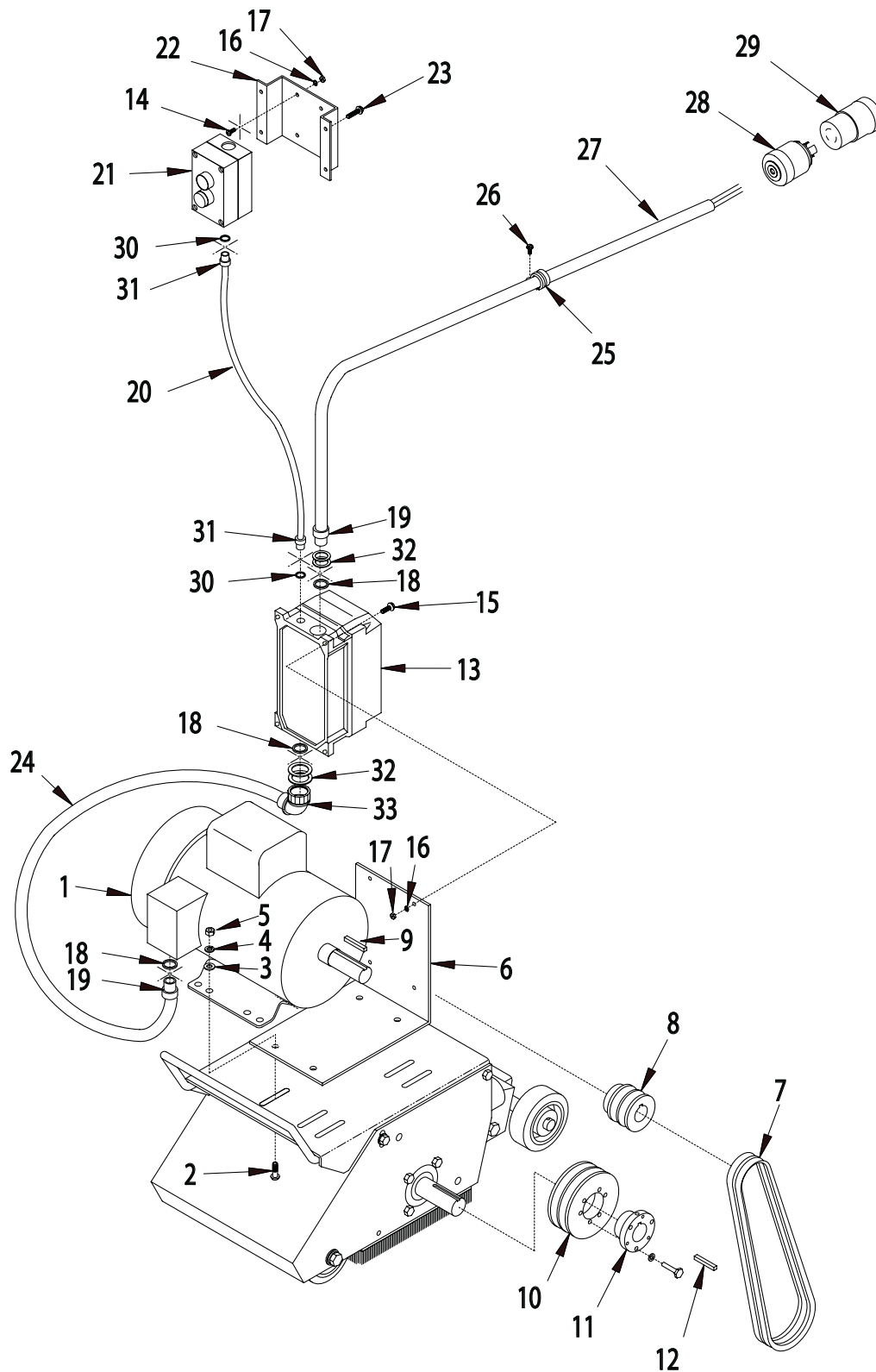

100 Thomas Johnson Drive, Frederick, MD 21702-4600 USA  
 Phone (301) 663-1600 • 1-800-638-3326  
 Fax (301) 663-1607 • 1-800-447-3326  
 Website: [www.edcoinc.com](http://www.edcoinc.com) • Email: [sales@edcoinc.com](mailto:sales@edcoinc.com)

<b>PARTS LISTING - ILLUSTRATION 4: MOTOR &amp; BELT DRIVE GROUPING</b>			
ITEM#	PART#	DESCRIPTION	QTY.
1		MOTOR (REQUIRES HOLES DRILLED IN BASE FRAME)	1
	81026	BALDOR 5.0HP - 1PH, 60Hz, 3450 RPM, 230V	
	81022	BALDOR 5.0HP - 3PH, 60 Hz, 3450 RPM, 230/460V	
	16020	BALDOR 5.0HP - 3PH, 50 Hz, 2850 RPM, 220/380/440V	
2	10819	BOLT, CARRIAGE 5/16-18 x 1	4
3	10213	WASHER, FLAT 5/16-18	4
4	10801	WASHER, LOCK 5/16-18	4
5	10054	NUT 5/16-18	4
6	65087	STARTER MOUNT	1
7	10239	BELT AP-32	2
8		SHEAVE	1
	10555	2.5 OD x 2 Gr.A x 1-1/8 BORE (60 Hz MOTOR)	
	10526	3.00 OD x 2Gr.A x 1-1/8 BORE (50 Hz MOTOR)	
9	10101	KEY 1/4" SQ. x 1-3/4 (INCL. w/ MOTOR)	1
10	65045	SHEAVE 4.05 OD x 2 Gr.A x SH	1
11	10505	BUSHING, SHEAVE SH x 1-1/4 BORE	1
12	40317	KEY 1/4 SQ. x 1-5/8	1
13		LOVATO STARTER w/ BLUE RESET BUTTON	1
		SPECIFY VOLTAGE FOR 50 Hz	
	16454	1 PHASE 230V 60 Hz, 11-M1-BRF-R30-26-23060	
	16457	3 PHASE 230V 60 Hz, 11-M1-BRF-R23-15-23060	
	16458	3 PHASE 460V 60 Hz, 11-M1-BRF-R14-10-46060	
14	11663	SCREW, MACHINE 8-32 x 1/2	4
15	10362	SCREW, MACHINE 8-32 x 3/4	4
16	10461	WASHER, INT. TOOTH #8	8
17	10462	NUT 8-32	8
18	10740	CONDUIT, LOCK NUT 3/4 NP	3
19	10605	STRAIN RELIEF 3/4 NPT x .650-.750	2
20	65106	WIRE HARNESS 16/4 x 36" LOA STARTER TO SWITCH	1
21	16456	REMOTE SWITCH BOX COMPLETE	1
	16456-1	ENCLOSURE, LOVATO 2-BUTTON	1
	16456-2	ENCLOSURE BUTTON, GREEN FLUSH START	1
	16456-3	ENCLOSURE BUTTON, RED EXTENDED STOP	1
	16456-4	ENCLOSURE CONTACT, START GREEN N.O.	1
	16456-5	ENCLOSURE CONTACT, STOP RED N.C.	1
22	65088	REMOTE SWITCH BRACKET	1
23	10846	SCREW, CAP STSHW 1/4-20 X 1/2	4
24		WIRE HARNESS, STARTER TO MOTOR	1
	65107	10/3 x 28" LOA (1 PHASE)	
	65108	10/4 x 28" LOA (3 PHASE)	
25	11565	CLAMP, LOOM 5/8 (SAE SIZE 10)	1
26	10877	SCREW, CAP STSHW 10-24 x 1/2	1
27		WIRE HARNESS, STARTER TO POWER SOURCE	1
	65104	10/3 x 48" LOA ( 1 PHASE)	
	65105	10/4 x 48" LOA (3 PHASE)	
28	40037	PLUG, LOCKING 20A/250V (1 PHASE ONLY)	1
29	40000	CONNECTOR, LOCKING 20A/250V (1 PHASE ONLY)	1
30	10790	CONDUIT LOCK NUT 1/2 NP	2
31	40066	STRAIN RELIEF 1/2 NPT x .350 - .450	2
32	77081	WASHER, FLAT 1-1/2 x 1-1/16 x .06	4
33	10984	CONN., LIQUID TITE 90D X 3/4NPT	1

**NEW STYLE  
ENGINE ON/OFF SWITCH ASSEMBLY**

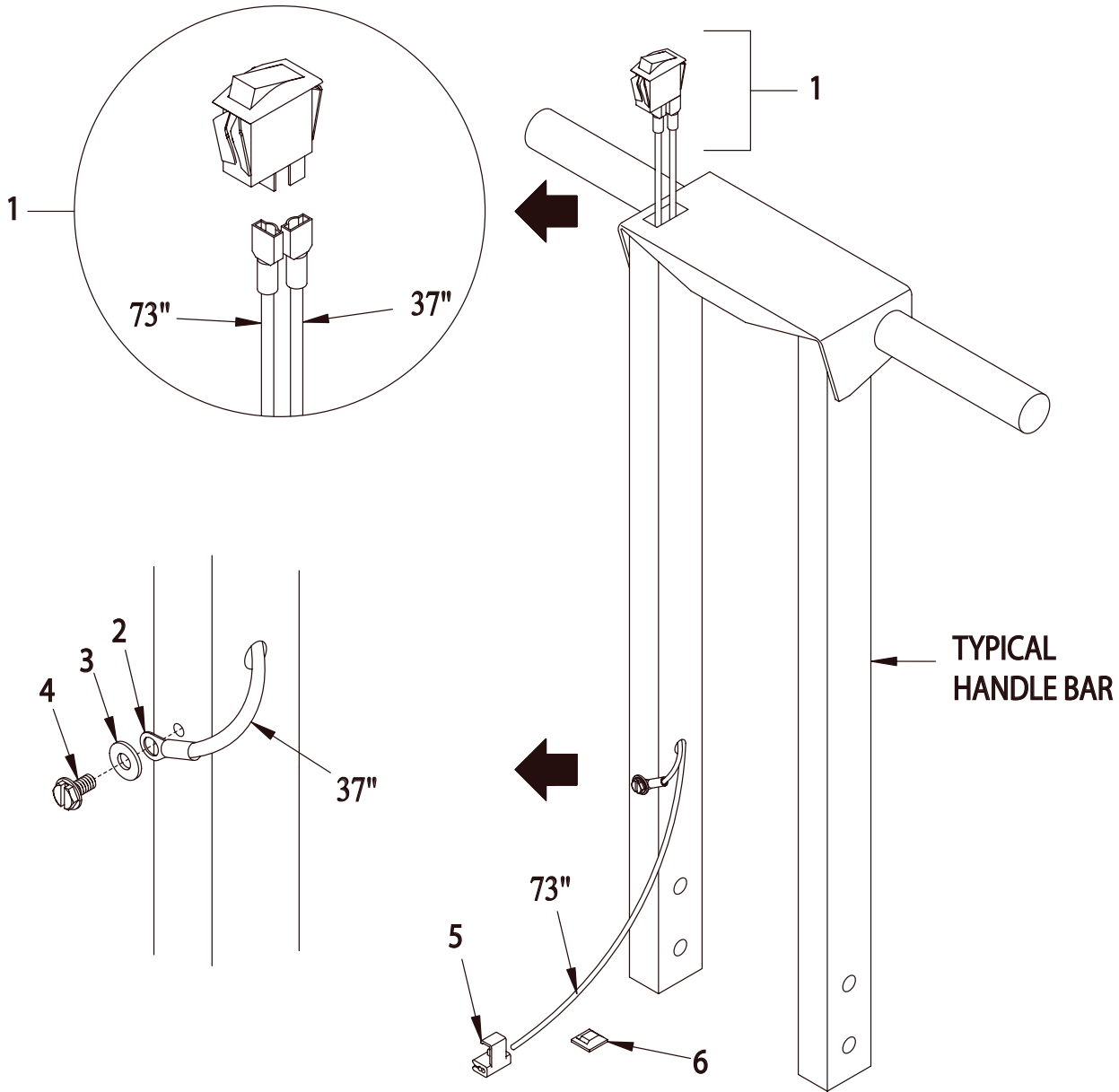

ITEM#	PART#	DESCRIPTION	QTY.
1	15201A	SWITCH SUBASSY., ROCKER ON-OFF (AVAILABLE ONLY AS COMPLETE ASSY.)	1
2	50084	TERM., RING #10 16-14GA. INSULATED (CONNECT TO ITEM 4)	1
3	10831	WASHER, LOCK, INT. TOOTH #10	1
4	10877	SCREW, CAP STSHW 10-24 X 1/2	1
5	10970	CONN., WIRE QUICK-SPLICE 18-14 GA. (SPLICE ITEM 5 WITH ENGINE STOP WIRE)	1
6	36042	CLIP, ADHESIVE BACK CORD 5/8x5/8	AS REQ'D.



100 Thomas Johnson Drive, Frederick, MD 21702-4600 USA  
 Phone (301) 663-1600 • 1-800-638-3326  
 Fax (301) 663-1607 • 1-800-447-3326  
 Website: www.edcoinc.com • Email: sales@edcoinc.com

Printed in USA  
 ©2006