

REVISED STARTING SERIAL # 080810103

PARTS LIST MANUAL

8" TILE STRIPPER



TS8 TILE SHARK

SKU #	MODEL #	POWER OPTION
94400	TS8-.75L	LEESON .75 HP ELECTRIC MOTOR, 60Hz, 1 PHASE, 115/208-230V, 10.8/5.4 F.L.AMPS
94500	TS8-.75L/50H	LEESON .75 HP ELECTRIC MOTOR, 50Hz, 1 PHASE, 110/220V, 11.8/5.9 F.L.AMPS



A Division of Equipment Development Company, Inc.

100 Thomas Johnson Drive, Frederick, MD 21702-4600 USA
 Phone (301) 663-1600 • 1-800-638-3326
 Fax (301) 663-1607 • 1-800-447-3326
 Website: www.edcoinc.com
 Email: sales@edcoinc.com

Printed in USA
 ©2008

READ AND UNDERSTAND THE OPERATORS INSTRUCTION MANUAL THOROUGHLY BEFORE ATTEMPTING TO OPERATE THIS EQUIPMENT. Death or serious injury could occur if this machine is used improperly.



SAFETY MESSAGES



The safety instructions are preceded by a graphic alert message of DANGER, WARNING, or CAUTION.



Indicates an imminent hazard which, if not avoided, will result in death or serious injury.



Indicates an imminent hazard which, if not avoided, can result in death or serious injury.



Indicates hazards which, if not avoided, could result in serious injury and or damage to the equipment.

GASOLINE Powered Equipment



- Do not operate gasoline powered equipment without adequate ventilation. Carbon monoxide is an invisible, odorless gas that can kill.

ELECTRICAL Powered Equipment



- ELECTRICAL HAZARD** - Be sure equipment is properly grounded. Failure to comply could kill or result in serious injury.



The engine exhaust from this product contains chemicals known to the State of California to cause cancer, birth defects or other reproductive harm.

GENERAL INSTRUCTIONS



- You must read and understand the operators instruction manual and all other manuals associated with this machine. For your safety and the safety of others around you, it is extremely important to fully understand how to operate this machine in the way it was intended. Different model machines or older/newer versions of the same model may have different parts and controls that you need to understand. If instructions are not readable or available DO NOT USE this machine and contact the factory for a replacement Manual.
- You must be able to physically handle the bulk weight and power of this machine. If not properly controlled this machine can cause death or serious injury.
- Do not operate this machine in an impaired mental state. You must be able to exercise good judgement and reactions to maintain a safe working environment.
- This is a "one person" machine which means only one operator can be operating the machine at any one time. For the safety of others, maintain a safe operating distance to other personnel. Your work area should be defined and appropriately marked so bystanders and coworkers do not stand or walk near this machine and end up seriously injured by flying debris or exposing them to harmful noise or dust.
- This equipment is for Commercial use. Although this is a "one person" machine your work team should understand how to shut this machine off and quickly get medical help if an accident strikes the operator.
- Keep all guards in place during operation. The guards are to provide protection from inadvertent contact with dangerous moving parts, pinch points, or hot surfaces.
- Wear appropriate Personal Protective Equipment (PPE) including safety glasses, safety boots, work gloves, respiratory protection, hearing protection, and head protection. Do not wear loose clothing that can get tangled in moving parts. Failure to do so could result

in dismemberment or death. **Wear an approved respirator when removing hazardous materials or when grinding/cutting dry materials. Some dust particles such as concrete dust can contain silicate particles which can cause silicosis (a very serious lung disease). Contact NIOSH or OSHA for further details. When wet grinding/cutting, avoid contact with the concrete/asphalt slurry which can cause serious skin irritations.**

- You must maintain this machine per the maintenance schedule in the operator manual. Remember before adjusting, servicing, or fueling this machine, disconnect the source of power to the machine by disconnecting the spark plug (Gas models), or by unplugging the electrical power cord (electric models) or air hose (Pneumatic models) AT THE MACHINE so you can assure yourself it remains unplugged while you are working on it. Do not modify this machine. Use only genuine EDCO parts and accessories. Repairs and service should be performed by approved EDCO dealers or authorized technicians.
- You should look carefully around the area before you begin work so you can identify potential hazards such as deck inserts, pipes, columns, openings, electrical cords or outlets, or any other objects protruding from the slab surface.
- This machine has no brain so you must use your own. There is no substitute for safety. The safety decals on the machine are to serve as a reminder for information you must already know before you begin using this machine. Take a moment to reread the safety decals each time you use the machine. If your machine is missing any decals, contact the factory for a replacement (EDCO 1-800-638-3326).

PARTS LIST MANUAL

MODEL TS8

<u>Section</u>	<u>Page Number</u>
Safety Messages / General Instructions.	2
How To Order Replacement Parts.	3
Illustration 1 : Main Grouping	4,5
Illustration 2 : Handle Grouping	6,7
Illustration 3 : Motor Grouping	8,9
Illustration 4 : 50/60Hz 1-Phase Wiring Diagram	10
Limited Equipment Warranty of Sale.	Back Page

<p>HOW TO ORDER REPLACEMENT PARTS</p> <ul style="list-style-type: none"> ❑ To insure product safety and reliability, always use genuine EDCO replacement parts when making repairs to the equipment. ❑ When calling for parts, specify the MODEL and SERIAL number of the machine, which can be found on the NAME PLATE. Keep that information in the space provided. In addition to this information, give part number, description, and quantity as listed on the parts list to your parts representative. ❑ Please note: Due to improvements and changes in the equipment, the illustrations shown may be different than the actual machine. 	<p style="text-align: center;">FILL IN INFORMATION BELOW</p> <p>Date of Purchase _____</p> <p>Model # _____</p> <p>Serial # _____</p> <p>SKU # _____</p>
---	---

ILLUSTRATION 1: MAIN GROUPING

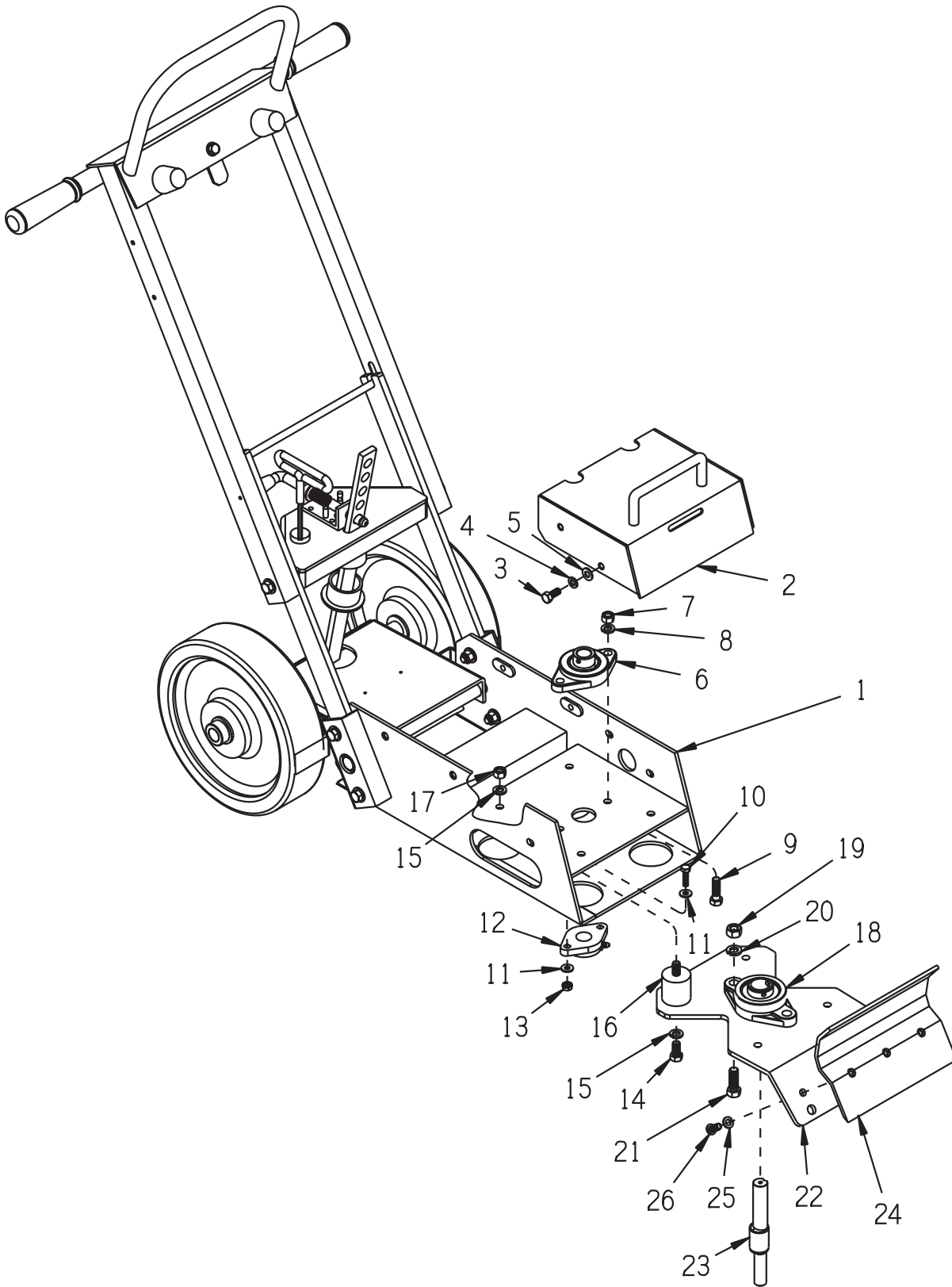

PARTS LISTING - ILLUSTRATION 1: MAIN GROUPING			
ITEM#	PART#	DESCRIPTION	QTY.
1	28101	MAIN FRAME	1
2	28137	HOOD	1
3	10053	SCREW, CAP 5/16-18 X 3/4	4
4	10801	WASHER, LOCK 5/16	4
5	10213	WASHER, FLAT 5/16 SAE	4
6	50049	BEARING, BALL 3/4" 2-HOLE FLANGE	1
7	10014	NUT 3/8-24	2
8	10811	WASHER, LOCK 3/8	2
9	10309	SCREW, CAP 3/8-24 X 1-1/4 PLATED	2
10	10031	SCREW, CAP 1/4-20 X 1	2
11	10602	WASHER, FLAT 1/4 SAE	4
12	80009G	BEARING, BALL 5/8" 2-HOLE (W/ G.F.)	1
13	10861	NUT, KEPS 1/4-20	2
14	10907	SCREW, CAP 3/8-16 X 3/4	4
15	10811	WASHER, LOCK 3/8	8
16	28115	MOUNT, FLEX-BOLT SANDWICH 3/8-16	4
17	10404	NUT 3/8-16	4
18	62022	BEARING, BALL 1" 2-HOLE FLANGE	1
19	10481	NUT 7/16-20	2
20	10450	WASHER, LOCK 7/16	2
21	10003	SCREW, CAP 7/16-20 X 1-1/4	2
22	28145	STRIKER PLATE	1
23	28116	CAM SHAFT, STRIKER PLATE	1
24	28146	RETAINER, SCRAPER BLADE	1
25	10801	WASHER, LOCK 5/16	3
26	10627	SCREW, SKT. BUTTON HD. 5/16-18 X3/4	3



A Division of Equipment Development Company, Inc.

100 Thomas Johnson Drive, Frederick, MD 21702-4600 USA
 Phone (301) 663-1600 • 1-800-638-3326
 Fax (301) 663-1607 • 1-800-447-3326
 Website: www.edcoinc.com
 Email: sales@edcoinc.com

Printed in USA

©2008

Page 5

ILLUSTRATION 2: HANDLE GROUPING

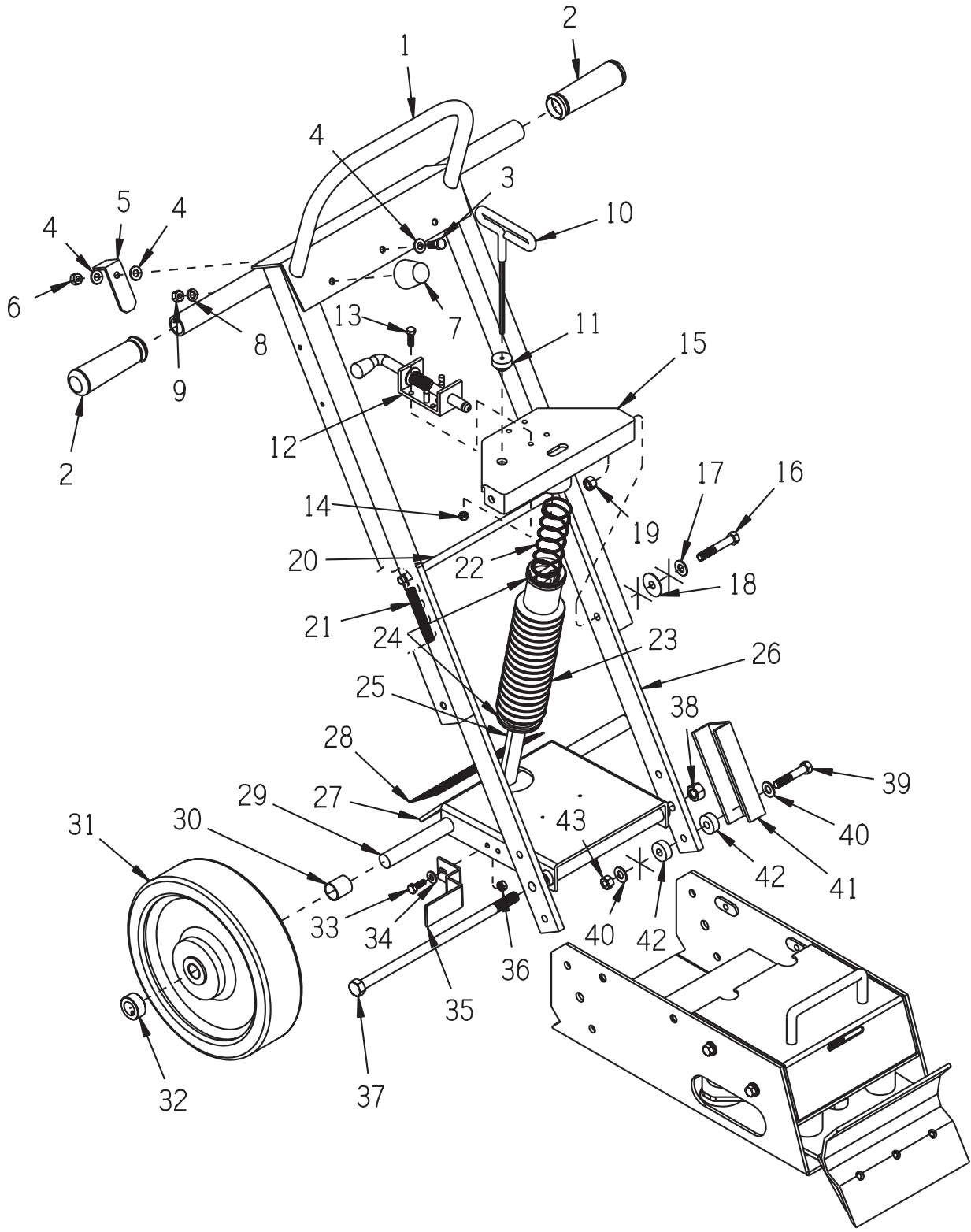

PARTS LISTING - ILLUSTRATION 2: HANDLE GROUPING

ITEM#	PART#	DESCRIPTION	QTY.
1	28109	HANDLE BAR	1
2	10608	GRIP, HAND 1" MODEL AT	2
3	10053	SCREW, CAP 5/16-18 X 3/4	1
4	10213	WASHER, FLAT 5/16 SAE (SHIM LATCH AS NEEDED)	3
5	28125	LATCH, HANDLE HOLD DOWN	1
6	10807	NUT, LOCK 5/16-18	1
7	10931	MOUNT, TAPERED RUBBER 5/16-18	2
8	10801	WASHER, LOCK 5/16	2
9	10807	NUT, LOCK 5/16-18	2
10	28132	WRENCH, HEX KEY 3/16, T-HANDLE	1
11	28122	RUBBER PLUG, HEX KEY WRENCH	1
12	72304	LATCH, SPRING 1/2" SNAP LOCK	1
13	11634	SCREW, CAP M6 X 1.0P X 20MM	4
14	28026	NUT, HEX NYLON LOCK M6 X 1MM	4
15	28147	LATCH SUPPORT WELDMENT	1
16	10336	SCREW, CAP 3/8-24 X 2-1/4	2
17	10025	WASHER, FLAT 3/8 SAE	2
18	28133	WASHER, FLAT 13/32 X 1-1/4 X .047	2
19	10004	NUT, LOCK 3/8-24	2
20	28118	ROD, HANDLE SPRING	1
21	3636	SPRING, EXT. 6"L	2
22	28107	SPRING, COMP. 1.468"OD X 11"FL	1
23	24761	BELLOWS 1-3/4"ID X 10-1/4"LG	1
24	10982	TIE, CABLE, BLACK NYLON 11-1/4"	2
25	28106	ADJUSTMENT BAR, ANGLE	1
26	28117	LEG, HANDLE BAR LOWER	2
27	28103	FORK	1
28	28134	TREAD, ABRASIVE 2-1/2 X 7-1/2	1
29	28104	AXLE SHAFT 3/4"DIA. X 17	1
30	28105	SPACER, WHEEL	2
31	28129	WHEEL, PHENOLIC 10 X 2-1/2 X 3/4BRG	2
32	10428	COLLAR, LOCKING 3/4"ID	2
33	10018	SCREW, CAP 1/4-20 X 3/4	4
34	10602	WASHER, FLAT 1/4 SAE	4
35	28126	WIPER, WHEEL	2
36	10861	NUT, KEPS 1/4-20	4
37	10355	SCREW, CAP 1/2-13 X 11	1
38	10407	NUT, LOCK 1/2-13	1
39	10030	SCREW, CAP 3/8-24 X 2	4
40	10025	WASHER, FLAT 3/8 SAE	8
41	28110	MOUNTING BRKT., HANDLE BAR	2
42	40329	BUSHING, RUBBER 1"OD X 3/8"ID X 3/8	8
43	10004	NUT, LOCK 3/8-24	4



A Division of Equipment Development Company, Inc.

100 Thomas Johnson Drive, Frederick, MD 21702-4600 USA

Phone (301) 663-1600 • 1-800-638-3326

Fax (301) 663-1607 • 1-800-447-3326

Website: www.edcoinc.com

Email: sales@edcoinc.com

Printed in USA

©2008

Page 7

ILLUSTRATION 3: MOTOR GROUPING

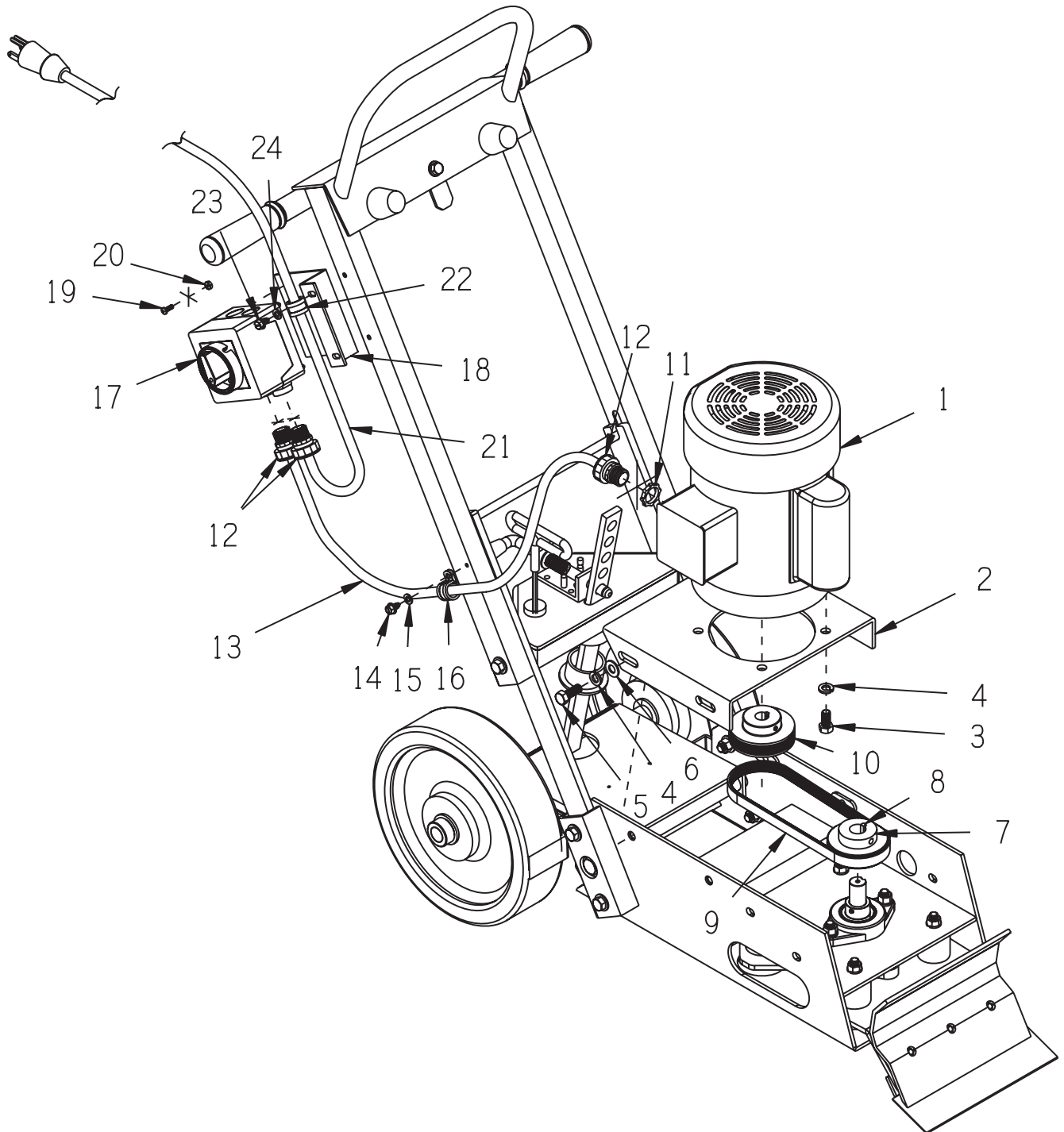

PARTS LISTING - ILLUSTRATION 3: MOTOR GROUPING			
ITEM#	PART#	DESCRIPTION	QTY.
1		MOTOR, LEESON (INCLUDES KEY)	1
	16045	.75HP 60HZ, 1 PHASE, 115/208-230 VOLT, 1725RPM	
		<u>REPLACEMENT PARTS:</u>	
	16182	CAPACITOR, START, LEESON 003024.48 (600MFD 115V)	1
	16153	RESET BUTTON, LEESON 300002.02 (CEJ53CA)	1
	16051	.75HP 50HZ, 1 PHASE, 110/220 VOLT, 1425RPM	
		<u>REPLACEMENT PARTS:</u>	
	16516	CAPACITOR, START, LEESON 003024.16 (440MFD 125V)	1
	16517	RESET BUTTON, LEESON 300031.02 (CED2715)	1
2	28111	MOUNT, MOTOR	1
3	10907	SCREW, CAP 3/8-16 X 3/4	4
4	10811	WASHER, LOCK 3/8	8
5	10055	SCREW, CAP 3/8-16 X 1	4
6	10025	WASHER, FLAT 3/8 SAE	4
7	28130	SHEAVE 2.80"OD X 6GR..J X 3/4"BORE	1
8	10016	KEY 3/16SQ X 1-1/2	1
9	28113	BELT 220J-6 V RIBBED	1
10	28131	SHEAVE 3.0"OD X 6GR.J X 5/8"BORE	1
11	10790	CONDUIT LOCK NUT 1/2 NP	1
12	41130	STRAIN RELIEF 1/2NPT X .550-.650"	3
13	77045	WIRE HARNESS 12/3 X 42"LOA	1
14	10846	SCREW, CAP STSHW 1/4-20 X 1/2	1
15	10038	WASHER, LOCK 1/4	1
16	11565	CLAMP, LOOM, 5/8" (SAE SIZE 10)	1
17	77043	SWITCH, ROTARY CAM ON/OFF, LOVATO	1
18	77042	BRACKET, LOVATO ROTARY CAM SWITCH	1
19	11663	SCREW, MACHINE 8-32 X 1/2	4
20	10462	NUT, KEPS 8-32	4
21	86422	CORD W/ PLUG, 25FT. POWER	1
22	11690	CLAMP, LOOM, 3/8"	1
23	10846	SCREW, CAP STSHW 1/4-20 X 1/2	2
24	10038	WASHER, LOCK 1/4	2



A Division of Equipment Development Company, Inc.

100 Thomas Johnson Drive, Frederick, MD 21702-4600 USA
 Phone (301) 663-1600 • 1-800-638-3326
 Fax (301) 663-1607 • 1-800-447-3326
 Website: www.edcoinc.com
 Email: sales@edcoinc.com

Printed in USA

©2008

Page 9

ILLUSTRATION 4: 50/60Hz 1Ø WIRING DIAGRAM

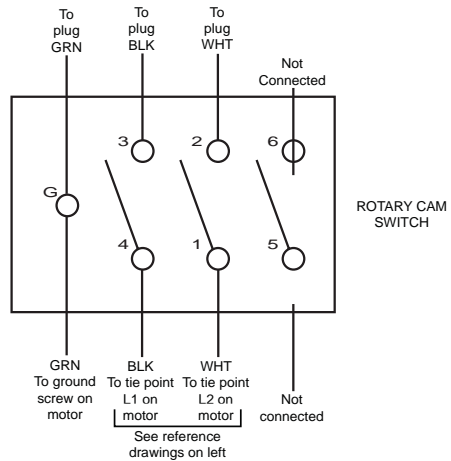
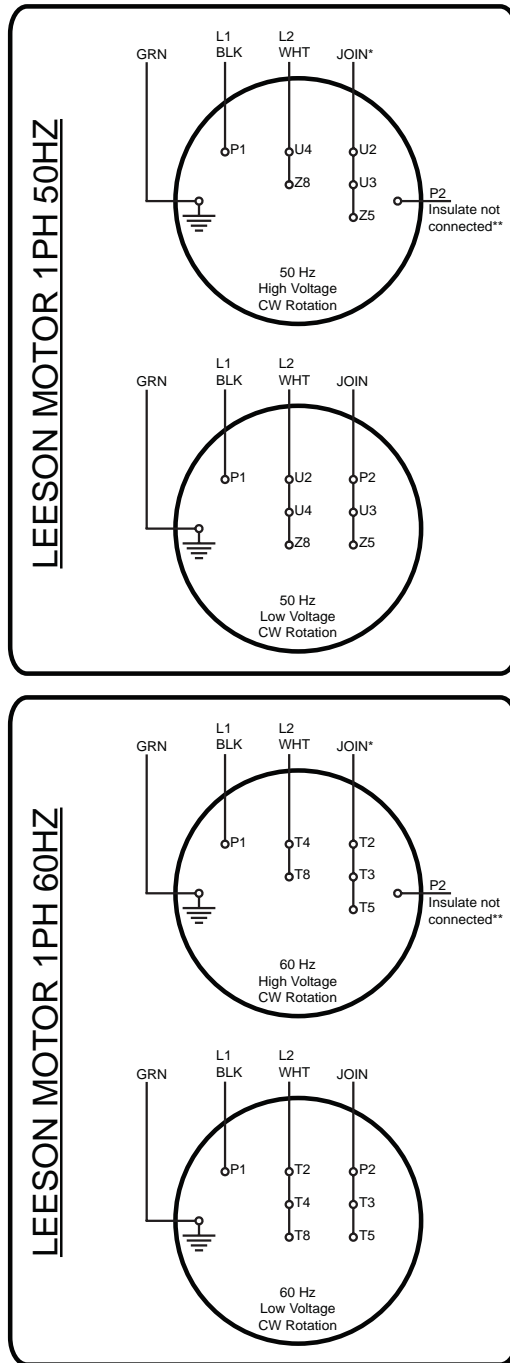

NOTES:

- * Twist these wires together and use a wire nut to secure connection.
- ** This wire is not used, insulate with electrical tape.

WIRING SCHEMES

TS8-50/60_1-PhaseWD.1



A Division of Equipment Development Company, Inc.

100 Thomas Johnson Drive, Frederick, MD 21702-4600 USA
Phone (301) 663-1600 • 1-800-638-3326
Fax (301) 663-1607 • 1-800-447-3326
Website: www.edcoinc.com
Email: sales@edcoinc.com

Printed in USA

©2008

LIMITED EQUIPMENT WARRANTY OF SALE – TERMS & CONDITIONS

Equipment Development Company, Inc. herein referred to as EDCO (Seller) warrants that each new unit manufactured by EDCO to be free from defects in material and workmanship in normal use and service for a period of (1) one year (except for the cutter drum assembly on all model concrete/asphalt planes, in which case the warranty period shall be 90 days) from date of shipment to the original retail or equipment rental center owner.

Accessories or equipment furnished and installed on the product by EDCO but manufactured by others, including, but not limited to engines, motors, electrical components, transmissions etc., shall carry the accessory manufacturers own warranty.

EDCO will, at its option, repair or replace, at the EDCO factory or at a point designated by EDCO, any part which shall appear to the satisfaction of EDCO inspection to have been defective in material or workmanship.

EDCO reserves the right to modify, alter and improve any part or parts without incurring any obligation to replace any part or parts previously sold without such modified, altered or improved part or parts.

This warranty is in lieu of and excludes all other warranties, expressed, implied, statutory, or otherwise created under applicable law including, but not limited to the warranty of merchantability and the warranty of fitness for a particular purpose in no event shall seller or the manufacturer of the product be liable for special, incidental, or consequential damages, including loss of profits, whether or not caused by or resulting from the negligence of seller and/or the manufacturer of the product unless specifically provided herein. In addition, this warranty shall not apply to any products or portions thereof of which have been subjected to abuse, misuse, improper installation, maintenance, or operation, electrical failure or abnormal conditions and to products which have been tampered with, altered, modified, repaired, reworked by anyone not approved by seller or used in any manner inconsistent with the provisions of the above or any instructions or specifications provided with or for the product

FORCE MAJEURE

Seller's obligation hereunder are subject to, and Seller shall not be held responsible for, any delay or failure to make delivery of all or any part of the Product due to labor difficulties, fires, casualties, accidents, acts of the elements, acts of God, transportation difficulties, delays by a common carrier, inability to obtain Product, materials or components or qualified labor sufficient to timely perform part of or all of the obligations contained in these terms and conditions, governmental regulations or actions, strikes, damage to or destruction in whole or part of manufacturing plant, riots, terrorist attacks or incidents, civil commotions, warlike conditions, flood, tidal waves, typhoon, hurricane, earthquake, lightning, explosion or any other causes, contingencies or circumstances within or without the United States not subject to the Seller's control which prevent or hinder the manufacture or delivery of the Products or make the fulfillment of these terms and conditions impracticable. In the event of the occurrence of any of the foregoing, at the option of Seller, Seller shall be excused from the performance under these Terms and Conditions, or the performance of the Seller shall be correspondingly extended.

This document sets forth the terms and conditions pursuant to which the purchaser ("Purchaser") will purchase and Equipment Development Co.Inc. ("Seller") will sell the products, accessories, attachments (collectively the Products") ordered by the Purchaser. These terms and conditions shall govern and apply to the sale of Seller's Products to Purchaser, regardless of any terms and conditions appearing on any purchase order or other forms submitted by Purchaser to Seller, or the inconsistency of any terms therein and herein.

1. PRICE

All prices set forth on any purchase order or other document are F.O.B. Sellers facility or distribution point, as may be determined by Seller (F.O.B.Point). All prices are exclusive of any and all taxes, including, but not limited to, excise, sales, use, property or transportation taxes related to the sale or use of the Products, now or hereafter imposed, together with all penalties and expenses. Purchaser shall be responsible for collecting and/or paying any and all such taxes, whether or not they are stated in any invoice for the Products. Unless otherwise specified herein, all prices are exclusive of inland transportation, freight, insurance and other costs and expenses relating to the shipment of the Products from the F.O.B. point to Purchaser's facility. Any prepayment by Seller of freight insurance and other costs shall be for the account of Purchaser and shall be repaid to Seller.

2. PAYMENT TERMS

Payment terms are as follows. 2% 10 days (to approved and qualified accounts). Net 30 days. This is a cash discount for invoices paid within 10 days after the invoice date, regardless of date of receipt of shipment. This is not a trade discount and will not be granted to accounts that do not adhere to stated terms.

*All past due accounts are subject to a late payment fee of 1.5% per month or a maximum allowed by law if different, along with the expenses incidental to collection including reasonable attorney's fees and costs.

*Seller reserves the right to hold shipments against past due accounts.

*Seller reserves the right to alter payment terms.

3. FREIGHT TERMS

All shipments will be made F.O.B. shipping point as designated in these Terms and Conditions, and title shall pass at the F.O.B. point. Delivery to the initial common carrier shall constitute delivery to the Purchaser. Any claims for loss or damage during shipment are to be filed with carrier by the Purchaser. Seller will not assume responsibility for the performance of the carrier.

Back orders will be shipped in the most practical fashion with charges consistent with our freight policy established with the original order. UPS, FED EX, MAIL or shipments by other couriers are subject to the same terms and conditions as outlined in paragraph #3"Freight Terms".

4. DELIVERY, DAMAGES, SHORTAGES

Seller shall use reasonable efforts to attempt to cause the Products to be delivered as provided for in these Terms & Conditions. Delivery to the initial common carrier shall constitute the delivery to the Purchaser. Sellers responsibility, in so far as transportation risks are concerned ceases upon the delivery of the Products in good condition to such carrier at the F.O.B. point and all the Products shall be shipped at the Purchaser's risk. Seller shall not be responsible or liable for any loss of income and/or profits, or incidental, special, consequential damages resulting from Seller's delayed performance in shipment and delivery.

5. RETURN OF DEFECTIVE PRODUCTS

Defective or failed material shall be held at the Purchaser's premises until authorization has been granted by Seller to return or dispose of Products. Products that are to be returned for final inspection must be returned Freight Prepaid in the most economical way. Credit will be issued for material found to be defective upon Seller's inspection based on prices at time of purchase.

6. PRODUCTS ORDERED IN ERROR

Products may be returned, provided that claim is made and Seller is notified within 7 days of receipt of Products, and the Products are in original buyer's possession not more than 30 days prior to return, subject to Seller's approval. If Products are accepted for return, they must be Freight Prepaid and buyer will be charged a minimum of 15% rehandling charge, plus a charge back for outbound freight charges if the original order was shipped prepaid. Returns are not accepted for any Products that are specifically manufactured to meet the buyer's requirement of either specifications or quantity.

AGREEMENTS

These Terms and Conditions constitute the entire agreement between Seller and Purchaser as it relates to terms and conditions of sale, and supersedes any and all prior oral or written agreements, correspondence, quotations or understandings heretofore in force between the parties relating to the subject matter hereof. There are no agreements between Seller and Purchaser with respect to the Product herein except those specifically set forth in and made part of these terms and conditions. Any additional terms, conditions and/or prices are rejected by Seller.

These terms and conditions may be modified, cancelled or rescinded only by a written agreement of both parties executed by their duly authorized agents.

USE ONLY GENUINE EDCO PARTS & ACCESSORIES
For your own safety, the safety of others and the life of your machine.
Equipment Development Company, Inc.

