

Revised Starting Serial # 1011

PARTS LIST MANUAL

Tile Shark™ 8" Floor Stripper



Model TS-8
Part No. 94400



100 Thomas Johnson Drive, Frederick, MD 21702-4600 USA
Phone (301) 663-1600 • 1-800-638-3326
Fax (301) 663-1607 • 1-800-447-3326
Website: www.edcoinc.com • Email: sales@edcoinc.com

Printed in USA
©2005

READ AND UNDERSTAND THE OPERATORS INSTRUCTION MANUAL THOROUGHLY BEFORE ATTEMPTING TO OPERATE THIS EQUIPMENT. Death or serious injury could occur if this machine is used improperly.



SAFETY MESSAGES



The safety instructions are preceded by a graphic alert message of DANGER, WARNING, or CAUTION.



Indicates an imminent hazard which, if not avoided, will result in death or serious injury.



Indicates an imminent hazard which, if not avoided, can result in death or serious injury.



Indicates hazards which, if not avoided, could result in serious injury and or damage to the equipment.

GASOLINE

Powered Equipment



- Do not operate gasoline powered equipment without adequate ventilation. Carbon monoxide is an invisible, odorless gas that can kill.

ELECTRICAL

Powered Equipment



- ELECTRICAL HAZARD** - Be sure equipment is properly grounded. Failure to comply could kill or result in serious injury.



The engine exhaust from this product contains chemicals known to the State of California to cause cancer, birth defects or other reproductive harm.

GENERAL INSTRUCTIONS



- You must read and understand the operators instruction manual and all other manuals associated with this machine. For your safety and the safety of others around you, it is extremely important to fully understand how to operate this machine in the way it was intended. Different model machines or older/newer versions of the same model may have different parts and controls that you need to understand. If instructions are not readable or available DO NOT USE this machine and contact the factory for a replacement Manual.
- You must be able to physically handle the bulk weight and power of this machine. If not properly controlled this machine can cause death or serious injury.
- Do not operate this machine in an impaired mental state. You must be able to exercise good judgement and reactions to maintain a safe working environment.
- This is a "one person" machine which means only one operator can be operating the machine at any one time. For the safety of others, maintain a safe operating distance to other personnel. Your work area should be defined and appropriately marked so bystanders and coworkers do not stand or walk near this machine and end up seriously injured by flying debris or exposing them to harmful noise or dust.
- This equipment is for Commercial use. Although this is a "one person" machine your work team should understand how to shut this machine off and quickly get medical help if an accident strikes the operator.
- Keep all guards in place during operation. The guards are to provide protection from inadvertent contact with dangerous moving parts, pinch points, or hot surfaces.
- Wear appropriate Personal Protective Equipment (PPE) including safety glasses, safety boots, work gloves, respiratory protection, hearing protection, and head protection. Do not wear loose clothing that can get tangled in moving parts. Failure to do so could result in dismemberment or death. **Wear an approved respirator when removing hazardous materials or when grinding/cutting dry materials. Some dust particles such as concrete dust can contain silicate particles which can cause silicosis (a very serious lung disease). Contact NIOSH or OSHA for further details. When wet grinding/cutting, avoid contact with the concrete/asphalt slurry which can cause serious skin irritations.**
- You must maintain this machine per the maintenance schedule in the operator manual. Remember before adjusting, servicing, or fueling this machine, disconnect the source of power to the machine by disconnecting the spark plug (Gas models), or by unplugging the electrical power cord (electric models) or air hose (Pneumatic models) AT THE MACHINE so you can assure yourself it remains unplugged while you are working on it. Do not modify this machine. Use only genuine EDCO parts and accessories. Repairs and service should be performed by approved EDCO dealers or authorized technicians.
- You should look carefully around the area before you begin work so you can identify potential hazards such as deck inserts, pipes, columns, openings, electrical cords or outlets, or any other objects protruding from the slab surface.
- This machine has no brain so you must use your own. There is no substitute for safety. The safety decals on the machine are to serve as a reminder for information you must already know before you begin using this machine. Take a moment to reread the safety decals each time you use the machine. If your machine is missing any decals, contact the factory for a replacement (EDCO 1-800-638-3326).

PARTS LIST MANUAL

MODEL TS-8 TILE SHARK™

Section	Page Number
Safety Messages and General Instructions	2
How To Order Replacement Parts	3
Illustration 1: Main Frame Grouping	4
Parts Listing - Illustration 1: Main Frame Grouping	5
Illustration 2: Motor Grouping	6
Parts Listing - Illustration 2: Motor Grouping	7
Limited Equipment Warranty	back cover

HOW TO ORDER REPLACEMENT PARTS

To insure product safety and reliability, always use genuine EDCO replacement parts when making repairs to the equipment.

When calling for parts, specify the MODEL and SERIAL NUMBER of the machine which can be found on the NAME PLATE. Keep that information in the space provided. In addition to this information, give part number, description and quantity as listed on the parts list to your parts representative.

Please note: Due to improvements and changes in the equipment, the illustrations shown may be different than the actual machine.

FILL IN INFORMATION BELOW

Date of Purchase _____

Name of Machine _____

Model # _____

Serial # _____

Belt Size(s) _____

Toll Free: 1-800-638-3326

FAX: 1-800-447-3326

email: sales@edcoinc.com

www.edcoinc.com



100 Thomas Johnson Drive, Frederick, MD 21702-4600 USA

Phone (301) 663-1600 • 1-800-638-3326

Fax (301) 663-1607 • 1-800-447-3326

Website: www.edcoinc.com • Email: sales@edcoinc.com

Printed in USA

©2005

Page 3

ILLUSTRATION 1: MAIN FRAME GROUPING

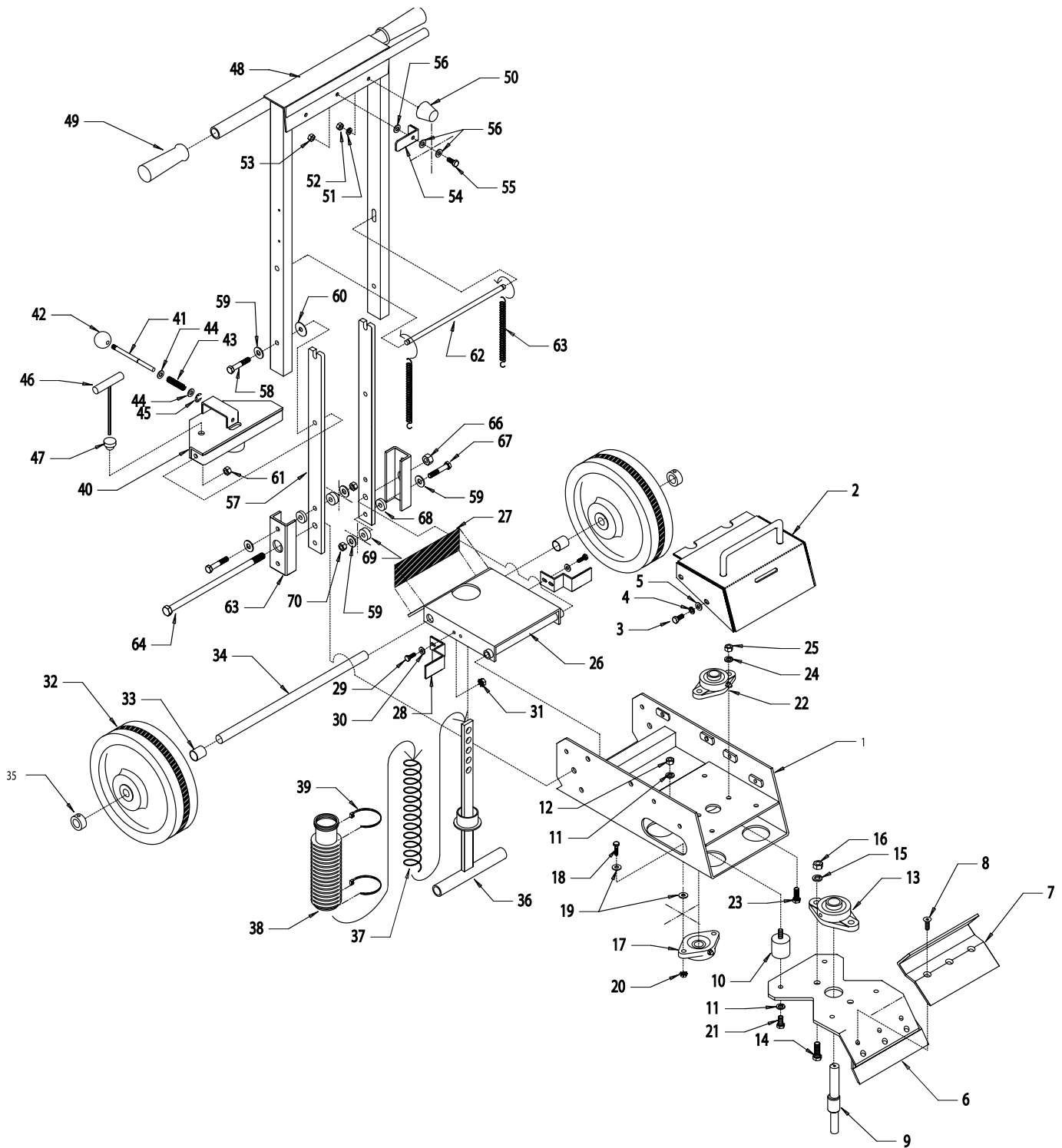

PARTS LISTING - ILLUSTRATION 1: MAIN FRAME GROUPING

ITEM #	PART #	DESCRIPTION	QTY.		ITEM #	PART #	DESCRIPTION	QTY.	
1	28101	MAIN FRAME	1		35	10428	COLLAR, LOCKING 3/4 ID.	2	
2	28102	HOOD	1		36	28106	ADJUSTMENT BAR, ANGLE	1	
3	10053	SCREW, CAP 5/16-18 x 3/4	4		37	28107	SPRING, COMP., 1.468"OD x 11"FL	1	
4	10801	WASHER, LOCK 5/16	4		38	24761	BELLOWS 1-3/4 ID x 10-1/4 LG.	1	
5	10213	WASHER, FLAT 5/16	4		39	10982	TIE, CABLE, BLACK NYLON 11-1/4	2	
6	28114	STRIKER PLATE	1		40	28108	LATCH SUPPORT	1	
7	28120	RETAINER, SCRAPER BLADE	1		41	28123	PIN, PLUNGER	1	
8	11682	SCREW, SKT. FLAT HEAD 5/16-18 x 1	3	ITEMS 8 & 46 SELECT HERE	42	10920	KNOB, BALL 1-3/8 w/ 5/16-24 THD.	1	
9	28116	CAM SHAFT, STRIKER PLATE	1		43	28124	SPRING, COMP., .484 OD x 1.88 FL	1	
10	28115	MOUNT, FLEX-BOLT SANDWICH	4		44	10213	WASHER, FLAT 5/16	2	
11	10811	WASHER, LOCK 3/8	8		45	10137	RETAINING RING, E-CLIP 5/16	1	
12	10404	NUT 3/8-16	4		46	28132	HEX KEY WRENCH 3/16 T-HANDLE	1	
13	62022	BEARING, BALL 1" 2-HOLE FLANGE	1		47	28122	RUBBER PLUG, HEX KEY WRENCH	1	
14	10003	SCREW, CAP 7/16-20 x 1-1/4	2		48	28109	HANDLE BAR	1	
15	10450	WASHER, LOCK 7/16	2		49	10608	HAND GRIP 1" MODELAT	2	
16	10481	NUT, REG. 7/16-20	2		50	10931	MOUNT, TAPERED RUBBER 5/16-18	2	
17	80009G	BEARING, BALL 5/8 2-HOLE FLANGE	1		51	10801	WASHER, LOCK 5/16	2	
18	10031	SCREW, CAP 1/4-20 x 1	2		52	10054	NUT 5/16-18	1	
19	10602	WASHER, FLAT 1/4	3		53	10807	NUT, LOCK 5/16-18	2	
20	10861	NUT, KEPS 1/4-20	2		54	28125	LATCH, HANDLE HOLD-DOWN	1	
21	10907	SCREW, CAP 3/8-16 x 3/4	4		55	10053	SCREW, CAP 5/16-18 x 3/4	1	
22	50049	BEARING, BALL 3/4" 2-HOLE FLANGE	1		56	10213	WASHER, FLAT 5/16 SAE	3	
23	10021	SCREW, CAP 3/8-24 x 1	2		57	28117	HANDLE BAR, LOWER LEG	2	
24	10811	WASHER, LOCK 3/8	2		58	10336	SCREW, CAP 3/8-24 x 2-1/4	2	
25	10014	NUT, 3/8-24	2		59	10025	WASHER, FLAT 3/8	11	
26	28103	FORK	1		60	28133	WASHER, FLAT 13/32 x 1-1/4 x .047	2	
27	28134	TREAD, ABRASIVE 2-1/4 x 7-1/2	1		61	10004	NUT, LOCK 3/8-24	2	
28	28126	WIPER, WHEEL	2		62	28118	ROD, HANDLE SPRING	1	
29	10018	SCREW, CAP 1/4-20 x 3/4	4		63	3636	SPRING, EXT. 6" L ("A" ADAPTER)	2	
30	10602	WASHER, FLAT 1/4 SAE	4		64	28110	HANDLE BAR MOUNTING BRACKET	2	
31	10861	NUT, KEPS 1/4-20	4		65	10355	SCREW, CAP 1/2-13 x 11	1	
32	28129	WHEEL, PHENOLIC 10 x 2-1/2 x 3/4 BRG.	2		66	10407	NUT, LOCK 1/2-13	1	
33	28105	WHEEL SPACER 13/16 ID x 15/16 OD x 1"L	2		67	10030	SCREW, CAP 3/8-24 x 2	4	
34	28104	AXLE SHAFT 3/4 DIA. x 17"L	1		68	56018	BUSHING, RUBBER 1"OD x 3/8" ID x 1/4 4		
						69	40329	BUSHING, RUBBER 1"OD x 3/8" ID x 3/8 4	
						70	10004	NUT, LOCK 3/8-24	4



ILLUSTRATION 2: MOTOR GROUPING

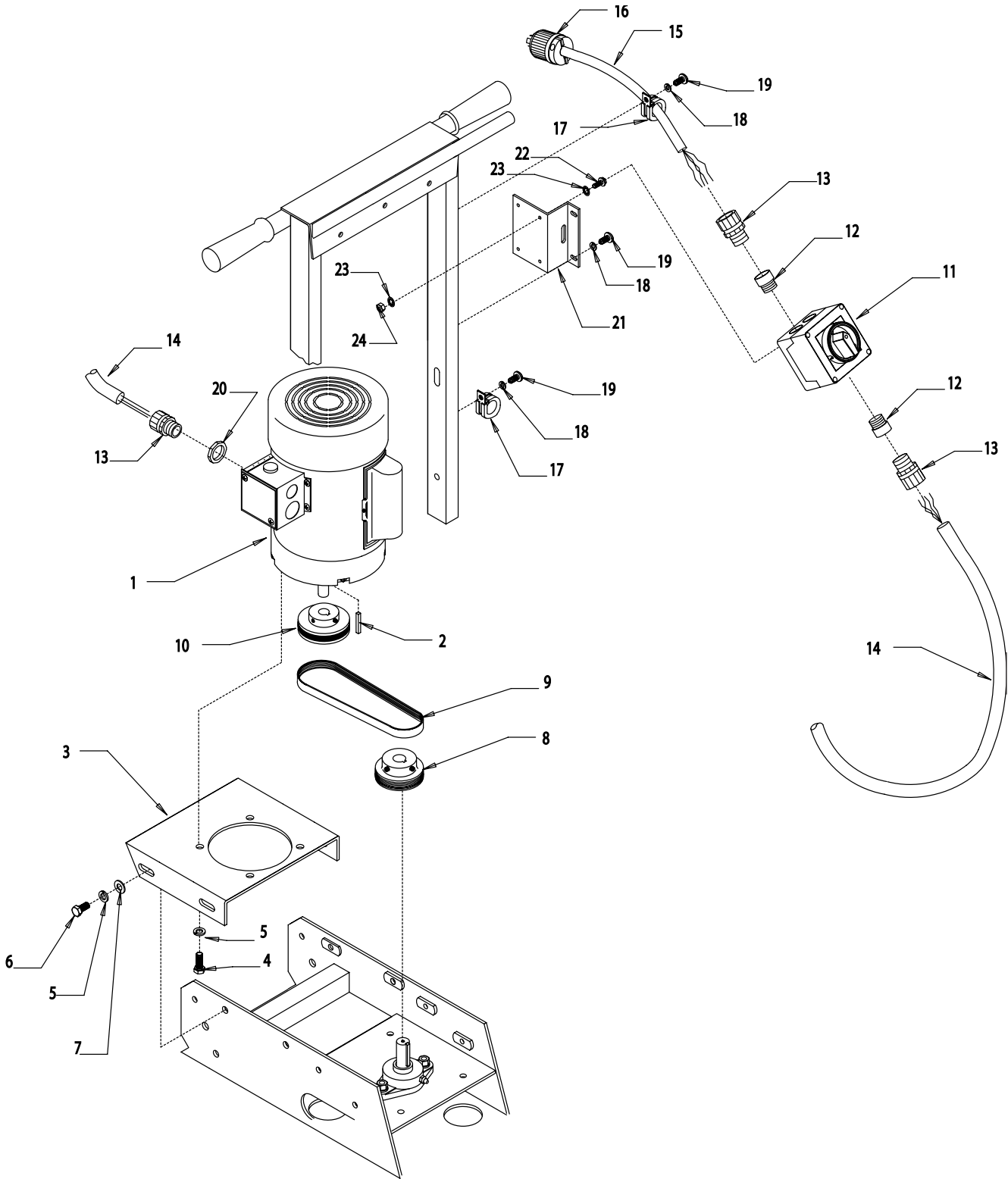

PARTS LISTING - ILLUSTRATION 2: MOTOR GROUPING			
ITEM #	PART #	DESCRIPTION	QTY.
1	16045	MOTOR,LEESON .75HP 1PH 1725RPM 115/208-230V, 10.8/5.4 FLA	1
2	~~~~~	KEY, INCL. w/ MOTOR	1
3	28111	MOUNT, MOTOR	1
4	10907	SCREW, CAP 3/8-16 x 3/4	4
5	10811	WASHER, LOCK 3/8	4
6	10907	SCREW, CAP 3/8-16 x 3/4	4
7	10025	WASHER, FLAT 3/8	4
8	28130	SHEAVE 2.80" OD x 6Gr.J x 3/4 BORE	1
9	28113	BELT 220J 6-GROOVE	1
10	28131	SHEAVE 3.0" OD x 6Gr.J x 5/8 BORE	1
11	77043	SWITCH, ROTARY CAM ON/OFF, LOVATO	1
12	~~~~~	ADAPTER (INCL. w/ SWITCH)	2
13	41130	STRAIN RELIEF 1/2 NPT x .550-.650	3
14	28135	WIRE, HARNESS 12/3 SWITCH/MOTOR	1
15	28136	WIRE HARNESS 12/3 SWITCH/PLUG	1
16	78114	PLUG, STRAIGHT 15A/125V	1
17	11565	CLAMP, LOOM 5/8 (SAE SIZE 10)	2
18	10038	WASHER, LOCK 1/4	4
19	10846	SCREW, CAP STSHW 1/4-20 x 1/2	4
20	10790	CONDUIT LOCK NUT 1/2 NP	1
21	77042	BRACKET, SWITCH BOX, LOVATO	1
22	11663	SCREW, MACHINE 8-32 x 1/2	4
23	10461	WASHER, LOCK, INT. TOOTH # 8	4
24	10462	NUT 8-32	4



LIMITED EQUIPMENT WARRANTY

Equipment Development Company, Inc. herein referred to as EDCO warrants that each new unit manufactured by EDCO to be free from defects in material and workmanship in normal use and service for a period of (1) one year (except in the case of the striker plate and flex bolt sandwich mount assembly, in which case the warranty period shall be 90 days) from date of shipment to the original buyer or equipment Rental Center owner.

EDCO will, at its option, repair or replace, at the EDCO factory or at a point designated by EDCO any part, which shall appear to the satisfaction of EDCO inspection to have been defective in material or workmanship.

This warranty, does not apply to failure occurring as a result of abuse, misuse, negligent repairs, corrosion, erosion, normal wear and tear, alterations or modifications made to the product without express written consent of EDCO: or failure to follow the recommended operating practices and maintenance procedures as provided in the products operating and maintenance manuals.

This warranty does not obligate EDCO to bear any transportation charges in connection with the replacement or repair of defective parts. This warranty does not obligate EDCO to bear any expense for travel time or of personnel in connection with any service calls.

Accessories or equipment furnished and installed on the product by EDCO but manufactured by others, including but not limited to engines, motors, electrical equipment, transmissions, etc., shall carry the accessory manufacturers' own warranty.

THIS WARRANTY IS IN LIEU OF ALL OTHER WARRANTIES, EXPRESSED OR IMPLIED, OR STATUTORY, INCLUDING ANY WARRANTIES OF MERCHANTABILITY OR OF FITNESS FOR A PARTICULAR PURPOSE.

LIABILITY LIMITATIONS

The remedies of the user set forth under provisions of warranty outlined above are the exclusive and total liability of EDCO with the respect to their sale or the equipment and service furnished hereunder, in connection with the performance or breach thereof, or from the sale, delivery, installation, repair or technical direction covered by or furnished under the sale, whether based on contract, warranty, negligence, indemnity, strict liability, or otherwise shall not exceed the purchase price of the unit of equipment upon which such liability is based.

EDCO will not in any event be liable to the user, any successors in interest or any beneficiary or assignee relating to this sale for any consequential, incidental, indirect, special or punitive damages arising out of this sale or any breach thereof, or any defects on, or failure of, or malfunction of the equipment under this sale based upon loss of use, lost profits or revenue, interest, lost goodwill, work stoppage, impairment of other goods, loss by reason of shutdown or non-operation, increased expenses of operation of the equipment, cost of purchase or replacement power of claims of users or customers of the user for service interruption whether or not such loss or damage is based on contract, warranty, negligence, indemnity, strict liability, or otherwise.

EDCO reserves the right to modify, alter and improve any part or parts without incurring any obligation to replace any part or parts previously sold without such modified, altered or improved part or parts.

No person is authorized to give any other warranty or to assume any additional obligation on EDCO's behalf unless made in writing and signed by an officer of EDCO.

Equipment Development Company, Inc.

USE ONLY GENUINE EDCO PARTS AND ACCESSORIES

For your own safety, the safety of others and the life of your machine





Parts Change Bulletin

REVISED HARDWARE AND WRENCH ON TILE SHARK™ FLOOR STRIPPERS FOR SCRAPER BLADE RETAINER AND STRIKER PLATE

The Screws that fasten the Scraper Blade Retainer to the Striker Plate have been changed from ¼-20 to 5/16-18 thread as requested. The T-Handle Hex Key Wrench was also changed from 5/32" to 3/16" to match with the Screws. Any replacement Striker Plates or Blade Retainers will be only for the 5/16-18 Screws. All units starting with Serial Number 1032 and up will have the new 5/16" Screws and the 3/16" Wrench. See the chart below for units prior to Serial Number 1032 if replacing the Screws or the Wrench only.

ILLUSTRATION 1 - SCREW AND WRENCH CHANGE			
SERIAL NUMBER 1001 – 1017, 1030,1031			
ITEM #	PART #	DESCRIPTION	QTY.
8	11677	SCREW, SKT. FLAT HD. ¼-20 X 1	3
46	28121	WRENCH, HEX KEY 5/32", T-HANDLE	1
SERIAL NUMBER 1018 – 1029, 1032 AND UP			
8	11682	SCREW, SKT. FLAT HD. 5/16-18 X 1	3
46	28132	WRENCH, HEX KEY 3/16", T-HANDLE	1

EQUIPMENT DEVELOPMENT COMPANY, INC.

100 Thomas Johnson Drive, Frederick, MD 21702-4600 USA
 Phone: 1-800-638-3326 or 301-663-1600 Fax: 1-800-437-3326 or 301-663-1607
 email: sales@edcoinc.com Website: www.edcoinc.com