

REVISED STARTING  
SERIAL # 130410266

## PARTS LIST MANUAL 48" CORE DRILL RIGS



SKU #	MODEL #	VACUUM PUMP	DRILL MOTOR	SPEED/RPM
97100EV	4820	INCLUDED	MILWAUKEE DYMO DRILL	2 SPEED
97100E	4820	NOT INCLUDED	20 AMP, 120 VOLT, 60 HZ	300/600



A Division of Equipment Development Company, Inc.

100 Thomas Johnson Drive, Frederick, MD 21702-4600 USA

Phone (301) 663-1600 • 1-800-638-3326

Fax (301) 663-1607 • 1-800-447-3326

Website: [www.edcoinc.com](http://www.edcoinc.com)

Email: [sales@edcoinc.com](mailto:sales@edcoinc.com)

Printed in USA

JWA ©2013

## READ AND UNDERSTAND THE OPERATORS INSTRUCTION MANUAL THOROUGHLY BEFORE ATTEMPTING TO OPERATE THIS EQUIPMENT.



**Death or serious injury could occur if this machine is used improperly.**



### SAFETY MESSAGES

- Safety Instructions are preceded by a graphic alert symbol of DANGER, WARNING, or CAUTION.



Indicates an imminent hazard which, if not avoided, will result in death or serious injury.



Indicates an imminent hazard which, if not avoided, can result in death or serious injury.



Indicates hazards which, if not avoided, could result in serious injury and or damage to the equipment.

### GASOLINE/PROPANE POWERED EQUIPMENT



- Engine exhaust from this product contains chemicals known to the State of California to cause cancer, birth defects or other reproductive harm.



- Gasoline is extremely flammable and poisonous. It should only be dispensed in well ventilated areas, and with a cool engine.

- Small gasoline engines produce high concentrations of carbon monoxide (CO) example: a 5 HP 4 cycle engine operation in an enclosed 100,000 cu. ft. area with only one change of air per hour is capable of providing deadly concentrations of CO in less than fifteen minutes. Five changes of air in the same area will produce noxious fumes in less than 30 minutes. Gasoline or propane powered equipment should not be used in enclosed or partially enclosed areas. Symptoms of CO poisoning include, headache, nausea, weakness, dizziness, visual problems and loss of consciousness. If symptoms occur - get into fresh air and seek medical attention immediately.

### ELECTRICAL POWERED EQUIPMENT



Extreme care must be taken when operating electric models with water present: Ensure power cord is properly grounded, is attached to a Ground-Fault-Interrupter (GFI) outlet, and is undamaged.

- Check all electrical cables - be sure connections are tight and cable is continuous and in good condition. Be sure cable is correctly rated for both the operating current and voltage of this equipment.
- Improper connection of the equipment-grounding conductor can result in a risk of electric shock. Check with qualified electrician or service person if there is any doubt as to whether the outlet is properly grounded. Adhere to **all** local codes and ordinances.
- **NOTE:** In the event of a malfunction or breakdown, grounding provides a path of least resistance for the electric current to dissipate. The motor is equipped with a grounded plug and must be connected to an outlet that is properly installed and properly grounded. **DO NOT** modify the plug provided on the motor. If the plug does not fit the outlet have a qualified electrician install the proper receptacle.
- Switch motor OFF **before** disconnecting power.

- Do not disconnect power by pulling cord. To disconnect, grasp the plug, not the cord.
- Unplug power cord at the machine when not in use and before servicing.

### GENERAL INSTRUCTIONS

- Equipment should only be operated by trained personnel in good physical condition and mental health (not fatigued). The operator and maintenance personnel must be physically able to handle the bulk weight and power of this equipment.
- This is a one person tool. Maintain a safe operating distance to other personnel. It is the **operators' responsibility** to keep other people (workers, pedestrians, bystanders, etc.) away during operation. Block off the work area in all directions with roping, safety netting, etc. for a safe distance. Failure to do so may result in others being injured by flying debris or exposing them to harmful dust and noise.
- This equipment is intended for commercial use only.
- For the operator's safety and the safety of others, always keep all guards in place during operation.
- Never let equipment run unattended.



- Personal Protection Equipment and proper safety attire must be worn when operating this machinery. The operator must wear approved safety equipment appropriate for the job such as hard hat and safety shoes when conditions require. Hearing protection **MUST** be used (operational noise levels of this equipment may exceed 85db). Eye protection **MUST** be worn at all times.



Keep body parts and loose clothing away from moving parts. Failure to do so could result in dismemberment or death.

- Do not modify the machine.
- Stop motor/engine when adjusting or servicing this equipment.



Maintain a safe operating distance from flammable materials. Sparks from the cutting-action of this machine can ignite flammable materials or vapors.

### DUST WARNING



Some dust created by power sanding, sawing, grinding, drilling, and other construction activities contains chemicals known to cause cancer, birth defects, or other reproductive harm. Some examples of these chemicals are:

- Lead from lead-based paints, and
- Crystalline silica from bricks and concrete and other masonry products.

Your risk of exposure to these chemicals varies depending on how often you do this type of work. To reduce your risk: work in a well ventilated area, use a dust control system, such as an industrial-style vacuum, and wear approved personal safety equipment, such as a dust/particle respirator designed to filter out microscopic particles.

# PARTS LIST MANUAL 48" CORE DRILL RIGS

## TABLE OF CONTENTS

<u>Section</u>	<u>Page Number</u>
Safety Messages and General Instructions . . . . .	2
How To Order Replacement Parts . . . . .	3
Illustration 1: Base and Column Grouping . . . . .	4, 5
Illustration 2: Vacuum Pump Assembly . . . . .	6, 7
Illustration 3: Carriage Assembly . . . . .	8, 9
Illustration 4: Drill Motor Grouping . . . . .	10, 11
Illustration 5: Motor Mount Kit for 14" Drill Bit . . . . .	12
Illustration 6: Motor Mount Kit for 16" Drill Bit . . . . .	13
Illustration 7: Control Box Assembly . . . . .	14
Illustration 8: Wiring Diagram for Control Box . . . . .	15
Limited Equipment Warranty of Sale - Terms & Conditions . . . . .	16 (Back Page)

<p><b>HOW TO ORDER REPLACEMENT PARTS</b></p> <ul style="list-style-type: none"> <li>❑ To insure product safety and reliability, always use genuine EDCO replacement parts when making repairs to the equipment.</li> <li>❑ When calling for parts, specify the MODEL and SERIAL number of the machine, which can be found on the NAME PLATE. Keep that information in the space provided. In addition to this information, give part number, description, and quantity as listed on the parts list to your parts representative.</li> <li>❑ Please note: Due to improvements and changes in the equipment, the illustrations shown may be different than the actual machine.</li> </ul>	<p style="text-align: center;"><b>FILL IN INFORMATION BELOW</b></p> <p>Date of Purchase _____</p> <p>Model # _____</p> <p>Serial # _____</p> <p>SKU # _____</p>
---	---



100 Thomas Johnson Drive, Frederick, MD 21702-4600 USA  
 Phone (301) 663-1600 • 1-800-638-3326  
 Fax (301) 663-1607 • 1-800-447-3326  
 Website: [www.edcoinc.com](http://www.edcoinc.com)  
 Email: [sales@edcoinc.com](mailto:sales@edcoinc.com)

ILLUSTRATION 1: BASE AND COLUMN GROUPING

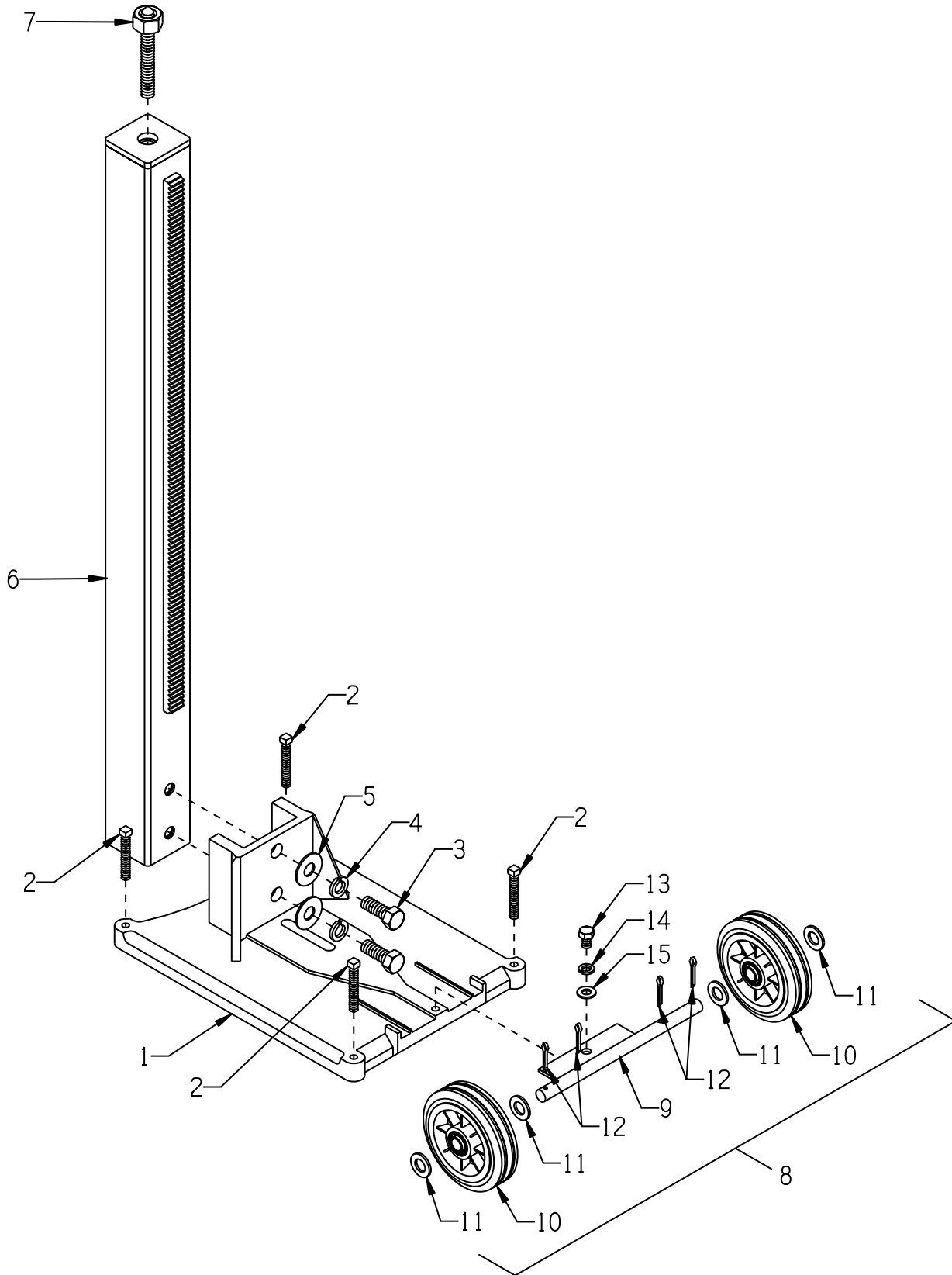

**PARTS LISTING - ILLUSTRATION 1 : BASE AND COLUMN GROUPING**

ITEM #	PART #	DESCRIPTION	QTY.
1	97003	VACUUM BASE, DRILL RIG	1
2	97017	SCREW, SET 1/2-13 X 3 SQ. HD	4
3	97020	SCREW, CAP 3/4-10 X 2	2
4	10489	WASHER, LOCK 3/4 ZINC	2
5	97021	WASHER, FLAT 3/4 USS	2
6	97044	MAST, 48" FOR LARGE DRILL RIG (COLUMN)	1
7	97050	CEILING JACK, DRILL RIG	1
8	97054K	WHEEL BASE ASSEMBLY (INCLUDES ITEMS 9 THRU 12)	1
9	97054	WHEEL BASE PLATE	1
10	80028	WHEEL 6 X 2 X 3/4" BRG.	2
11	10009	WASHER, FLAT 3/4 SAE ZINC	4
12	10306	PIN, COTTER 3/16 X 1-1/2	4
13	10914	SCREW, CAP 1/2-13 X 1	1
14	10045	WASHER, LOCK 1/2 ZINC	1
15	10312	WASHER, FLAT 1/2 SAE ZINC	1



A Division of Equipment Development Company, Inc.

100 Thomas Johnson Drive, Frederick, MD 21702-4600 USA

Phone (301) 663-1600 • 1-800-638-3326

Fax (301) 663-1607 • 1-800-447-3326

Website: [www.edcoinc.com](http://www.edcoinc.com)

Email: [sales@edcoinc.com](mailto:sales@edcoinc.com)

Printed in USA

JWA ©2013

**Page 5**

ILLUSTRATION 2 : VACUUM PUMP ASSEMBLY

PART # 97043

NOTE: THE VACUUM PUMP IS NOT INCLUDED ON ALL MODELS

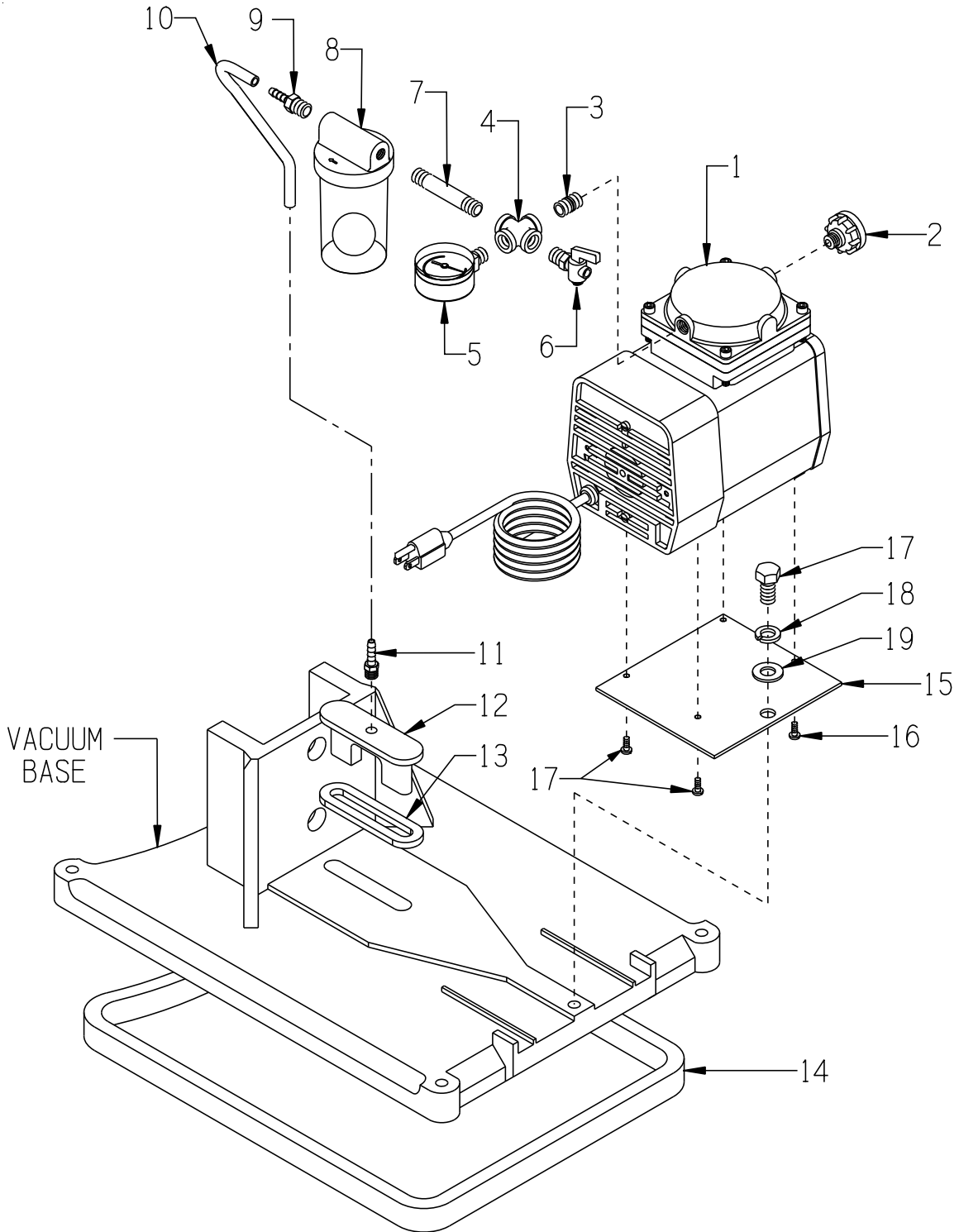

NOTE: THE VACUUM PUMP IS NOT INCLUDED ON ALL MODELS

<b>PARTS LISTING - ILLUSTRATION 2 : VACUUM PUMP ASSEMBLY</b>			
<b>ITEM #</b>	<b>PART #</b>	<b>DESCRIPTION</b>	<b>QTY.</b>
1-19	97043	VACUUM PUMP ASSEMBLY (INCLUDES ITEMS 1 THRU 19)	1
1	97027	COMPRESSOR, 115V, 4.2A, 60HZ, 60PSI	1
2	97036	MUFFLER, SCREW IN, 1/4 NPT	1
3	97032	NIPPLE, CLOSE, 1/4"NPT (BRASS)	1
4	97031	CROSS, 1/4" NPT (BRASS)	1
5	97030	GAUGE, PRESSURE/VACUUM, DRILL RIG	1
6	97029	VALVE, SHUT OFF, 1/4"NPT, 150PSI	1
7	97033	PIPE NIPPLE, 1/4NPT X 3"L (BRASS)	1
8	97028	WATER SEPARATOR	1
9	97034	BARB, 1/4HOSE X 1/4MPT (BRASS)	1
10	97055	HOSE 1/4"ID X 3/8"OD X 9"L (CLEAR)	1
11	10708	BARB, 1/4HOSE X 1/8MPT (BRASS)	1
12	97008	ANCHOR SLOT INSERT, DRILL RIG	1
13	97038	GASKET, ANCHOR SLOT	1
14	97037	GASKET, BASE	1
15	97046	MOUNT PLATE, VACUUM PUMP	1
16	10830	SCREW, MACHINE 10-32 X 1/2	4
17	10914	SCREW, CAP 1/2-13 X 1	1
18	10045	WASHER, LOCK 1/2 ZINC	1
19	10312	WASHER, FLAT 1/2 SAE ZINC	1



A Division of Equipment Development Company, Inc.

100 Thomas Johnson Drive, Frederick, MD 21702-4600 USA

Phone (301) 663-1600 • 1-800-638-3326

Fax (301) 663-1607 • 1-800-447-3326

Website: [www.edcoinc.com](http://www.edcoinc.com)

Email: [sales@edcoinc.com](mailto:sales@edcoinc.com)

Printed in USA

JWA ©2013

**Page 7**

ILLUSTRATION 3 : CARRIAGE ASSEMBLY

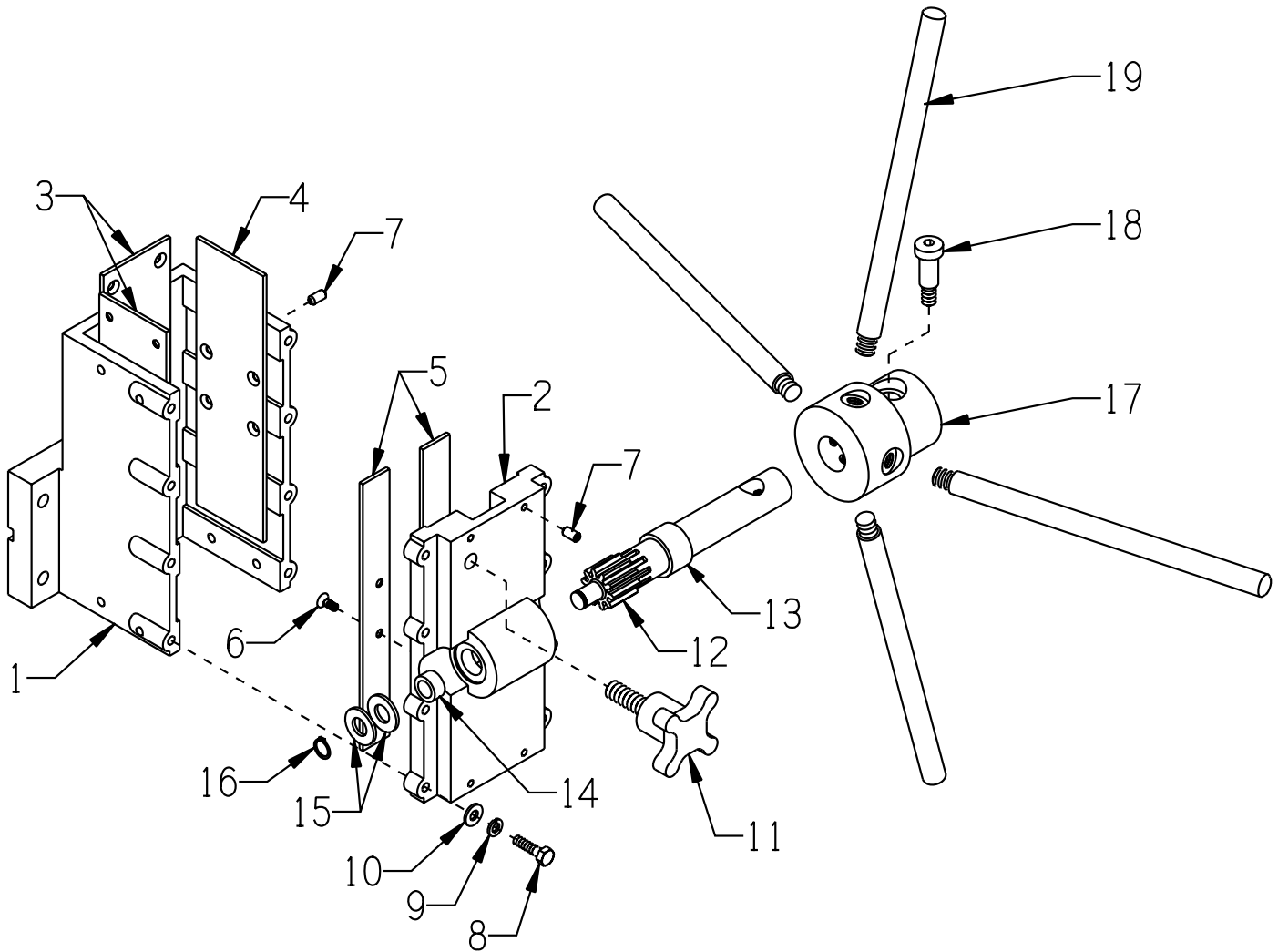



**PARTS LISTING - ILLUSTRATION 3 : CARRIAGE ASSEMBLY**

ITEM #	PART #	DESCRIPTION	QTY.
1-16	97004A	CARRIAGE ASSEMBLY LESS HANDLE (INCLUDES ITEMS 1 THRU 16)	1
1	97004	CARRIAGE	1
2	97005	CARRIAGE COVER	1
3	97047	WEAR STRIP 2.5 X 8.625 (4 HOLES IN CORNERS)	2
4	97048	WEAR STRIP 2.5 X 8.625 (4 HOLES IN CENTER)	1
5	97049	WEAR STRIP 1.0 X 8.625 (2 HOLES IN CENTER)	2
6	97016	SCREW, FLAT HD MACHINE 10-32 X 1/2 BRASS	16
7	10162	SCREW, SET 1/4-20 X 1/2"	8
8	10031	SCREW, CAP 1/4-20 X 1	8
9	10038	WASHER, LOCK 1/4 ZINC	8
10	10602	WASHER, FLAT 1/4 SAE ZINC	8
11	97025	HANDLE, ALUMINUM 1/2-13 X 1 1/2	1
12	97010	PINION GEAR	1
13	97023	SPACER, BRASS 1 1/4 OD X 1"ID X 3/4	1
14	97024	SPACER, BRASS 3/4OD X 1/2"ID X 3/8	1
15	10312	WASHER, FLAT 1/2 SAE ZINC	2
16	97014	RETAINING RING, EXT. 1/2"	1
17	97052	HANDLE YOKE	1
18	97026	SCREW, SKT.SHOULDER 5/8 X 1, 1/2-13	1
19	97045	HANDLE, 10"	4



A Division of Equipment Development Company, Inc.

100 Thomas Johnson Drive, Frederick, MD 21702-4600 USA

Phone (301) 663-1600 • 1-800-638-3326

Fax (301) 663-1607 • 1-800-447-3326

Website: [www.edcoinc.com](http://www.edcoinc.com)

Email: [sales@edcoinc.com](mailto:sales@edcoinc.com)

Printed in USA

JWA ©2013

**Page 9**

ILLUSTRATION 4 : DRILL MOTOR GROUPING

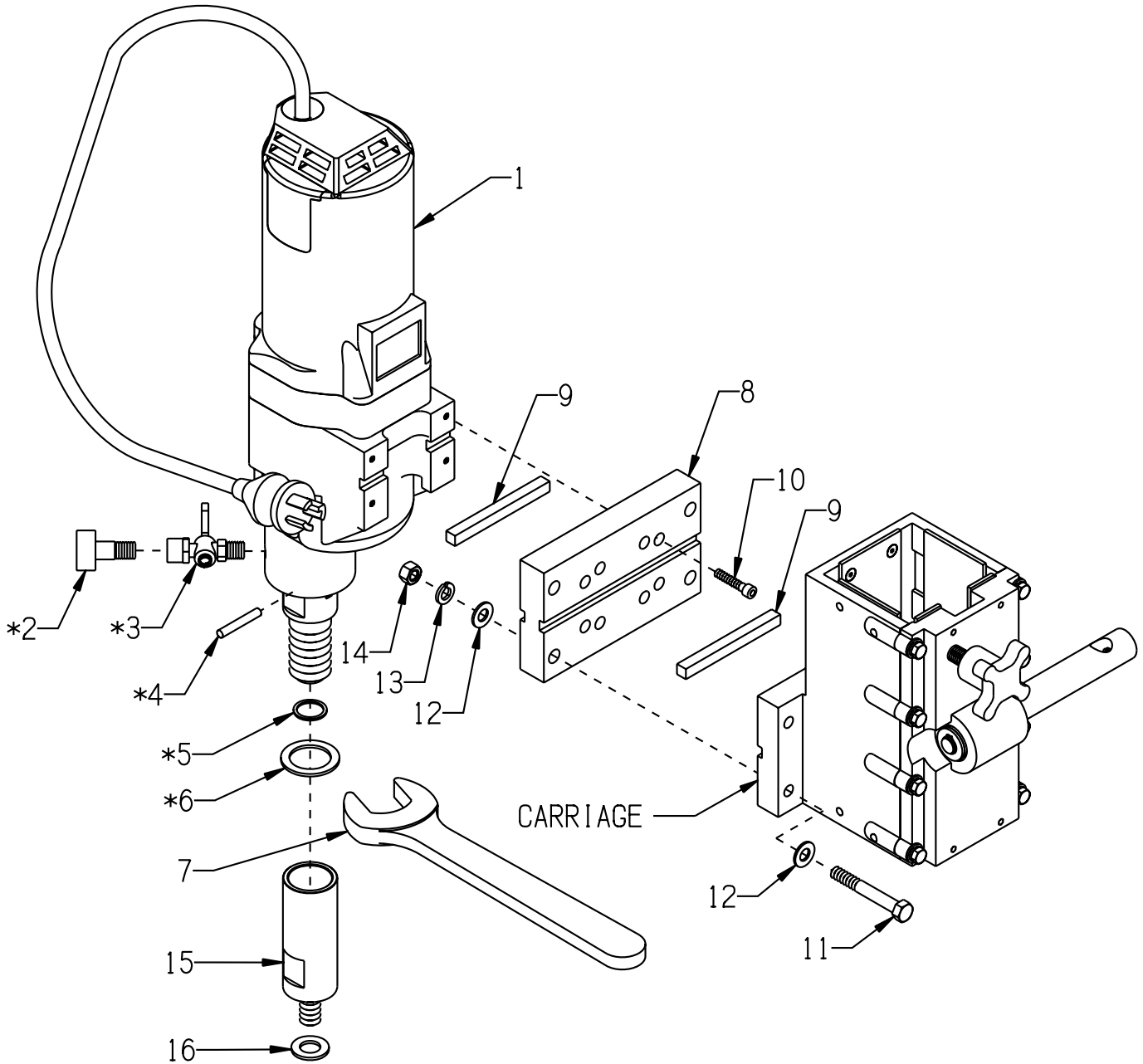

PARTS LISTING - ILLUSTRATION 4: DRILL MOTOR GROUPING			
ITEM #	PART #	DESCRIPTION	QTY.
1	97001	DRILL MOTOR (INCLUDES ITEMS ITEMS 1 THRU 7) MILWAUKEE #4079, 20 AMP, 2 SPEED, SHEAR PIN	1
*2	97065	ADAPTER 3/4SFGH X 1/4MPT	1
*3	97064	SHUT OFF VALVE 45-80-0060	1
*4	97062	PIN, SHEAR 44-60-0032	6
*5	97068	RETAINING RING 34-60-1800	1
*6	97059	WASHER, SS 1-1/4 X 1-3/4 X 3/32	2
7	97069	WRENCH 49-96-4700 (INCLUDED W/ DRILL MOTOR)	1
8	97053	MOTOR MOUNT SPACER BLOCK	1
9	97051	KEY 3/8"SQ X 4"L	2
10	97015	SCREW, SKT. HD. CAP 1/4-20 X 1-1/4	4
11	97012	SCREW, CAP 3/8-16 X 2-3/4	4
12	10025	WASHER, FLAT 3/8 SAE ZINC	8
13	10811	WASHER, LOCK 3/8 ZINC	4
14	10810	NUT, HEX LOCK 3/8-16 ZINC	4
15	97072	ADAPTER 1 1/4-7 TO 5/8-11 (OPTIONAL FOR SMALL BITS)	1
16	10073	WASHER, FLAT 5/8 SAE ZINC (OPTIONAL)	1
* THESE ITEMS ARE INCLUDED WITH THE DRILL MOTOR IN A SEPARATE ACCESSORY BAG			



A Division of Equipment Development Company, Inc.

100 Thomas Johnson Drive, Frederick, MD 21702-4600 USA

Phone (301) 663-1600 • 1-800-638-3326

Fax (301) 663-1607 • 1-800-447-3326

Website: [www.edcoinc.com](http://www.edcoinc.com)

Email: [sales@edcoinc.com](mailto:sales@edcoinc.com)

Printed in USA

JWA ©2013

Page 11

ILLUSTRATION 5: MOTOR MOUNT KIT FOR 14" DRILL BIT

OPTIONAL - PART # 97060K

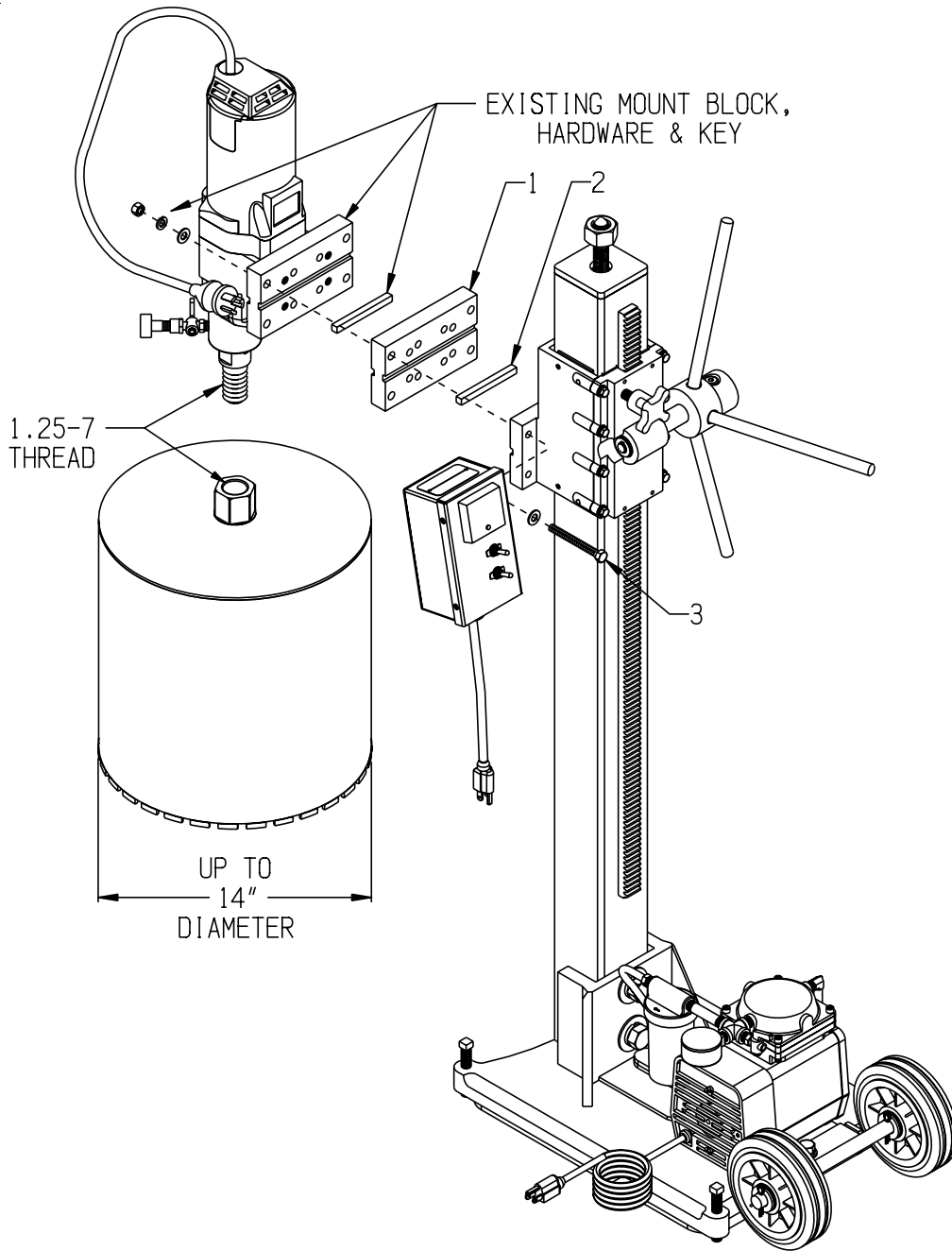

ITEM #	PART #	DESCRIPTION	QTY.
1	97053	MOTOR MOUNT SPACER BLOCK	1
2	97051	KEY 3/8"SQ X 4"L	1
3	10868	SCREW, CAP 3/8-16 X 3-1/2	4

**ILLUSTRATION 6: MOTOR MOUNT KIT FOR 16" DRILL BIT**

**OPTIONAL - PART # 97061K**

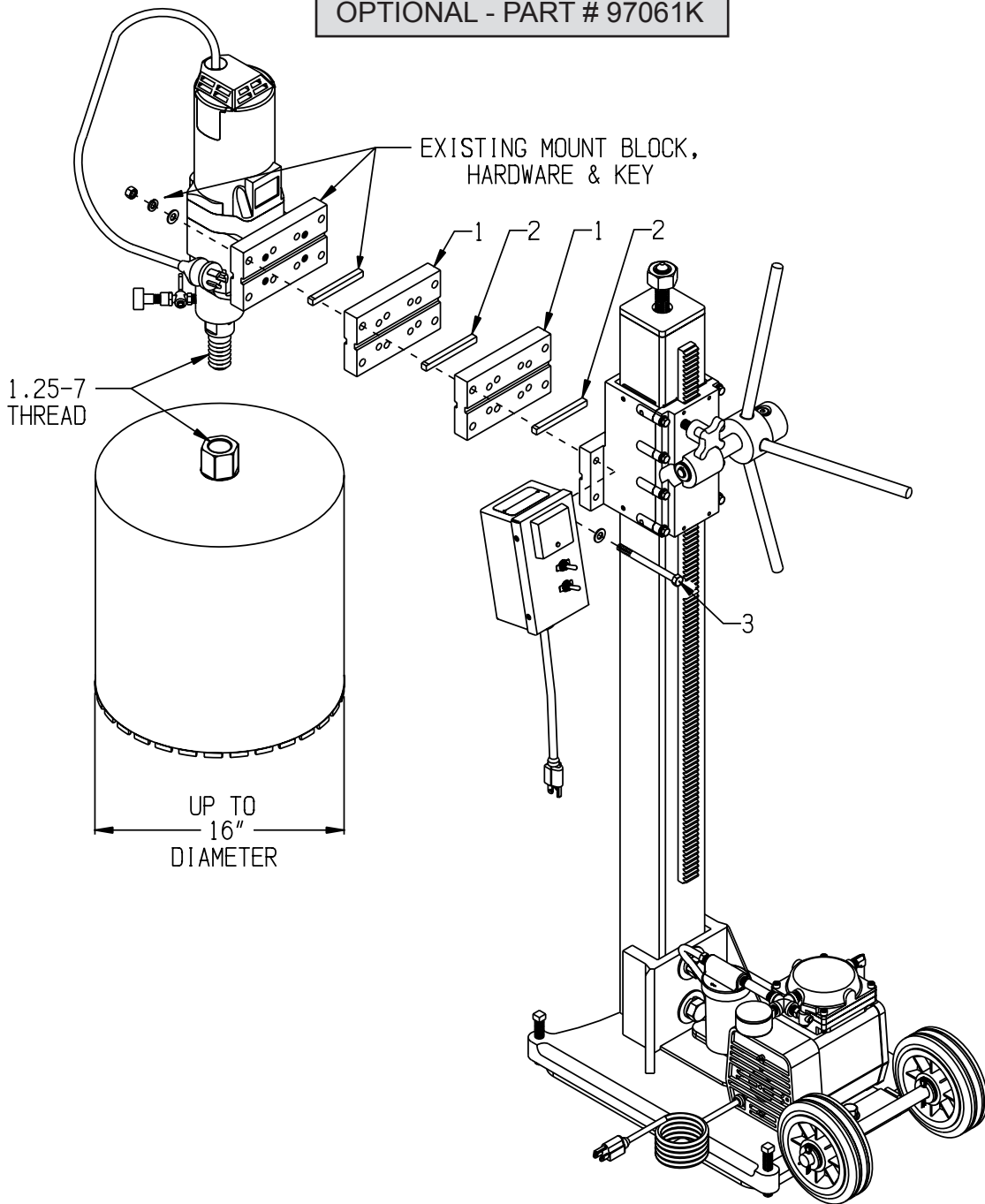

ITEM #	PART #	DESCRIPTION	QTY.
1	97053	MOTOR MOUNT SPACER BLOCK	2
2	97051	KEY 3/8"SQ X 4"L	2
3	10349	SCREW, CAP 3/8-16 X 4-1/2	4

## ILLUSTRATION 7: CONTROL BOX ASSEMBLY

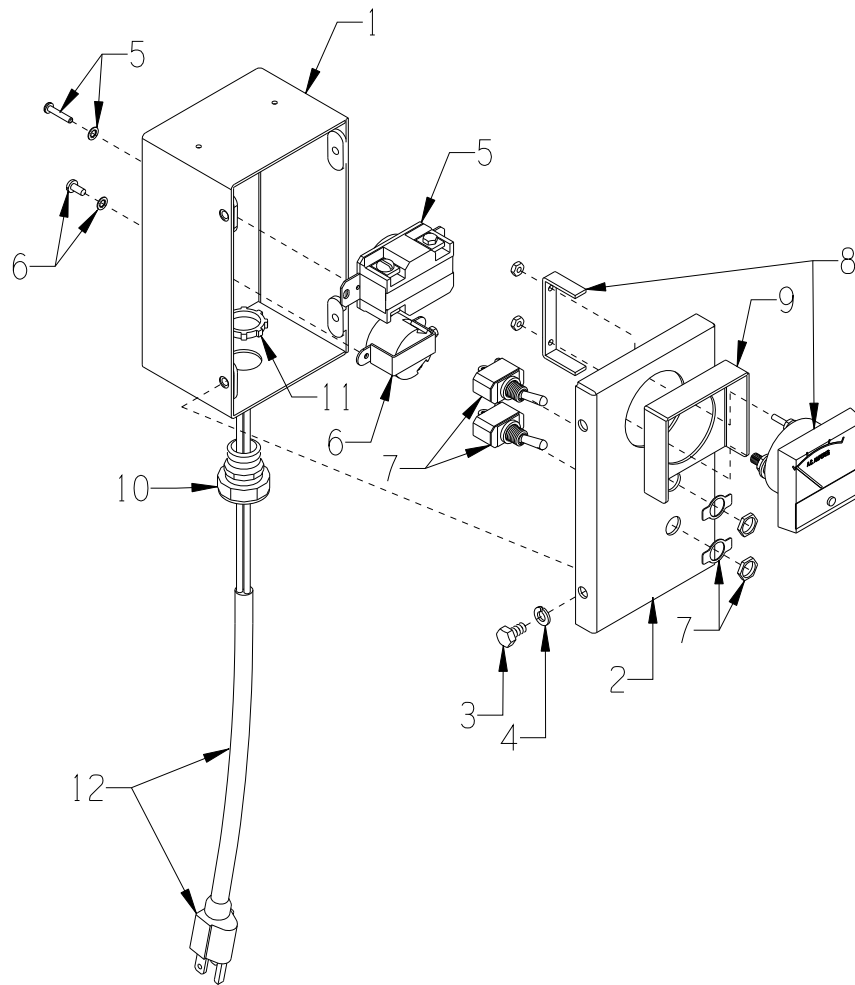

ITEM #	PART #	DESCRIPTION	QTY.
	97006A	CONTROL BOX COMPLETE (INCLUDES ITEMS 1 THRU 12)	1
1	97006	CONTROL BOX ONLY, DRILL RIG	1
2	97007	CONTROL BOX COVER, DRILL RIG	1
3	10834	SCREW, CAP 1/4-20 X 1/2 ZINC	4
4	10038	WASHER, LOCK 1/4 ZINC	4
5	16198	RECEPTACLE, LOCKING 20A-125V L520R	1
6	16199	RECEPTACLE, SINGLE 15A-125V 5258	1
7	16189	SWITCH, TOGGLE SPST 20/10A-125/250V	2
8	97009	AMMETER, 2 1/2" 0-30 AMPS A.C.	1
9	97078	AMP METER GUARD, DRILL RIG	1
10	41130	STRAIN RELIEF 1/2NPT X .550-.650"	1
11	10790	CONDUIT LOCK NUT 1/2 NP	1
12	97057	PLUG, MOLDED, 12/3 CORD	1

**ILLUSTRATION 8:  
WIRING DIAGRAM FOR CONTROL BOX**

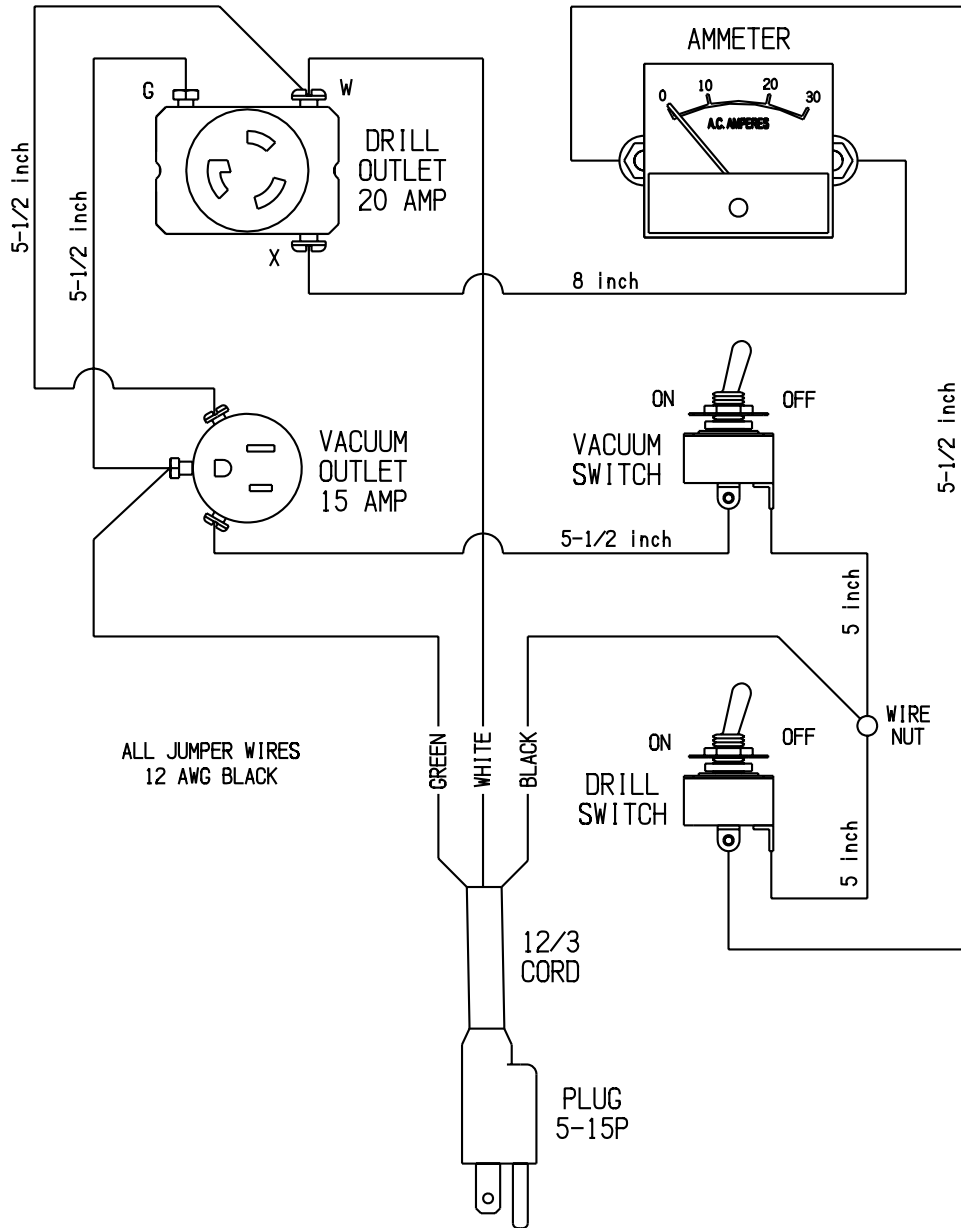

ALL JUMPER WIRES  
12 AWG BLACK

PARTS LISTING FOR WIRE AND TERMINALS REQUIRED		
PART #	DESCRIPTION	QTY.
99017	WIRE, ELEC. 12 AWG BLACK STRANDED	36" TOTAL
11715	TERM., FEM. PUSH-ON 12-10GA.	4
10967	TERM., FLANGED SPADE #10 12-10GA.	4
10968	TERM., RING 5/16 16-14GA. INSULATED	2
10966	CONNECTOR, WIRE NUT (YELLOW)	1

**LIMITED EQUIPMENT WARRANTY OF SALE – TERMS & CONDITIONS**

Equipment Development Company, Inc. herein referred to as EDCO (Seller) warrants that each new unit manufactured by EDCO to be free from defects in material and workmanship in normal use and service for a period of (1) one year (except for the cutter drum assembly on all model concrete/asphalt planes, in which case the warranty period shall be 90 days) from date of shipment to the original retail or equipment rental center owner.

Accessories or equipment furnished and installed on the product by EDCO but manufactured by others, including, but not limited to engines, motors, electrical components, transmissions etc., shall carry the accessory manufacturers own warranty.

EDCO will, at its option, repair or replace, at the EDCO factory or at a point designated by EDCO, any part which shall appear to the satisfaction of EDCO inspection to have been defective in material or workmanship.

EDCO reserves the right to modify, alter and improve any part or parts without incurring any obligation to replace any part or parts previously sold without such modified, altered or improved part or parts.

This warranty is in lieu of and excludes all other warranties, expressed, implied, statutory, or otherwise created under applicable law including, but not limited to the warranty of merchantability and the warranty of fitness for a particular purpose in no event shall seller or the manufacturer of the product be liable for special, incidental, or consequential damages, including loss of profits, whether or not caused by or resulting from the negligence of seller and/or the manufacturer of the product unless specifically provided herein. In addition, this warranty shall not apply to any products or portions thereof which have been subjected to abuse, misuse, improper installation, maintenance, or operation, electrical failure or abnormal conditions and to products which have been tampered with, altered, modified, repaired, reworked by anyone not approved by seller or used in any manner inconsistent with the provisions of the above or any instructions or specifications provided with or for the product

**FORCE MAJEURE**

Seller's obligation hereunder are subject to, and Seller shall not be held responsible for, any delay or failure to make delivery of all or any part of the Product due to labor difficulties, fires, casualties, accidents, acts of the elements, acts of God, transportation difficulties, delays by a common carrier, inability to obtain Product, materials or components or qualified labor sufficient to timely perform part of or all of the obligations contained in these terms and conditions, governmental regulations or actions, strikes, damage to or destruction in whole or part of manufacturing plant, riots, terrorist attacks or incidents, civil commotions, warlike conditions, flood, tidal waves, typhoon, hurricane, earthquake, lightning, explosion or any other causes, contingencies or circumstances within or without the United States not subject to the Seller's control which prevent or hinder the manufacture or delivery of the Products or make the fulfillment of these terms and conditions impracticable. In the event of the occurrence of any of the foregoing, at the option of Seller, Seller shall be excused from the performance under these Terms and Conditions, or the performance of the Seller shall be correspondingly extended.

This document sets forth the terms and conditions pursuant to which the purchaser ("Purchaser") will purchase and Equipment Development Co. Inc. ("Seller") will sell the products, accessories, attachments (collectively the Products) ordered by the Purchaser. These terms and conditions shall govern and apply to the sale of Seller's Products to Purchaser, regardless of any terms and conditions appearing on any purchase order or other forms submitted by Purchaser to Seller, or the inconsistency of any terms therein and herein.

**1. PRICE**

All prices set forth on any purchase order or other document are F.O.B. Sellers facility or distribution point, as may be determined by Seller (F.O.B. Point). All prices are exclusive of any and all taxes, including, but not limited to, excise, sales, use, property or transportation taxes related to the sale or use of the Products, now or hereafter imposed, together with all penalties and expenses. Purchaser shall be responsible for collecting and/or paying any and all such taxes, whether or not they are stated in any invoice for the Products. Unless otherwise specified herein, all prices are exclusive of inland transportation, freight, insurance and other costs and expenses relating to the shipment of the Products from the F.O.B. point to Purchaser's facility. Any prepayment by Seller of freight insurance and other costs shall be for the account of Purchaser and shall be repaid to Seller.

**2. PAYMENT TERMS**

Payment terms are as follows. 2% 10 days (to approved and qualified accounts). Net 30 days. This is a cash discount for invoices paid within 10 days after the invoice date, regardless of date of receipt of shipment. This is not a trade discount and will not be granted to accounts that do not adhere to stated terms.

\*All past due accounts are subject to a late payment fee of 1.5% per month or a maximum allowed by law if different, along with the expenses incidental to collection including reasonable attorney's fees and costs.

\*Seller reserves the right to hold shipments against past due accounts.

\*Seller reserves the right to alter payment terms.

**3. FREIGHT TERMS**

All shipments will be made F.O.B. shipping point as designated in these Terms and Conditions, and title shall pass at the F.O.B. point. Delivery to the initial common carrier shall constitute delivery to the Purchaser. Any claims for loss or damage during shipment are to be filed with carrier by the Purchaser. Seller will not assume responsibility for the performance of the carrier.

Back orders will be shipped in the most practical fashion with charges consistent with our freight policy established with the original order. UPS, FED EX, MAIL or shipments by other couriers are subject to the same terms and conditions as outlined in paragraph #3 "Freight Terms".

**4. DELIVERY, DAMAGES, SHORTAGES**

Seller shall use reasonable efforts to attempt to cause the Products to be delivered as provided for in these Terms & Conditions. Delivery to the initial common carrier shall constitute the delivery to the Purchaser. Seller's responsibility, in so far as transportation risks are concerned ceases upon the delivery of the Products in good condition to such carrier at the F.O.B. point and all the Products shall be shipped at the Purchaser's risk. Seller shall not be responsible or liable for any loss of income and/or profits, or incidental, special, consequential damages resulting from Seller's delayed performance in shipment and delivery.

**5. RETURN OF DEFECTIVE PRODUCTS**

Defective or failed material shall be held at the Purchaser's premises until authorization has been granted by Seller to return or dispose of Products. Products that are to be returned for final inspection must be returned Freight Prepaid in the most economical way. Credit will be issued for material found to be defective upon Seller's inspection based on prices at time of purchase.

**6. PRODUCTS ORDERED IN ERROR**

Products may be returned, provided that claim is made and Seller is notified within 7 days of receipt of Products, and the Products are in original buyer's possession not more than 30 days prior to return, subject to Seller's approval. If Products are accepted for return, they must be Freight Prepaid and buyer will be charged a minimum of 15% restocking charge, plus a charge back for outbound freight charges if the original order was shipped prepaid. Returns are not accepted for any Products that are specifically manufactured to meet the buyer's requirement of either specifications or quantity.

**AGREEMENTS**

These Terms and Conditions constitute the entire agreement between Seller and Purchaser as it relates to terms and conditions of sale, and supersedes any and all prior oral or written agreements, correspondence, quotations or understandings heretofore in force between the parties relating to the subject matter hereof. There are no agreements between Seller and Purchaser with respect to the Product herein except those specifically set forth in and made part of these terms and conditions. Any additional terms, conditions and/or prices are rejected by Seller.

These terms and conditions may be modified, cancelled or rescinded only by a written agreement of both parties executed by their duly authorized agents.

**USE ONLY GENUINE EDCO PARTS & ACCESSORIES  
For your own safety, the safety of others and the life of your machine.**

**Equipment Development Company, Inc.**

