

REVISED STARTING SERIAL# 3522

# ELECTRIC TILE SAW

## PARTS LIST MANUAL



**Model TMS-10**  
(SHOWN WITH OPTIONAL FOLDING STAND)



100 Thomas Johnson Drive, Frederick, MD 21702-4600 USA  
Phone (301) 663-1600 • 1-800-638-3326  
Fax (301) 663-1607 • 1-800-447-3326  
Website: [www.edcoinc.com](http://www.edcoinc.com) • Email: [sales@edcoinc.com](mailto:sales@edcoinc.com)

Printed in USA  
©2004

READ AND UNDERSTAND THE OPERATORS INSTRUCTION MANUAL THOROUGHLY BEFORE ATTEMPTING TO OPERATE THIS EQUIPMENT. Death or serious injury could occur if this machine is used improperly.



## SAFETY MESSAGES



The safety instructions are preceded by a graphic alert message of DANGER, WARNING, or CAUTION.



Indicates an imminent hazard which, if not avoided, will result in death or serious injury.



Indicates an imminent hazard which, if not avoided, can result in death or serious injury.



Indicates hazards which, if not avoided, could result in serious injury and or damage to the equipment.

## GASOLINE

Powered Equipment



- Do not operate gasoline powered equipment without adequate ventilation. Carbon monoxide is an invisible, odorless gas that can kill.

## ELECTRICAL

Powered Equipment



- ELECTRICAL HAZARD** - Be sure equipment is properly grounded. Failure to comply could kill or result in serious injury.



The engine exhaust from this product contains chemicals known to the State of California to cause cancer, birth defects or other reproductive harm.

## GENERAL INSTRUCTIONS



- You must read and understand the operators instruction manual and all other manuals associated with this machine. For your safety and the safety of others around you, it is extremely important to fully understand how to operate this machine in the way it was intended. Different model machines or older/newer versions of the same model may have different parts and controls that you need to understand. If instructions are not readable or available DO NOT USE this machine and contact the factory for a replacement Manual.
- You must be able to physically handle the bulk weight and power of this machine. If not properly controlled this machine can cause death or serious injury.
- Do not operate this machine in an impaired mental state. You must be able to exercise good judgement and reactions to maintain a safe working environment.
- This is a "one person" machine which means only one operator can be operating the machine at any one time. For the safety of others, maintain a safe operating distance to other personnel. Your work area should be defined and appropriately marked so bystanders and coworkers do not stand or walk near this machine and end up seriously injured by flying debris or exposing them to harmful noise or dust.
- This equipment is for Commercial use. Although this is a "one person" machine your work team should understand how to shut this machine off and quickly get medical help if an accident strikes the operator.
- Keep all guards in place during operation. The guards are to provide protection from inadvertent contact with dangerous moving parts, pinch points, or hot surfaces.
- Wear appropriate Personal Protective Equipment (PPE) including safety glasses, safety boots, work gloves, respiratory protection, hearing protection, and head protection. Do not wear loose clothing that can get tangled in moving parts. Failure to do so could result in dismemberment or death. **Wear an approved respirator when removing hazardous materials or when grinding/cutting dry materials. Some dust particles such as concrete dust can contain silicate particles which can cause silicosis (a very serious lung disease). Contact NIOSH or OSHA for further details. When wet grinding/cutting, avoid contact with the concrete/asphalt slurry which can cause serious skin irritations.**
- You must maintain this machine per the maintenance schedule in the operator manual. Remember before adjusting, servicing, or fueling this machine, disconnect the source of power to the machine by disconnecting the spark plug (Gas models), or by unplugging the electrical power cord (electric models) or air hose (Pneumatic models) AT THE MACHINE so you can assure yourself it remains unplugged while you are working on it. Do not modify this machine. Use only genuine EDCO parts and accessories. Repairs and service should be performed by approved EDCO dealers or authorized technicians.
- You should look carefully around the area before you begin work so you can identify potential hazards such as deck inserts, pipes, columns, openings, electrical cords or outlets, or any other objects protruding from the slab surface.
- This machine has no brain so you must use your own. There is no substitute for safety. The safety decals on the machine are to serve as a reminder for information you must already know before you begin using this machine. Take a moment to reread the safety decals each time you use the machine. If your machine is missing any decals, contact the factory for a replacement (EDCO 1-800-638-3326).

# PARTS LIST MANUAL

## EDCO MODEL TMS-10

Section	Page Number
Safety Messages / General Instructions . . . . .	2
How To Order Replacement Parts . . . . .	3
Illustration 1: Main Grouping . . . . .	4,5
Illustration 2: Rolling Table Assembly Grouping . . . . .	6
Illustration 3: Arbor Assembly Grouping . . . . .	7
Illustration 4: Motor & Belt Drive Grouping . . . . .	7
Limited Equipment Warranty . . . . .	back cover

TMS-10 TILE SAWS		
PART NO.	MODEL	MOTOR OPTION
24100	TMS10-1L	LEESON 1.0 HP, 1 PHASE, 60 HZ, 115V
24200	TMS10-1.5L	LEESON 1.5 HP, 1 PHASE, 60 HZ, 115V

<p><b>HOW TO ORDER REPLACEMENT PARTS</b></p> <p><input type="checkbox"/> To insure product safety and reliability, always use genuine EDCO replacement parts when making repairs to the equipment.</p> <p><input type="checkbox"/> When calling for parts, specify the MODEL and SERIAL NUMBER of the machine which can be found on the NAME PLATE. Keep that information in the space provided. In addition to this information, give part number, description and quantity as listed on the parts list to your parts representative.</p> <p><input type="checkbox"/> Please note: Due to improvements and changes in the equipment, the illustrations shown may be different than the actual machine.</p>	<p><b>FILL IN INFORMATION BELOW</b></p> <p>Date of Purchase _____</p> <p>Name of Machine _____</p> <p>Model # _____</p> <p>Serial # _____</p> <p>Belt Size(s) _____</p> <p>Toll Free: 1-800-638-3326  FAX: 1-800-447-3326  email: sales@edcoinc.com  www.edcoinc.com</p>
---	--



**ILLUSTRATION 1 : MAIN GROUPING**

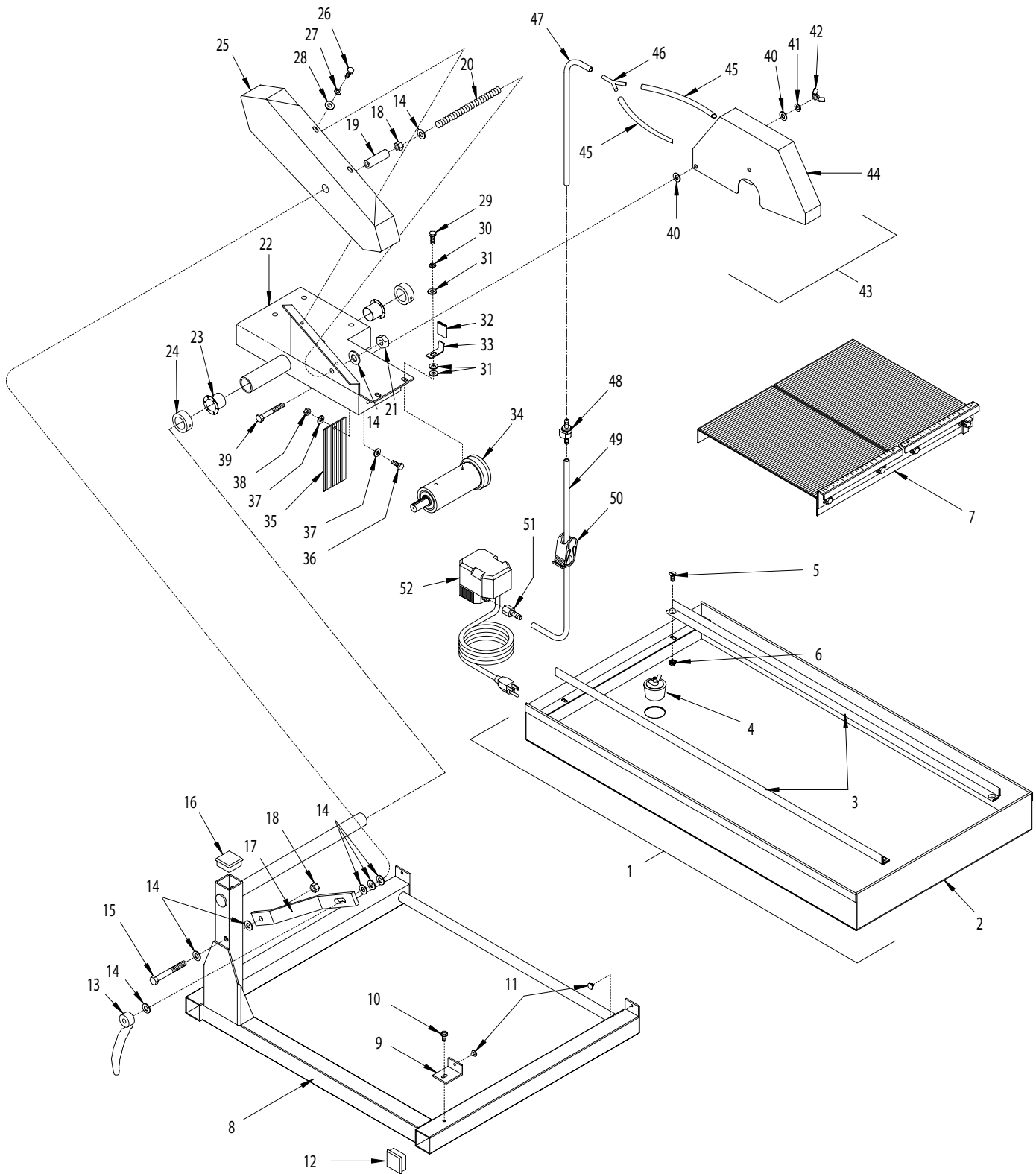

ARBOR HEIGHT LOCKING BAR ASSEMBLY HAS CHANGED - CLICK HERE FOR CHANGES

PARTS LISTING - ILLUSTRATION 1 : MAIN GROUPING							
ITEM#	PART#	DESCRIPTION	QTY.	ITEM#	PART#	DESCRIPTION	QTY.
1	42101A	PAN ASSY. W/ RAILS & STOPPER (INCLUDES ITEMS 2-6)	1	27	10038	WASHER, LOCK 1/4	2
2	42101	PAN	1	28	10602	WASHER, FLAT 1/4	2
3	42102B	TRACK RAIL 33-3/4"L	2	29	10834	SCREW, CAP 1/4-20 x 1/2	3
4	40378	STOPPER ASSEMBLY 1-1/2"	1		10018	SCREW, CAP 1/4-20 x 3/4	1
5	11540	SCREW, FLAT HEAD SLOTTED 1/4-20 x 5/8	4	30	10038	WASHER, LOCK 1/4	4
6	10861	NUT, KEPS 1/4-20	4	31	10602	WASHER, FLAT 1/4	4
7	42170	TABLE COMPLETE, ROLLING (REFER TO ILLUS. 2 FOR BREAKDOWN)	1	32	42144	COVER, VIBRATION	1
8	42107	BASE AND POST ASSEMBLY	1	33	42128	BRACKET, BLADE GUARD RETAINER	1
9	42126	BRACKET, NYLON RIVET	2	34	42114T	ARBOR ASSY. COMPLETE (REFER TO ILLUS. 3 FOR BREAKDOWN)	1
10	10846	SCREW, CAP STSHW 1/4-20 x 1/2	2	35	42161	FLAP, SPLASH 2-1/2x5-1/2	1
11	42127	RIVET, NYLON PUSH-IN PANEL	4	36	10018	SCREW, CAP 1/4-20 x 3/4	1
12	42123	PLUG, SQ. TUBE 1-1/2 x 14 GA., BLK.	2	37	10602	WASHER, FLAT 1/4	2
13	40044	NUT, TAIL HANDLE 3/8-16	1	38	10861	NUT, KEPS 1/4-20	1
14	10025	WASHER, FLAT 3/8 (*SHIM AS REQ'D TO ALIGN DECK PROPERLY)	*	39	10341	SCREW, CAP 5/16-18 x 2-1/4	1
15	<del>10030</del>	SCREW, CAP <del>3/8-24x2</del>	1	40	10213	WASHER, FLAT 5/16	2
16	42148	PLUG, SQ. TUBE 1-1/2 x 11 GA., BLK.	1	41	10801	WASHER, LOCK 5/16	1
17	42162	LOCKING BAR, ARBOR HEIGHT	1	42	10902	NUT, WING 5/16-18	1
18	10004	NUT, LOCK 3/8-24	2	43	42113T	GUARD SUBASSEMBLY, BLADE (INCLUDES ITEMS 45-51)	1
19	42163	SPACER, ARBOR HEIGHT LOCKING BAR	1	44	42113	GUARD, BLADE 10"	1
20	42164	ALLTHREAD ROD 3/8-16 X <del>4-1/4</del> 5	1	45	42141	HOSE 1/4"ID x 8"L	2
21	10156	NUT, HEX NYLON LOCK 3/8-16	1	46	99323	BARBED FITTING, "Y" 1/4"HOSE	1
22	42108N	DECK, MOTOR & ARBOR	1	47	42142	HOSE 1/4"ID X 12"L	1
23	41123	BEARING, SLEEVE 1"ID NYLON FLANGED	2	48	42134	COUPLING, QUICK-DISCONNECT 1/4"	1
24	10427	COLLAR, LOCKING 1"ID	2	49	42143	HOSE 1/4"ID x 18"L	1
25	42112	COVER, BELT	1	50	42131	CLAMP, TUBE, FLOW CONTROL 3/4"	1
26	10834	SCREW, CAP 1/4-20 x 1/2	2	51	40415	BARB, 1/4HOSE x 1/4FPT	1
				52	40017	PUMP, WATER, 115VAC, SUBMERSIBLE	1



**ILLUSTRATION 2 : ROLLING TABLE ASSEMBLY GROUPING**

**ITEM # 6 REVISED APRIL 2007  
NEW PART NUMBERS:  
42221 - RUBBER PAD 12x8x3/16  
42222 - RUBBER PAD 12x7-1/2x3/16**

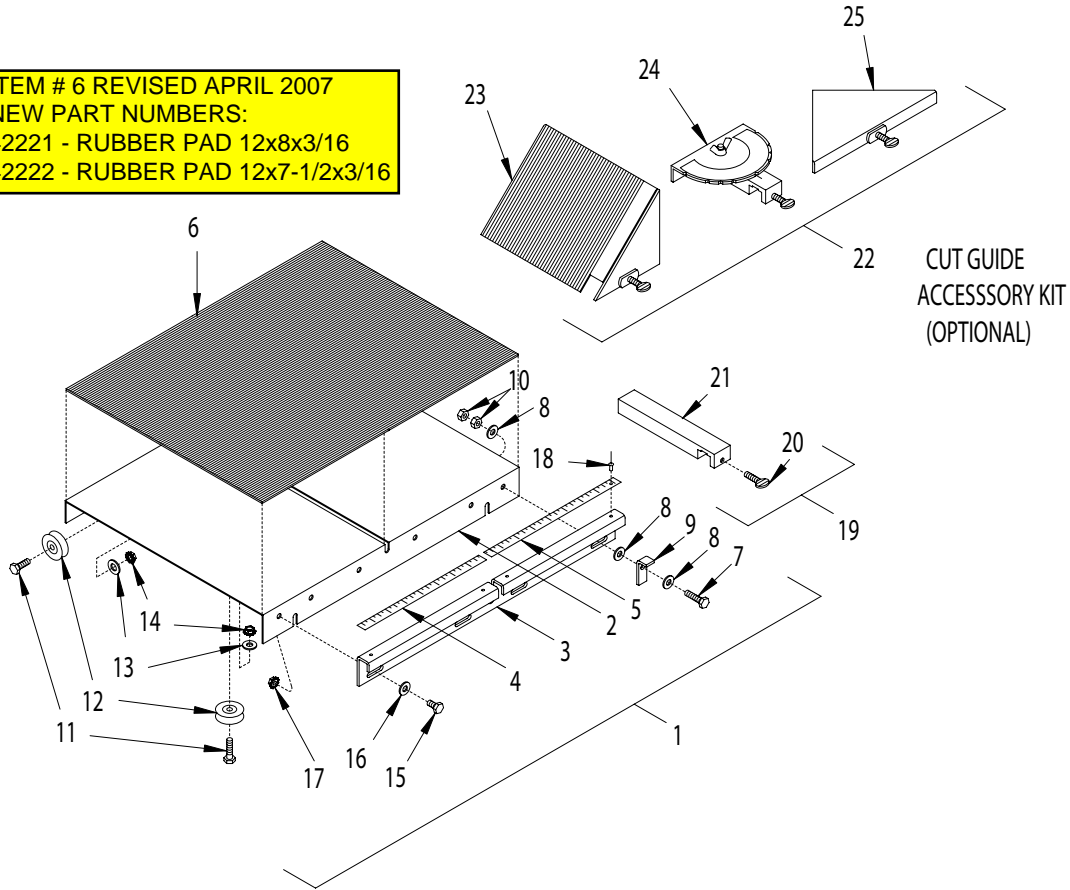

ITEM#	PART#	DESCRIPTION	QTY.
1	42170	TABLE COMPLETE, ROLLING (INCLUDES ITEMS 2-18)	1
2	42171	TABLE, ROLLING	1
3	42172	TABLE FRONT PANEL, ROLLING	1
4	42137	RULE, ADHESIVE-BACKED, 1-7, R-L	1
5	42136	RULE, ADHESIVE-BACKED, 1-8, L-R	1
6	42175	RUBBER PAD 12-1/4 X 17 X 1/8	1
7	10018	SCREW, CAP 1/4-20x3/4	1
8	10602	WASHER, FLAT 1/4	3
9	42106	LATCH, ROLLING TABLE	1
10	10015	NUT, LOCK 1/4-20	2
11	10031	SCREW, CAP 1/4-20x1	6
12	14082	PULLEY BEARING 1-1/4DIA.x1/4BORE	6
13	10602	WASHER, FLAT 1/4	6
14	10861	NUT, KEPS 1/4-20	6
15	10834	SCREW, CAP 1/4-20x1/2	3
16	10602	WASHER, FLAT 1/4	3
17	10861	NUT, KEPS 1/4-20	3
18	11571	RIVET, BLIND 1/8 X .640"L X .250"HD	4
19	42160	GUIDE ASSY., STRAIGHT CUT	1
20	42133	SCREW, THUMB, SPADE HEAD 1/4-20 X 3/4	1
21	42132	GUIDE ONLY, STRAIGHT CUT	1
22	42149	ACCESSORY PACKAGE (INCLUDES ITEMS 22-24)	1
23	42155	GUIDE ASSY., 45 DEG. MITER	1
24	42150	GUIDE ASSY., ADJ. PROTRACTOR	1
25	42153	GUIDE ASSY., DUAL 45D ANGLE	1

**ILLUSTRATION 3 : ARBOR ASSEMBLY GROUPING**

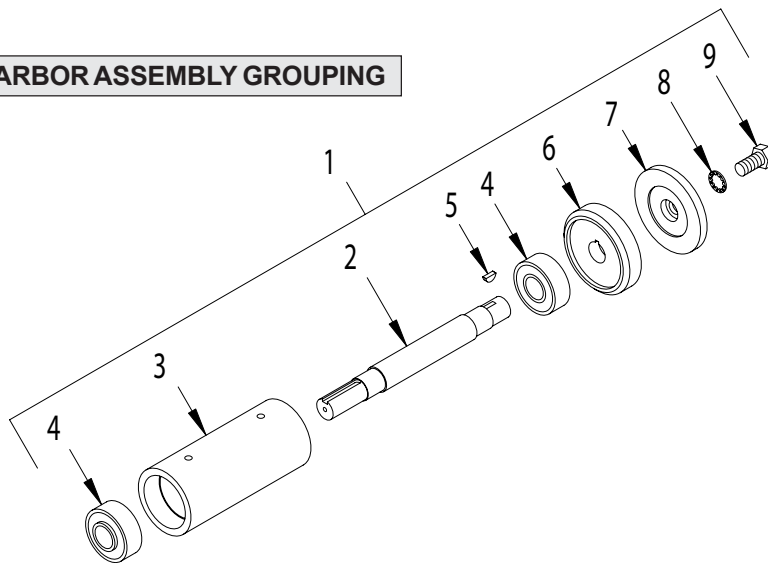

ITEM#	PART#	DESCRIPTION	QTY.	ITEM#	PART#	DESCRIPTION	QTY.
1	42114T	ARBORASSEMBLY COMPLETE (INCLUDES ITEMS 2-9)	1	5	40036	KEY, WOODRUFF 1/8x3/8 (#403)	1
2	42115	ARBOR SHAFT 6-3/4"L	1	6	42117	ARBOR BACKING PLATE 2-1/2"	1
3	42116	ARBOR HOUSING	1	7	42118	ARBOR BLADE CAP 2-1/2"	1
4	42119	BEARING, RADIAL BALL 17x40x.563	2	8	10453	WASHER, LOCK, INT. TOOTH 3/8"	1
				9	10021	SCREW, CAP 3/8-24x1	1

**ILLUSTRATION 4 : MOTOR & BELT DRIVE GROUPING**

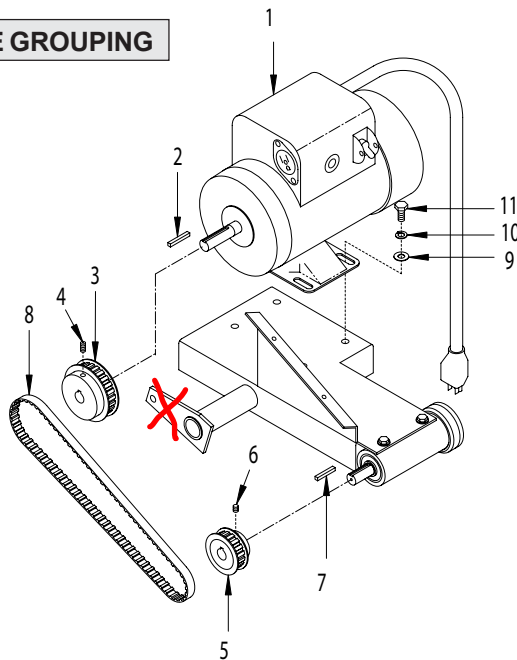

ITEM#	PART#	DESCRIPTION	QTY.	ITEM#	PART#	DESCRIPTION	QTY.
1	MOTOR, LEESON		1	6	10139	SCREW, SET 1/4-20x5/16	1
	16031	1HP-1PHASE-60HZ-1650RPM		7	10060	KEY 3/16 SQ.x1-1/4	1
	16036	1.5HP-1PHASE-60HZ-1650RPM		8	42124	BELT, TIMING 300L050	1
2	-----	KEY 3/16SQ.x1-3/8 (INCLUDED W/ MOTOR)	1	9	10213	WASHER, FLAT 5/16	4
3	42120	PULLEY, TIMING, 24L050x5/8" BORE	1	10	10801	WASHER, LOCK 5/16	4
4	10162	SCREW, SET 1/4-20x1/2	1	11	10053	SCREW, CAP 5/16-18x3/4	4
5	42121	PULLEY, TIMING, 17L050 X 5/8"BORE	1				



100 Thomas Johnson Drive, Frederick, MD 21702-4600 USA  
 Phone (301) 663-1600 • 1-800-638-3326  
 Fax (301) 663-1607 • 1-800-447-3326  
 Website: www.edcoinc.com • Email: sales@edcoinc.com

Printed in USA  
 ©2004



# LIMITED EQUIPMENT WARRANTY

Equipment Development Company, Inc. herein referred to as EDCO warrants that each new unit manufactured by EDCO to be free from defects in material and workmanship in normal use and service for a period of (1) one year (except in the case of the cutter drum assembly on all model concrete asphalt planes, in which case the warranty period shall be 90 days) from date of shipment to the original retail or equipment rental center owner.

EDCO will, at its option, repair or replace, at the EDCO factory or at a point designated by EDCO any part, which shall appear to the satisfaction of EDCO inspection to have been defective in material or workmanship.

This warranty, does not apply to failure occurring as a result of abuse, misuse, negligent repairs, corrosion, erosion, normal wear and tear, alterations or modifications made to the product without express written consent of EDCO: or failure to follow the recommended operating practices and maintenance procedures as provided in the products operating and maintenance manuals.

This warranty does not obligate EDCO to bear any transportation charges in connection with the replacement or repair of defective parts. This warranty does not obligate EDCO to bear any expense for travel time or of personnel in connection with any service calls.

Accessories or equipment furnished and installed on the product by EDCO but manufactured by others, including but not limited to engines, motors, electrical equipment, transmissions, etc., shall carry the accessory manufacturers' own warranty.

THIS WARRANTY IS IN LIEU OF ALL OTHER WARRANTIES, EXPRESSED OR IMPLIED, OR STATUTORY, INCLUDING ANY WARRANTIES OF MERCHANTABILITY OR OF FITNESS FOR A PARTICULAR PURPOSE.

## LIABILITY LIMITATIONS

The remedies of the user set forth under provisions of warranty outlined above are the exclusive and total liability of EDCO with the respect to their sale or the equipment and service furnished hereunder, in connection with the performance or breach thereof, or from the sale, delivery, installation, repair or technical direction covered by or furnished under the sale, whether based on contract, warranty, negligence, indemnity, strict liability, or otherwise shall not exceed the purchase price of the unit of equipment upon which such liability is based.

EDCO will not in any event be liable to the user, any successors in interest or any beneficiary or assignee relating to this sale for any consequential, incidental, indirect, special or punitive damages arising out of this sale or any breach thereof, or any defects on, or failure of, or malfunction of the equipment under this sale based upon loss of use, lost profits or revenue, interest, lost goodwill, work stoppage, impairment of other goods, loss by reason of shutdown or non-operation, increased expenses of operation of the equipment, cost of purchase or replacement power of claims of users or customers of the user for service interruption whether or not such loss or damage is based on contract, warranty, negligence, indemnity, strict liability, or otherwise.

EDCO reserves the right to modify, alter and improve any part or parts without incurring any obligation to replace any part or parts previously sold without such modified, altered or improved part or parts.

No person is authorized to give any other warranty or to assume any additional obligation on EDCO's behalf unless made in writing and signed by an officer of EDCO.

Equipment Development Company, Inc.

## USE ONLY GENUINE EDCO PARTS AND ACCESSORIES

For your own safety, the safety of others and the life of your machine





# MODEL TMS-10

## REVISED ARBOR HEIGHT LOCKING BAR ASSEMBLY

REV. STARTING SERIAL # 3527

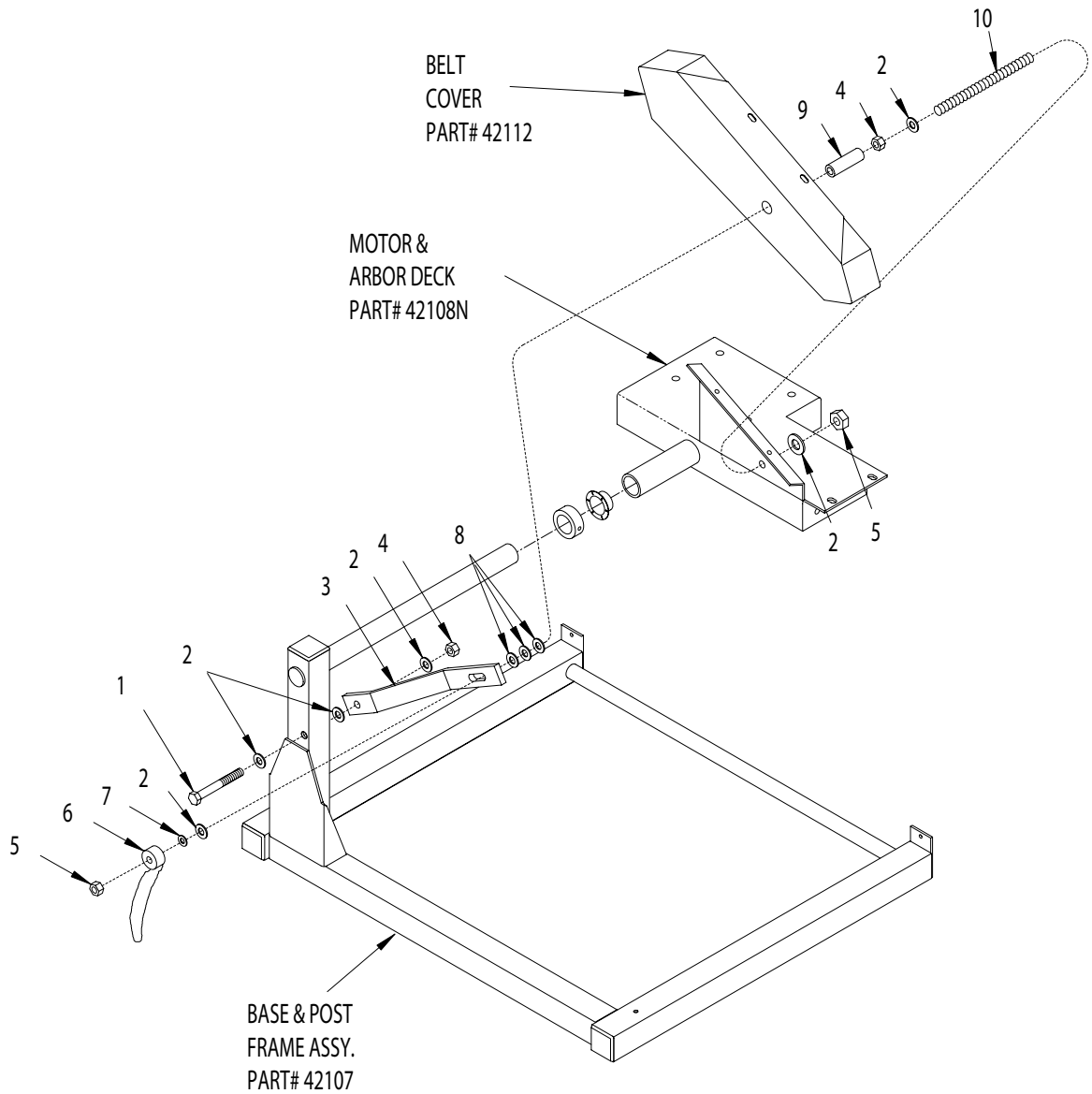

ITEM#	PART#	DESCRIPTION	QTY.
1	10393	SCREW, CAP 3/8-24 X 2-1/2	1
2	10025	WASHER, FLAT 3/8	6
3	42162	LOCKING BAR, ARBOR HEIGHT	1
4	10004	NUT, LOCK 3/8-24	2
5	10156	NUT, HEX NYLON LOCK 3/8-16	2
6	40044	NUT, TAIL HANDLE 3/8-16	1
7	10453	WASHER, LOCK, INT. TOOTH 3/8"	3
8	10025	WASHER, FLAT 3/8 (*SHIM AS REQ'D TO ALIGN DECK PROPERLY)	*
9	42163	SPACER, ARBOR HEIGHT LOCKING BAR	1
10	42164	ROD, ALLTHREAD 3/8-16 X 5	1



100 Thomas Johnson Drive, Frederick, MD 21702-4600 USA  
 Phone (301) 663-1600 • 1-800-638-3326  
 Fax (301) 663-1607 • 1-800-447-3326  
 Website: [www.edcoinc.com](http://www.edcoinc.com) • Email: [sales@edcoinc.com](mailto:sales@edcoinc.com)

Printed in USA  
 ©2004

**MODEL TMS-10  
CART ADAPTER BRACKET KIT  
PART NO. 24656**

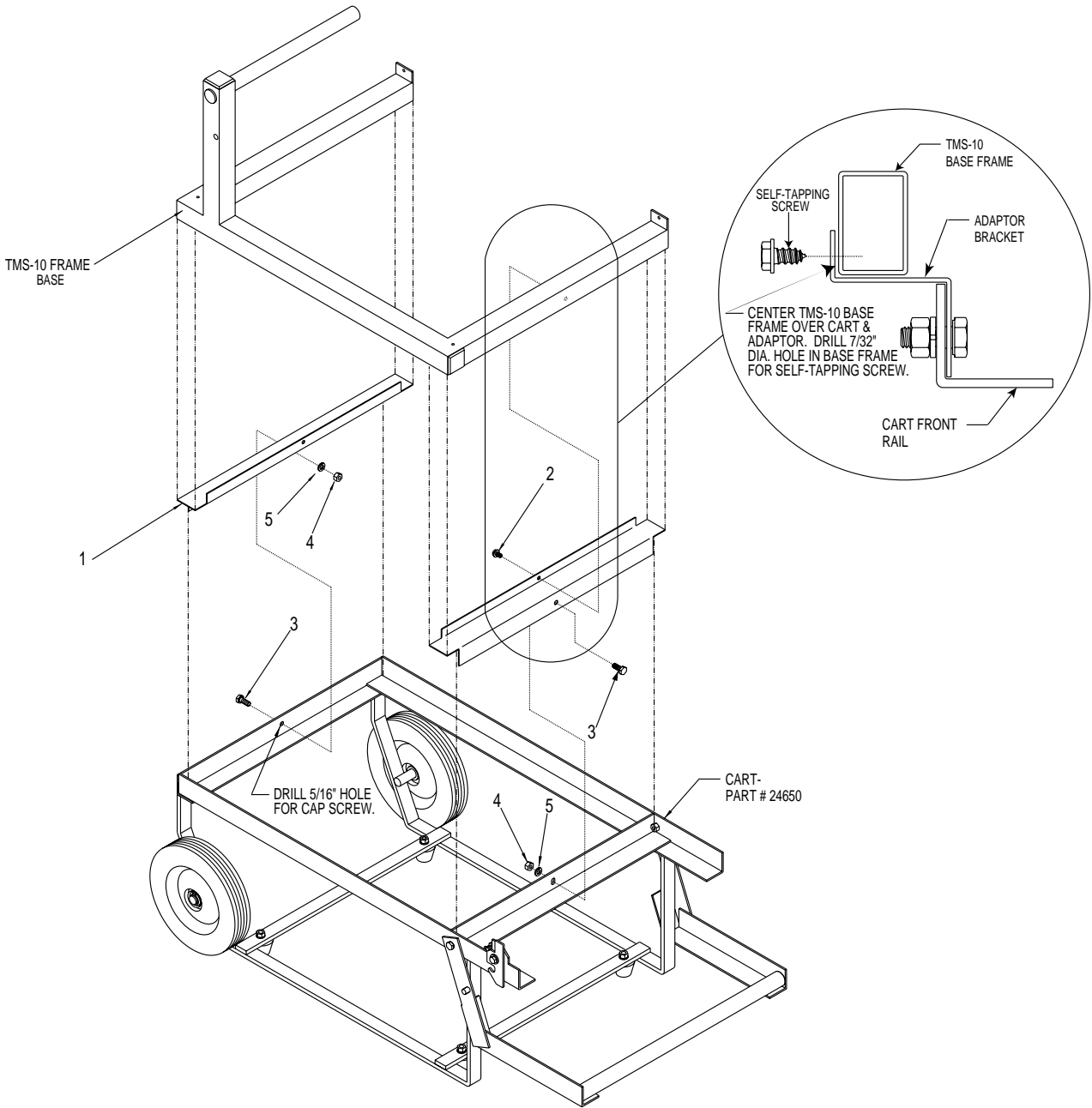

ITEM#	PART#	DESCRIPTION	QTY.
1	24655	BRACKET, ADAPTER	2
2	10846	SCREW, SELF-TAP HEX WASHER 1/4-20 x 1/2	2
3	10053	SCREW, CAP 5/16-18 x 3/4	2
4	10054	NUT 5/16-18	2
5	10801	WASHER, LOCK 5/16	2



100 Thomas Johnson Drive, Frederick, MD 21702-4600 USA  
 Phone (301) 663-1600 • 1-800-638-3326  
 Fax (301) 663-1607 • 1-800-447-3326  
 Website: www.edcoinc.com • Email: sales@edcoinc.com

Printed in USA  
 ©2000